



---

# **EZ-USB FX2**

## **Technical Reference**

### **Manual**

Cypress Semiconductor  
Interface Products Division  
15050 Avenue of Science - Suite 200  
San Diego, CA 92128



## Cypress Disclaimer Agreement

The information in this document is subject to change without notice and should not be construed as a commitment by Cypress Semiconductor Corporation Incorporated. While reasonable precautions have been taken, Cypress Semiconductor Corporation assumes no responsibility for any errors that may appear in this document.

No part of this document may be copied or reproduced in any form or by any means without the prior written consent of Cypress Semiconductor Corporation.

Cypress Semiconductor products are not designed, intended, or authorized for use as components in systems intended for surgical implant into the body, or other applications intended to support or sustain life, or for any other application in which the failure of the Cypress Semiconductor product could create a situation where personal injury or death may

occur. Should Buyer purchase or use Cypress Semiconductor products for any such unintended or unauthorized application, Buyer shall indemnify and hold Cypress Semiconductor and its officers, employees, subsidiaries, affiliates and distributors harmless against all claims, costs, damages, expenses, and reasonable attorney fees arising out of, directly or indirectly, any claim of personal injury or death associated with such unintended or unauthorized use, even if such claim alleges that Cypress Semiconductor was negligent regarding the design or manufacture of the product.

The acceptance of this document will be construed as an acceptance of the foregoing conditions.

EZ-USB FX2 Technical Reference Manual,  
Version 2.0.

Copyright © 2000, 2001  
Cypress Semiconductor Corporation.

All rights reserved.

## List of Trademarks

Cypress, the Cypress Logo, EZ-USB, Making USB Universal, Xcelerator, and ReNumeration are trademarks or registered trademarks of Cypress Semiconductor Corporation. Macintosh is a registered trademark of Apple Computer, Inc. Windows is a registered trademark of Microsoft Corporation. I<sup>2</sup>C is a registered trademark of Philips Electronics. All other product or company names used in this manual may be trademarks, registered trademarks, or servicemarks of their respective owners.



# Table of Contents

## Chapter 1. Introducing EZ-USB FX2

1.1 Introduction.....	1-1
1.2 An Introduction to USB.....	1-1
1.3 The USB Specification .....	1-2
1.4 Host Is Master .....	1-3
1.5 USB Direction .....	1-3
1.6 Tokens and PIDs.....	1-3
1.6.1 Receiving Data from the Host.....	1-5
1.6.2 Sending Data to the Host .....	1-5
1.7 USB Frames.....	1-5
1.8 USB Transfer Types.....	1-6
1.8.1 Bulk Transfers .....	1-6
1.8.2 Interrupt Transfers .....	1-6
1.8.3 Isochronous Transfers.....	1-7
1.8.4 Control Transfers.....	1-7
1.9 Enumeration .....	1-8
1.9.1 Full-Speed / High-Speed Detection.....	1-8
1.10 The Serial Interface Engine (SIE).....	1-9
1.11 ReNumeration™.....	1-10
1.12 EZ-USB FX2 Architecture .....	1-11
1.13 FX2 Feature Summary .....	1-13
1.14 FX2 Integrated Microprocessor .....	1-13
1.15 FX2 Block Diagram .....	1-15
1.16 Packages.....	1-16
1.16.1 56-Pin Package .....	1-16
1.16.2 100-Pin Package .....	1-17
1.16.3 128-Pin Package .....	1-17
1.16.4 Signals Available in the Three Packages .....	1-17
1.17 Package Diagrams .....	1-20
1.18 FX2 Endpoint Buffers .....	1-23
1.19 External FIFO Interface .....	1-25
1.20 EZ-USB FX2 Product Family.....	1-28



*(Table of Contents)*

**Chapter 2. Endpoint Zero**

- 2.1 Introduction ..... 2-1
- 2.2 Control Endpoint EP0 ..... 2-2
- 2.3 USB Requests ..... 2-5
  - 2.3.1 Get Status..... 2-7
  - 2.3.2 Set Feature..... 2-10
  - 2.3.3 Clear Feature..... 2-11
  - 2.3.4 Get Descriptor ..... 2-12
    - 2.3.4.1 Get Descriptor-Device ..... 2-14
    - 2.3.4.2 Get Descriptor-Device Qualifier ..... 2-15
    - 2.3.4.3 Get Descriptor-Configuration ..... 2-15
    - 2.3.4.4 Get Descriptor-String ..... 2-16
    - 2.3.4.5 Get Descriptor-Other Speed Configuration ..... 2-16
  - 2.3.5 Set Descriptor..... 2-17
    - 2.3.5.1 Set Configuration ..... 2-20
  - 2.3.6 Get Configuration ..... 2-20
  - 2.3.7 Set Interface ..... 2-21
  - 2.3.8 Get Interface..... 2-22
  - 2.3.9 Set Address..... 2-22
  - 2.3.10 Sync Frame ..... 2-23
  - 2.3.11 Firmware Load..... 2-24

**Chapter 3. Enumeration and ReNumeration™**

- 3.1 Introduction ..... 3-1
- 3.2 FX2 Startup Modes ..... 3-1
- 3.3 The Default USB Device ..... 3-3
- 3.4 EEPROM Boot-load Data Formats..... 3-4
  - 3.4.1 No EEPROM or Invalid EEPROM..... 3-4
  - 3.4.2 Serial EEPROM Present, First Byte is 0xC0 ..... 3-5
  - 3.4.3 Serial EEPROM Present, First Byte is 0xC2 ..... 3-6
- 3.5 EEPROM Configuration Byte ..... 3-8
- 3.6 The RENUM Bit..... 3-9
- 3.7 FX2 Response to Device Requests (RENUM=0)..... 3-10
- 3.8 FX2 Vendor Request for Firmware Load..... 3-11
- 3.9 How the Firmware ReNumerates..... 3-12
- 3.10 Multiple ReNumerations™ ..... 3-12

**Chapter 4. Interrupts**

- 4.1 Introduction ..... 4-1



(Table of Contents)

- 4.2 SFRs ..... 4-2
  - 4.2.1 803x/805x Compatibility ..... 4-5
- 4.3 Interrupt Processing ..... 4-6
  - 4.3.1 Interrupt Masking ..... 4-6
    - 4.3.1.1 Interrupt Priorities ..... 4-7
  - 4.3.2 Interrupt Sampling ..... 4-8
  - 4.3.3 Interrupt Latency ..... 4-8
- 4.4 USB-Specific Interrupts ..... 4-8
  - 4.4.1 Resume Interrupt ..... 4-8
  - 4.4.2 USB Interrupts ..... 4-9
    - 4.4.2.1 SUTOK, SUDAV Interrupts ..... 4-12
    - 4.4.2.2 SOF Interrupt ..... 4-13
    - 4.4.2.3 Suspend Interrupt ..... 4-13
    - 4.4.2.4 USB RESET Interrupt ..... 4-13
    - 4.4.2.5 HISPEED Interrupt ..... 4-13
    - 4.4.2.6 EP0ACK Interrupt ..... 4-13
    - 4.4.2.7 Endpoint Interrupts ..... 4-14
    - 4.4.2.8 In-Bulk-NAK (IBN) Interrupt ..... 4-14
    - 4.4.2.9 EPxPING Interrupt ..... 4-14
    - 4.4.2.10 ERRLIMIT Interrupt ..... 4-15
    - 4.4.2.11 EPxISOERR Interrupt ..... 4-15
- 4.5 USB-Interrupt Autovectors ..... 4-15
  - 4.5.1 USB Autovector Coding ..... 4-17
- 4.6 I<sup>2</sup>C-Compatible Bus Interrupt ..... 4-18
- 4.7 FIFO/GPIF Interrupt (INT4) ..... 4-19
- 4.8 FIFO/GPIF-Interrupt Autovectors ..... 4-20
  - 4.8.1 FIFO/GPIF Autovector Coding ..... 4-21

**Chapter 5. Memory**

- 5.1 Introduction ..... 5-1
- 5.2 Internal Data RAM ..... 5-1
  - 5.2.1 The Lower 128 ..... 5-2
  - 5.2.2 The Upper 128 ..... 5-2
  - 5.2.3 SFR (Special Function Register) Space ..... 5-2
- 5.3 External Program Memory and External Data Memory ..... 5-3
  - 5.3.1 56- and 100-pin FX2 ..... 5-4
  - 5.3.2 128-pin FX2 ..... 5-4
- 5.4 FX2 Memory Maps ..... 5-5
- 5.5 “Von-Neumannizing” Off-Chip Program and Data Memory ..... 5-8
- 5.6 On-Chip Data Memory at 0xE000-0xFFFF ..... 5-9



*(Table of Contents)*

**Chapter 6. Power Management**

- 6.1 Introduction ..... 6-1
- 6.2 USB Suspend..... 6-3
  - 6.2.1 SUSPEND Register..... 6-4
- 6.3 Wakeup/Resume..... 6-4
  - 6.3.1 Wakeup Interrupt..... 6-5
- 6.4 USB Resume (Remote Wakeup) ..... 6-6
  - 6.4.1 WU2 Pin ..... 6-6

**Chapter 7. Resets**

- 7.1 Introduction ..... 7-1
- 7.2 Power-On Reset (POR)..... 7-2
- 7.3 Releasing the CPU Reset ..... 7-3
  - 7.3.1 RAM Download..... 7-3
  - 7.3.2 EEPROM Load ..... 7-3
  - 7.3.3 External ROM ..... 7-3
- 7.4 CPU Reset Effects ..... 7-4
- 7.5 USB Bus Reset ..... 7-4
- 7.6 FX2 Disconnect..... 7-5
- 7.7 Reset Summary ..... 7-5

**Chapter 8. Access to Endpoint Buffers**

- 8.1 Introduction ..... 8-1
- 8.2 FX2 Large and Small Endpoints..... 8-1
- 8.3 High-Speed and Full-Speed Differences ..... 8-2
- 8.4 How the CPU Configures the Endpoints ..... 8-3
- 8.5 CPU Access to FX2 Endpoint Data ..... 8-4
- 8.6 CPU Control of FX2 Endpoints ..... 8-5
  - 8.6.1 Registers That Control EP0, EP1IN, and EP1OUT ..... 8-5
    - 8.6.1.1 EP0CS ..... 8-5
    - 8.6.1.2 EP0BCH and EP0BCL ..... 8-7
    - 8.6.1.3 USBIE, USBIRQ ..... 8-7
    - 8.6.1.4 EP01STAT ..... 8-8
    - 8.6.1.5 EP1OUTCS..... 8-8
    - 8.6.1.6 EP1OUTBC..... 8-9
    - 8.6.1.7 EP1INCS..... 8-9
    - 8.6.1.8 EP1INBC..... 8-9
  - 8.6.2 Registers That Control EP2, EP4, EP6, EP8 ..... 8-10
    - 8.6.2.1 EP2468STAT ..... 8-10



(Table of Contents)

- 8.6.2.2 EP2ISOINPKTS, EP4ISOINPKTS, EP6ISOINPKTS, EP8ISOINPKTS ..... 8-10
- 8.6.2.3 EP2CS, EP4CS, EP6CS, EP8CS ..... 8-11
- 8.6.2.4 EP2BCH:L, EP4BCH:L, EP6BCH:L, EP8BCH:L..... 8-12
- 8.6.3 Registers That Control All Endpoints..... 8-13
  - 8.6.3.1 IBNIE, IBNIRQ, NAKIE, NAKIRQ..... 8-14
  - 8.6.3.2 EPIE, EPIRQ..... 8-15
  - 8.6.3.3 USBERRIE, USBERRIRQ, ERRCNTLIM, CLRERRCNT..... 8-16
  - 8.6.3.4 TOGCTL..... 8-16
- 8.7 The Setup Data Pointer ..... 8-17
  - 8.7.1 Transfer Length ..... 8-19
  - 8.7.2 Accessible Memory Spaces ..... 8-19
- 8.8 Autopointers ..... 8-19

**Chapter 9. Slave FIFOs**

- 9.1 Introduction..... 9-1
- 9.2 Hardware ..... 9-2
  - 9.2.1 Slave FIFO Pins ..... 9-3
  - 9.2.2 FIFO Data Bus (FD) ..... 9-4
  - 9.2.3 Interface Clock (IFCLK) ..... 9-5
  - 9.2.4 FIFO Flag Pins (FLAGA, FLAGB, FLAGC, FLAGD) ..... 9-6
  - 9.2.5 Control Pins (SLOE, SLRD, SLWR, PKTEND, FIFOADR[1:0])..... 9-8
  - 9.2.6 Slave FIFO Chip Select (SLCS) ..... 9-10
  - 9.2.7 Implementing Synchronous Slave FIFO Writes..... 9-10
  - 9.2.8 Implementing Synchronous Slave FIFO Reads..... 9-13
  - 9.2.9 Implementing Asynchronous Slave FIFO Writes ..... 9-15
  - 9.2.10 Implementing Asynchronous Slave FIFO Reads..... 9-17
- 9.3 Firmware ..... 9-19
  - 9.3.1 Firmware FIFO Access..... 9-20
  - 9.3.2 EPx Memories ..... 9-20
  - 9.3.3 Slave FIFO Programmable-Level Flag (PF) ..... 9-21
  - 9.3.4 Auto-In / Auto-Out Modes ..... 9-22
  - 9.3.5 CPU Access to OUT Packets, AUTOOUT = 1 ..... 9-23
  - 9.3.6 CPU Access to OUT Packets, AUTOOUT = 0 ..... 9-23
  - 9.3.7 CPU Access to IN Packets, AUTOIN = 1 ..... 9-26
  - 9.3.8 Access to IN Packets, AUTOIN=0..... 9-28
  - 9.3.9 Auto-In / Auto-Out Initialization ..... 9-29
  - 9.3.10 Auto-Mode Example: Synchronous FIFO IN Data Transfers ..... 9-30
  - 9.3.11 Auto-Mode Example: Asynchronous FIFO IN Data Transfers ..... 9-31



*(Table of Contents)*

**Chapter 10. General Programmable Interface (GPIF)**

- 10.1 Introduction ..... 10-1
  - 10.1.1 Typical GPIF Interface ..... 10-3
- 10.2 Hardware ..... 10-5
  - 10.2.1 The External GPIF Interface ..... 10-5
  - 10.2.2 Default GPIF Pins Configuration ..... 10-6
  - 10.2.3 Six Control OUT signals ..... 10-7
    - 10.2.3.1 Control Output Modes ..... 10-7
  - 10.2.4 Six Ready IN signals ..... 10-7
  - 10.2.5 Nine GPIF Address OUT signals ..... 10-7
  - 10.2.6 Three GSTATE OUT signals ..... 10-8
  - 10.2.7 8/16-Bit Data Path, WORDWIDE = 1 (default) and WORDWIDE = 0 ..... 10-8
  - 10.2.8 Byte Order for 16-bit GPIF Transactions ..... 10-8
  - 10.2.9 Interface Clock (IFCLK) ..... 10-8
  - 10.2.10 Connecting GPIF Signal Pins to Hardware ..... 10-10
  - 10.2.11 Example GPIF Hardware Interconnect ..... 10-10
- 10.3 Programming the GPIF Waveforms ..... 10-11
  - 10.3.1 The GPIF Registers ..... 10-12
  - 10.3.2 Programming GPIF Waveforms ..... 10-12
    - 10.3.2.1 The GPIF IDLE State ..... 10-12
      - 10.3.2.1.1 GPIF Data Bus During IDLE ..... 10-13
      - 10.3.2.1.2 CTL Outputs During IDLE ..... 10-13
    - 10.3.2.2 Defining States ..... 10-14
      - 10.3.2.2.1 Non-Decision Point (NDP) States ..... 10-14
      - 10.3.2.2.2 Decision Point (DP) States ..... 10-16
  - 10.3.3 Re-Executing a Task Within a DP State ..... 10-18
  - 10.3.4 State Instructions ..... 10-21
    - 10.3.4.1 Structure of the Waveform Descriptors ..... 10-25
- 10.4 Firmware ..... 10-26
  - 10.4.1 Single-Read Transactions ..... 10-33
  - 10.4.2 Single-Write Transactions ..... 10-38
  - 10.4.3 FIFO-Read and FIFO-Write Transactions ..... 10-41
    - 10.4.3.1 Transaction Counter ..... 10-41
    - 10.4.3.2 Reading the Transaction-Count Status in a DP State ..... 10-42
  - 10.4.4 GPIF Flag Selection ..... 10-42
  - 10.4.5 GPIF Flag Stop ..... 10-42
    - 10.4.5.1 Performing a FIFO-Read Transaction ..... 10-43
  - 10.4.6 Firmware Access to IN packet(s), (AUTOIN=1) ..... 10-48
  - 10.4.7 Firmware Access to IN Packet(s), (AUTOIN = 0) ..... 10-49
    - 10.4.7.1 Performing a FIFO-Write Transaction ..... 10-52





*(Table of Contents)*

- 10.4.8 Firmware access to OUT packets, (AUTOOUT=1) ..... 10-56
- 10.4.9 Firmware access to OUT packets, (AUTOOUT = 0) ..... 10-56
- 10.4.10 Burst FIFO Transactions ..... 10-58
- 10.5 UDMA Interface ..... 10-62

**Chapter 11. CPU Introduction**

- 11.1 Introduction..... 11-1
- 11.2 8051 Enhancements ..... 11-2
- 11.3 Performance Overview ..... 11-3
- 11.4 Software Compatibility..... 11-4
- 11.5 803x/805x Feature Comparison ..... 11-4
- 11.6 FX2/DS80C320 Differences ..... 11-5
  - 11.6.1 Serial Ports ..... 11-5
  - 11.6.2 Timer 2 ..... 11-5
  - 11.6.3 Timed Access Protection ..... 11-6
  - 11.6.4 Watchdog Timer ..... 11-6
  - 11.6.5 Power Fail Detection ..... 11-6
  - 11.6.6 Port I/O ..... 11-6
  - 11.6.7 Interrupts ..... 11-6
- 11.7 EZ-USB FX2 Register Interface ..... 11-7
- 11.8 EZ-USB FX2 Internal RAM..... 11-7
- 11.9 I/O Ports ..... 11-8
- 11.10 Interrupts ..... 11-9
- 11.11 Power Control..... 11-9
- 11.12 Special Function Registers (SFR) ..... 11-10
- 11.13 External Address/Data Buses ..... 11-11
- 11.14 Reset..... 11-11

**Chapter 12. Instruction Set**

- 12.1 Introduction..... 12-1
  - 12.1.1 Instruction Timing ..... 12-5
  - 12.1.2 Stretch Memory Cycles (Wait States)..... 12-5
  - 12.1.3 Dual Data Pointers ..... 12-7
  - 12.1.4 Special Function Registers ..... 12-7

**Chapter 13. Input/Output**

- 13.1 Introduction..... 13-1
- 13.2 I/O Ports ..... 13-1
- 13.3 I/O Port Alternate Functions ..... 13-5



*(Table of Contents)*

- 13.3.1 Port A Alternate Functions..... 13-7
- 13.3.2 Port B and Port D Alternate Functions ..... 13-8
- 13.3.3 Port C Alternate Functions ..... 13-9
- 13.3.4 Port E Alternate Functions..... 13-10
- 13.4 I<sup>2</sup>C-Compatible Bus Controller ..... 13-12
  - 13.4.1 Interfacing to I<sup>2</sup>C Peripherals..... 13-12
  - 13.4.2 Registers ..... 13-13
    - 13.4.2.1 Control Bits..... 13-14
    - 13.4.2.2 Status Bits ..... 13-15
  - 13.4.3 Sending Data..... 13-16
  - 13.4.4 Receiving Data ..... 13-16
- 13.5 EEPROM Boot Loader ..... 13-17

**Chapter 14. Timers/Counters and Serial Interface**

- 14.1 Introduction ..... 14-1
- 14.2 Timers/Counters..... 14-1
  - 14.2.1 803x/805x Compatibility ..... 14-2
  - 14.2.2 Timers 0 and 1..... 14-2
    - 14.2.2.1 Mode 0, 13-Bit Timer/Counter — Timer 0 and Timer 1..... 14-3
    - 14.2.2.2 Mode 1, 16-Bit Timer/Counter — Timer 0 and Timer 1..... 14-3
    - 14.2.2.3 Mode 2, 8-Bit Counter with Auto-Reload — Timer 0 and Timer 1..... 14-5
    - 14.2.2.4 Mode 3, Two 8-Bit Counters — Timer 0 Only ..... 14-6
  - 14.2.3 Timer Rate Control ..... 14-7
  - 14.2.4 Timer 2 ..... 14-8
    - 14.2.4.1 Timer 2 Mode Control ..... 14-9
  - 14.2.5 Timer 2 — 16-Bit Timer/Counter Mode ..... 14-10
    - 14.2.5.1 Timer 2 — 16-Bit Timer/Counter Mode with Capture..... 14-10
  - 14.2.6 Timer 2 — 16-Bit Timer/Counter Mode with Auto-Reload ..... 14-10
  - 14.2.7 Timer 2 — Baud Rate Generator Mode..... 14-11
- 14.3 Serial Interface ..... 14-12
  - 14.3.1 803x/805x Compatibility ..... 14-13
  - 14.3.2 High-Speed Baud Rate Generator ..... 14-14
  - 14.3.3 Mode 0..... 14-15
  - 14.3.4 Mode 1..... 14-20
    - 14.3.4.1 Mode 1 Baud Rate ..... 14-20
    - 14.3.4.2 Mode 1 Transmit ..... 14-22
  - 14.3.5 Mode 1 Receive..... 14-22
  - 14.3.6 Mode 2..... 14-24
    - 14.3.6.1 Mode 2 Transmit ..... 14-24
    - 14.3.6.2 Mode 2 Receive ..... 14-25



(Table of Contents)

14.3.7 Mode 3 ..... 14-26

**Chapter 15. Registers**

15.1 Introduction..... 15-1  
    15.1.1 Example Register Formats ..... 15-1  
    15.1.2 Other Conventions..... 15-2  
15.2 Special Function Registers (SFR) ..... 15-3  
15.3 About SFRS ..... 15-4  
15.4 GPIF Waveform Memories ..... 15-13  
    15.4.1 GPIF Waveform Descriptor Data ..... 15-13  
15.5 General Configuration Registers ..... 15-13  
    15.5.1 CPU Control and Status ..... 15-13  
    15.5.2 Interface Configuration (Ports, GPIF, slave FIFOs) ..... 15-14  
    15.5.3 Slave FIFO FLAGA-FLAGD Pin Configuration ..... 15-18  
    15.5.4 FIFO Reset ..... 15-20  
    15.5.5 Breakpoint, Breakpoint Address High, Breakpoint Address Low ..... 15-20  
    15.5.6 230 Kbaud Clock (T0, T1, T2) ..... 15-22  
    15.5.7 Slave FIFO Interface Pins Polarity ..... 15-22  
    15.5.8 Chip Revision ID ..... 15-23  
    15.5.9 GPIF Hold Time ..... 15-24  
15.6 Endpoint Configuration ..... 15-25  
    15.6.1 Endpoint 1-OUT/Endpoint 1-IN Configurations ..... 15-25  
    15.6.2 Endpoint 2, 4, 6 and 8 Configuration ..... 15-26  
    15.6.3 Endpoint 2, 4, 6 and 8/Slave FIFO Configuration ..... 15-28  
    15.6.4 Endpoint 2, 4, 6, 8 AUTOIN Packet Length (High/Low) ..... 15-30  
    15.6.5 Endpoint 2, 4, 6, 8 /Slave FIFO Programmable-Level Flag (High/Low) .... 15-32  
        15.6.5.1 IN Endpoints..... 15-38  
        15.6.5.2 OUT Endpoints..... 15-39  
    15.6.6 Endpoint 2, 4, 6, 8 ISO IN Packets per Frame ..... 15-40  
    15.6.7 Force IN Packet End ..... 15-40  
15.7 Interrupts ..... 15-41  
    15.7.1 Endpoint 2, 4, 6, 8 Slave FIFO Flag Interrupt Enable/Request ..... 15-41  
    15.7.2 IN-BULK-NAK Interrupt Enable/Request ..... 15-43  
    15.7.3 Endpoint Ping-NAK/IBN Interrupt Enable/Request ..... 15-44  
    15.7.4 USB Interrupt Enable/Request ..... 15-45  
    15.7.5 Endpoint Interrupt Enable/Request ..... 15-47  
    15.7.6 GPIF Interrupt Enable/Request ..... 15-48  
    15.7.7 USB Error Interrupt Enable/Request ..... 15-49  
    15.7.8 USB Error Counter Limit ..... 15-50  
    15.7.9 Clear Error Count ..... 15-50



*(Table of Contents)*

- 15.7.10 INT 2 (USB) Autovector ..... 15-51
- 15.7.11 INT 4 (slave FIFOs & GPIF) Autovector ..... 15-51
- 15.7.12 INT 2 and INT 4 Setup ..... 15-52
- 15.8 Input/Output Registers ..... 15-53
  - 15.8.1 I/O PORTA Alternate Configuration ..... 15-53
  - 15.8.2 I/O PORTC Alternate Configuration ..... 15-54
  - 15.8.3 I/O PORTE Alternate Configuration ..... 15-54
  - 15.8.4 I<sup>2</sup>C Compatible Bus Control and Status ..... 15-55
  - 15.8.5 I<sup>2</sup>C-Compatible Bus Data ..... 15-57
  - 15.8.6 I<sup>2</sup>C-Compatible Bus Control ..... 15-57
  - 15.8.7 AUTOPOINTERS 1 and 2 MOVX access ..... 15-58
- 15.9 UDMA CRC Registers ..... 15-59
- 15.10 USB Control ..... 15-61
  - 15.10.1 USB Control and Status ..... 15-61
  - 15.10.2 Enter Suspend State ..... 15-62
  - 15.10.3 Wakeup Control & Status ..... 15-62
  - 15.10.4 Data Toggle Control ..... 15-63
  - 15.10.5 USB Frame Count High ..... 15-64
  - 15.10.6 USB Frame Count Low ..... 15-65
  - 15.10.7 USB Microframe Count ..... 15-65
  - 15.10.8 USB Function Address ..... 15-66
- 15.11 Endpoints ..... 15-66
  - 15.11.1 Endpoint 0 (Byte Count High) ..... 15-66
  - 15.11.2 Endpoint 0 Control and Status (Byte Count Low) ..... 15-67
  - 15.11.3 Endpoint 1 OUT and IN Byte Count ..... 15-67
  - 15.11.4 Endpoint 2 and 6 Byte Count High ..... 15-68
  - 15.11.5 Endpoint 4 and 8 Byte Count High ..... 15-68
  - 15.11.6 Endpoint 2, 4, 6, 8 Byte Count Low ..... 15-69
  - 15.11.7 Endpoint 0 Control and Status ..... 15-69
  - 15.11.8 Endpoint 1 OUT/IN Control and Status ..... 15-70
  - 15.11.9 Endpoint 2 Control and Status ..... 15-72
  - 15.11.10 Endpoint 4 Control and Status ..... 15-72
  - 15.11.11 Endpoint 6 Control and Status ..... 15-73
  - 15.11.12 Endpoint 8 Control and Status ..... 15-74
  - 15.11.13 Endpoint 2 and 4 Slave FIFO Flags ..... 15-75
  - 15.11.14 Endpoint 6 and 8 Slave FIFO Flags ..... 15-75
  - 15.11.15 Endpoint 2 Slave FIFO Byte Count High ..... 15-76
  - 15.11.16 Endpoint 6 Slave FIFO Total Byte Count High ..... 15-76
  - 15.11.17 Endpoint 4 and 8 Slave FIFO Byte Count High ..... 15-77
  - 15.11.18 Endpoint 2, 4, 6, 8 Slave FIFO Byte Count Low ..... 15-77



(Table of Contents)

- 15.11.19 Setup Data Pointer High and Low Address ..... 15-78
- 15.11.20 Setup Data Pointer Auto ..... 15-79
- 15.11.21 Setup Data - 8 Bytes ..... 15-80
- 15.12 General Programmable Interface (GPIF) ..... 15-81
  - 15.12.1 GPIF Waveform Selector ..... 15-81
  - 15.12.2 GPIF Done and Idle Drive Mode ..... 15-81
  - 15.12.3 CTL Outputs ..... 15-82
  - 15.12.4 GPIF Address High ..... 15-84
  - 15.12.5 GPIF Address Low ..... 15-85
  - 15.12.6 GPIF Flowstate Registers ..... 15-85
  - 15.12.7 Endpoint 2, 4, 6, 8 GPIF Transaction Count High ..... 15-93
  - 15.12.8 Endpoint 2, 4, 6, 8 GPIF Transaction Count Low ..... 15-94
  - 15.12.9 Endpoint 2, 4, 6, 8 GPIF Flag Select ..... 15-95
  - 15.12.10 Endpoint 2, 4, 6, and 8 GPIF Stop Transaction ..... 15-96
  - 15.12.11 Endpoint 2, 4, 6, and 8 Slave FIFO GPIF Trigger ..... 15-96
  - 15.12.12 GPIF Data High (16-Bit Mode) ..... 15-97
  - 15.12.13 Read/Write GPIF Data LOW & Trigger Transaction ..... 15-97
  - 15.12.14 Read GPIF Data LOW, No Transaction Trigger ..... 15-98
  - 15.12.15 GPIF RDY Pin Configuration ..... 15-98
  - 15.12.16 GPIF RDY Pin Status ..... 15-99
  - 15.12.17 Abort GPIF Cycles ..... 15-99
- 15.13 Endpoint Buffers ..... 15-100
  - 15.13.1 EP0 IN-OUT Buffer ..... 15-100
  - 15.13.2 Endpoint 1-OUT Buffer ..... 15-100
  - 15.13.3 Endpoint 1-IN Buffer ..... 15-101
  - 15.13.4 Endpoint 2/Slave FIFO Buffer ..... 15-101
  - 15.13.5 512-byte Endpoint 4/Slave FIFO Buffer ..... 15-102
  - 15.13.6 512/1024-byte Endpoint 6/Slave FIFO Buffer ..... 15-102
  - 15.13.7 512-byte Endpoint 8/Slave FIFO Buffer ..... 15-103
- 15.14 Synchronization Delay ..... 15-103

**Appendix A**

- Default Descriptors for Full Speed Mode ..... Appendix - 1

**Appendix B**

- Default Descriptors for High Speed Mode ..... Appendix - 11

**Appendix C**

- FX2 Register Summary ..... Appendix - 23





## List of Figures

Figure 1-1.	USB Packets .....	1-4
Figure 1-2.	Two Bulk Transfers, IN and OUT .....	1-6
Figure 1-3.	An Interrupt Transfer .....	1-6
Figure 1-4.	An Isochronous Transfer .....	1-7
Figure 1-5.	A Control Transfer .....	1-7
Figure 1-6.	What the SIE Does .....	1-9
Figure 1-7.	FX2 56-pin Package Simplified Block Diagram .....	1-11
Figure 1-8.	FX2 128-pin Package Simplified Block Diagram .....	1-12
Figure 1-9.	FX2 Block Diagram .....	1-15
Figure 1-10.	56-pin, 100-pin, and 128-pin FX2 Packages .....	1-16
Figure 1-11.	Signals for the Three FX2 Package Types .....	1-19
Figure 1-12.	CY7C68013-128 TQFP Pin Assignment .....	1-20
Figure 1-13.	CY7C68013-100 TQFP Pin Assignment .....	1-21
Figure 1-14.	CY7C68013-56 SSOP Pin Assignment .....	1-22
Figure 1-15.	FX2 Endpoint Buffers .....	1-23
Figure 1-16.	FX2 FIFOs in “Slave FIFO” Mode .....	1-26
Figure 1-17.	FX2 FIFOs in “GPIF Master” Mode .....	1-27
Figure 2-1.	A USB Control Transfer (With Data Stage) .....	2-2
Figure 2-2.	Two Interrupts Associated with EP0 CONTROL Transfers .....	2-3
Figure 2-3.	Registers Associated with EP0 Control Transfers .....	2-4
Figure 2-4.	Data Flow for a Get_Status Request .....	2-7
Figure 2-5.	Using Setup Data Pointer (SUDPTR) for Get_Descriptor Requests .....	2-13
Figure 3-1.	EEPROM Configuration Byte .....	3-8
Figure 3-2.	USB Control and Status Register .....	3-12
Figure 4-1.	USB Interrupts .....	4-10
Figure 4-2.	The Order of Clearing Interrupt Requests is Important .....	4-12
Figure 4-3.	SUTOK and SUDAV Interrupts .....	4-12
Figure 4-4.	A Start Of Frame (SOF) Packet .....	4-13
Figure 4-5.	The USB Autovector Mechanism in Action .....	4-17
Figure 4-6.	I <sup>2</sup> C-Compatible Bus Interrupt-Enable Bits and Registers .....	4-18
Figure 4-7.	The FIFO/GPIF Autovector Mechanism in Action .....	4-22



*(List of Figures)*

Figure 5-1.	Internal Data RAM Organization .....	5-1
Figure 5-2.	FX2 External Program/Data Memory Map, EA=0 .....	5-5
Figure 5-3.	FX2 External Program/Data Memory Map, EA=1 .....	5-7
Figure 5-4.	On-Chip Data Memory at 0xE000-0xFFFF .....	5-9
Figure 6-1.	Suspend-Resume Control .....	6-2
Figure 6-2.	USB Suspend sequence .....	6-3
Figure 6-3.	FX2 Wakeup/Resume sequence .....	6-4
Figure 6-4.	USB Control and Status register .....	6-6
Figure 7-1.	EZ-USB FX2 Resets .....	7-1
Figure 9-1.	Slave FIFOs' Role in the FX2 System .....	9-2
Figure 9-2.	FX2 Slave Mode Full-Featured Interface Pins .....	9-3
Figure 9-3.	Asynchronous vs. Synchronous Timing Models .....	9-3
Figure 9-4.	8-bit Mode Slave FIFOs, WORDWIDE=0 .....	9-4
Figure 9-5.	16-bit Mode Slave FIFOs, WORDWIDE=1 .....	9-5
Figure 9-6.	IFCLK Configuration .....	9-6
Figure 9-7.	Satisfying Setup Timing by Inverting the IFCLK Output .....	9-6
Figure 9-8.	FLAGx Role .....	9-7
Figure 9-9.	Slave FIFO Control Pins .....	9-9
Figure 9-10.	Interface Pins Example: Synchronous FIFO Writes .....	9-10
Figure 9-11.	State Machine Example: Synchronous FIFO Writes .....	9-11
Figure 9-12.	Timing Example: Synchronous FIFO Writes, Waveform 1 .....	9-11
Figure 9-13.	Timing Example: Synchronous FIFO Writes, Waveform 2 .....	9-12
Figure 9-14.	Timing Example: Synchronous FIFO Writes, Waveform 3, PKTEND Pin Illustrated .....	9-12
Figure 9-15.	Interface Pins Example: Synchronous FIFO Reads .....	9-13
Figure 9-16.	State Machine Example: Synchronous FIFO Reads .....	9-13
Figure 9-17.	Timing Example: Synchronous FIFO Reads, Waveform 1 .....	9-14
Figure 9-18.	Timing Example: Synchronous FIFO Reads, Waveform 2, EMPTY Flag Illustrated .....	9-14
Figure 9-19.	Interface Pins Example: Asynchronous FIFO Writes .....	9-15
Figure 9-20.	State Machine Example: Asynchronous FIFO Writes .....	9-15
Figure 9-21.	Timing Example: Asynchronous FIFO Writes .....	9-16
Figure 9-22.	Interface Pins Example: Asynchronous FIFO Reads .....	9-17
Figure 9-23.	State Machine Example: Asynchronous FIFO Reads .....	9-17
Figure 9-24.	Timing Example: Asynchronous FIFO Reads .....	9-18





(List of Figures)

Figure 9-25.	Firmware Access to IN Data .....	9-19
Figure 9-26.	Firmware Access to OUT Data .....	9-19
Figure 9-27.	EPxFIFOBUF Registers .....	9-20
Figure 9-28.	EPx Memories .....	9-21
Figure 9-29.	When AUTOOUT=1, OUT Packets are Automatically Committed .....	9-22
Figure 9-30.	TD_Init Example: Configuring AUTOOUT = 1 .....	9-22
Figure 9-31.	TD_Init Example: Configuring AUTOIN = 1 .....	9-23
Figure 9-32.	TD_Poll Example: No Code Necessary for OUT Packets When AUTOOUT=1 .....	9-23
Figure 9-33.	TD_Init Example, AUTOOUT=0 .....	9-23
Figure 9-34.	Skip or Commit, AUTOOUT=0 .....	9-24
Figure 9-35.	TD_Poll Example, AUTOOUT=0, Commit Packet .....	9-24
Figure 9-36.	TD_Poll Example, AUTOOUT=0, Skip Packet .....	9-24
Figure 9-37.	TD_Poll Example, AUTOOUT=0, Commit or Skip .....	9-25
Figure 9-38.	TD_Init Example, OUT Endpoint Initialization .....	9-25
Figure 9-39.	TD_Poll Example, AUTOIN = 1 .....	9-26
Figure 9-40.	Master Writes Directly to Host, AUTOIN = 1 .....	9-26
Figure 9-41.	Firmware Intervention, AUTOIN = 0 or 1 .....	9-27
Figure 9-42.	TD_Poll Example: Sourcing a Packet .....	9-27
Figure 9-43.	TD_Poll Example, AUTOIN=0, Committing a Packet via INPKTEND .....	9-28
Figure 9-44.	TD_Poll Example, AUTOIN=0, Committing a Packet via EPxBCH:L .....	9-29
Figure 9-45.	Code Example, Synchronous Slave FIFO IN Data Transfer .....	9-30
Figure 9-46.	TD_Init Example, Asynchronous Slave FIFO IN Data Transfers .....	9-31
Figure 9-47.	TD_Poll Example, Asynchronous Slave FIFO IN Data Transfers .....	9-31
Figure 10-1.	GPIF's Place in the FX2 System .....	10-2
Figure 10-2.	Example GPIF Waveform .....	10-3
Figure 10-3.	EZ-USB FX2 Interfacing to a Peripheral .....	10-4
Figure 10-4.	IFCLK Configuration .....	10-9
Figure 10-5.	Satisfying Setup Timing by Inverting the IFCLK Output .....	10-9
Figure 10-6.	GPIF State Machine Overview .....	10-11
Figure 10-7.	Non-Decision Point (NDP) States .....	10-15
Figure 10-8.	One Decision Point: Wait States Inserted Until RDY0 Goes Low .....	10-17
Figure 10-9.	One Decision Point: No Wait States Inserted: RDY0 is Already Low at Decision Point I1 .....	10-17
Figure 10-10.	Re-Executing a Task within a DP State .....	10-19



*(List of Figures)*

Figure 10-11.	GPIFTool Setup for the Waveform of Figure 10-10 .....	10-19
Figure 10-12.	A DP State Which Does NOT Re-Execute the Task .....	10-20
Figure 10-13.	GPIFTool Setup for the Waveform of Figure 10-12 .....	10-20
Figure 10-14.	Firmware Launches a Single-Read Waveform, WORDWIDE=0 .....	10-33
Figure 10-15.	Single-Read Transaction Waveform .....	10-34
Figure 10-16.	GPIFTool Setup for the Waveform of Figure 10-15 .....	10-34
Figure 10-17.	Single-Read Transaction Functions .....	10-36
Figure 10-18.	Initialization Code for Single-Read Transactions .....	10-37
Figure 10-19.	Firmware Launches a Single-Write Waveform, WORDWIDE=0 .....	10-38
Figure 10-20.	Single-Write Transaction Waveform .....	10-39
Figure 10-21.	GPIFTool Setup for the Waveform of Figure 10-20 .....	10-39
Figure 10-22.	Single-Write Transaction Functions .....	10-40
Figure 10-23.	Initialization Code for Single-Write Transactions .....	10-41
Figure 10-24.	Firmware Launches a FIFO-Read Waveform .....	10-43
Figure 10-25.	Example FIFO-Read Transaction .....	10-43
Figure 10-26.	FIFO-Read Transaction Waveform .....	10-44
Figure 10-27.	GPIFTool Setup for the Waveform of Figure 10-26 .....	10-45
Figure 10-28.	FIFO-Read Transaction Functions .....	10-46
Figure 10-29.	Initialization Code for FIFO-Read Transactions .....	10-47
Figure 10-30.	FIFO-Read w/ AUTOIN = 0, Committing Packets via INPKTEND .....	10-47
Figure 10-31.	FIFO-Read w/ AUTOIN = 0, Committing Packets via EPxBCL .....	10-48
Figure 10-32.	AUTOIN=1, GPIF FIFO Read Transactions, AUTOIN = 1 .....	10-48
Figure 10-33.	FIFO-Read Transaction Code, AUTOIN = 1 .....	10-49
Figure 10-34.	Firmware intervention, AUTOIN = 0/1 .....	10-49
Figure 10-35.	Committing a Packet by Writing INPKTEND with EPx Number .....	10-50
Figure 10-36.	Committing a Packet by Writing to EPxBCL .....	10-50
Figure 10-37.	Firmware Packet-Sourcing .....	10-51
Figure 10-38.	Firmware Launches a FIFO-Write Waveform .....	10-52
Figure 10-39.	Example FIFO-Write Transaction .....	10-52
Figure 10-40.	FIFO-Write Transaction Waveform .....	10-53
Figure 10-41.	GPIFTool Setup for the Waveform of Figure 10-40 .....	10-53
Figure 10-42.	FIFO-Write Transaction Functions .....	10-54
Figure 10-43.	Initialization Code for FIFO-Write Transactions .....	10-55
Figure 10-44.	FIFO-Write w/ AUTOOUT = 0, Committing Packets via EPxBCL .....	10-55
Figure 10-45.	CPU not in data path, AUTOOUT=1 .....	10-56



(List of Figures)

Figure 10-46.	FIFO-Write Transaction Code, AUTOOUT = 1 .....	10-56
Figure 10-47.	Firmware can Skip or Commit, AUTOOUT = 0 .....	10-56
Figure 10-48.	Initialization Code for AUTOOUT = 0 .....	10-57
Figure 10-49.	Committing an OUT Packet by Writing EPxBCL.7 = 0 .....	10-57
Figure 10-50.	Skipping an OUT Packet by Writing EPxBCL.7 = 0 .....	10-57
Figure 10-51.	Modifying the Contents of an OUT Packet (AUTOOUT = 0) .....	10-58
Figure 10-52.	Ensuring that the FIFO is Clear after Power-On-Reset .....	10-58
Figure 10-53.	Burst FIFO-Read Transaction Functions .....	10-59
Figure 10-54.	Initialization for Burst FIFO-Read Transactions .....	10-60
Figure 10-55.	Burst FIFO-Read Transaction Example, Writing INPKTEND to Commit .....	10-61
Figure 10-56.	Burst FIFO-Read Transaction Example, Writing EPxBCL to Commit .....	10-62
Figure 11-1.	FX2 CPU Features .....	11-1
Figure 11-2.	FX2 to Standard 8051 Timing Comparison .....	11-4
Figure 11-1.	FX2 Internal Data RAM .....	11-7
Figure 13-1.	FX2 I/O Pin .....	13-2
Figure 13-2.	I/O Port Output-Enable Registers .....	13-3
Figure 13-3.	I/O Port Data Registers .....	13-4
Figure 13-4.	I/O-Pin Logic when Alternate Function is an OUTPUT .....	13-5
Figure 13-5.	I/O-Pin Logic when Alternate Function is an INPUT .....	13-6
Figure 13-6.	General I <sup>2</sup> C Transfer .....	13-12
Figure 13-7.	Addressing an I <sup>2</sup> C Peripheral .....	13-13
Figure 13-8.	I <sup>2</sup> C-Compatible Registers .....	13-14
Figure 14-1.	Timer 0/1 - Modes 0 and 1 .....	14-3
Figure 14-2.	Timer 0/1 - Mode 2 .....	14-6
Figure 14-3.	Timer 0 - Mode 3 .....	14-7
Figure 14-4.	Timer 2 - Timer/Counter with Capture .....	14-10
Figure 14-5.	Timer 2 - Timer/Counter with Auto Reload .....	14-11
Figure 14-6.	Timer 2 - Baud Rate Generator Mode .....	14-12
Figure 14-7.	Serial Port Mode 0 Receive Timing - Low Speed Operation .....	14-18
Figure 14-8.	Serial Port Mode 0 Receive Timing - High Speed Operation .....	14-18
Figure 14-9.	Serial Port Mode 0 Transmit Timing - Low Speed Operation .....	14-19
Figure 14-10.	Serial Port Mode 0 Transmit Timing - High Speed Operation .....	14-19
Figure 14-11.	Serial Port 0 Mode 1 Transmit Timing .....	14-23
Figure 14-12.	Serial Port 0 Mode 1 Receive Timing .....	14-24
Figure 14-13.	Serial Port 0 Mode 2 Transmit Timing .....	14-25



*(List of Figures)*

Figure 14-14.	Serial Port 0 Mode 2 Receive Timing .....	14-26
Figure 14-15.	Serial Port 0 Mode 3 Transmit Timing .....	14-27
Figure 14-16.	Serial Port 0 Mode 3 Receive Timing .....	14-27
Figure 15-1.	Register Description Format .....	15-2
Figure 15-2.	Single Instruction to Read Port B .....	15-4
Figure 15-3.	Single Instruction to Write to Port C .....	15-4
Figure 15-4.	Use Bit 2 to set PORTD - Single Instruction .....	15-9
Figure 15-5.	Use OR to Set Bit 3 .....	15-10
Figure 15-6.	GPIF Waveform Descriptor Data .....	15-13
Figure 15-7.	CPU Control and Status .....	15-13
Figure 15-8.	Interface Configuration (Ports, GPIF, slave FIFOs) .....	15-14
Figure 15-9.	IFCLK Configuration .....	15-15
Figure 15-10.	Slave FIFO FLAGA-FLAGD Pin Configuration .....	15-18
Figure 15-11.	Restore FIFOs to Reset State .....	15-20
Figure 15-12.	Breakpoint Control .....	15-20
Figure 15-13.	Breakpoint Address High .....	15-21
Figure 15-14.	Breakpoint Address Low .....	15-21
Figure 15-15.	230 Kbaud Internally Generated Reference Clock .....	15-22
Figure 15-16.	Slave FIFO Interface Pins Polarity .....	15-22
Figure 15-17.	Chip Revision ID .....	15-23
Figure 15-18.	Endpoint 1-OUT/Endpoint 1-IN Configurations .....	15-25
Figure 15-19.	Endpoint 2 Configuration .....	15-26
Figure 15-20.	Endpoint 4 Configuration .....	15-26
Figure 15-21.	Endpoint 6 Configuration .....	15-26
Figure 15-22.	Endpoint 8 Configuration .....	15-26
Figure 15-23.	Endpoint 2, 4, 6 and 8 /Slave FIFO Configuration .....	15-28
Figure 15-24.	Endpoint 2 and 6 AUTOIN Packet Length High .....	15-30
Figure 15-25.	Endpoint 4 and 8 AUTOIN Packet Length High .....	15-30
Figure 15-26.	Endpoint 2, 4, 6, 8 AUTOIN Packet Length Low .....	15-31
Figure 15-27.	Endpoint 2/Slave FIFO Programmable Flag High .....	15-32
Figure 15-28.	Endpoint 6/Slave FIFO Programmable Flag High .....	15-33
Figure 15-29.	Endpoint 4/Slave FIFO Programmable Flag High .....	15-35
Figure 15-30.	Endpoint 8/Slave FIFO Programmable Flag High .....	15-36
Figure 15-31.	Endpoint 2, 4, 6, 8/Slave FIFO Programmable Flag Low .....	15-37
Figure 15-32.	Maximum FIFO Sizes .....	15-39



*(List of Figures)*

Figure 15-33.	Endpoint ISO IN Packets per Frame .....	15-40
Figure 15-34.	Force IN Packet End .....	15-40
Figure 15-35.	Endpoint 2, 4, 6, 8 Slave FIFO Flag Interrupt Enable .....	15-41
Figure 15-36.	Endpoint 2, 4, 6, 8 Slave FIFO Flag Interrupt Request .....	15-42
Figure 15-37.	IN-BULK-NAK Interrupt Enable .....	15-43
Figure 15-38.	IN-BULK-NAK Interrupt Request .....	15-43
Figure 15-39.	Endpoint Ping-NAK/IBN Interrupt Enable .....	15-44
Figure 15-40.	Endpoint Ping-NAK/IBN Interrupt Request .....	15-44
Figure 15-41.	USB Interrupt Enables .....	15-45
Figure 15-42.	USB Interrupt Requests .....	15-45
Figure 15-43.	Endpoint Interrupt Enables .....	15-47
Figure 15-44.	Endpoint Interrupt Requests .....	15-47
Figure 15-45.	GPIF Interrupt Enable .....	15-48
Figure 15-46.	GPIF Interrupt Request .....	15-48
Figure 15-47.	USB Error Interrupt Enables .....	15-49
Figure 15-48.	USB Error Interrupt Request .....	15-49
Figure 15-49.	USB Error Counter and Limit .....	15-50
Figure 15-50.	Clear Error Count EC3:0 .....	15-50
Figure 15-51.	INT 2 (USB) Autovector .....	15-51
Figure 15-52.	INT 4 (slave FIFOs & GPIF) Autovector .....	15-51
Figure 15-53.	INT 2 and INT 4 Setup .....	15-52
Figure 15-54.	I/O PORTA Alternate Configuration .....	15-53
Figure 15-55.	I/O PORTC Alternate Configuration .....	15-54
Figure 15-56.	I/O PORTE Alternate Configuration .....	15-54
Figure 15-57.	I <sup>2</sup> C-Compatible Bus Control and Status .....	15-55
Figure 15-58.	I <sup>2</sup> C-Compatible Bus Data .....	15-57
Figure 15-59.	I <sup>2</sup> C-Compatible Bus Control .....	15-57
Figure 15-60.	AUTOPTR1 & AUTOPTR2 MOVX access (when EXTACC=1) .....	15-58
Figure 15-61.	USB Control and Status .....	15-61
Figure 15-62.	Enter Suspend State .....	15-62
Figure 15-63.	Wakeup Control & Status .....	15-62
Figure 15-64.	Data Toggle Control .....	15-63
Figure 15-65.	USB Frame Count HIGH .....	15-64
Figure 15-66.	USB Frame Count Low .....	15-65
Figure 15-67.	USB Microframe Count .....	15-65



*(List of Figures)*

Figure 15-68.	USB Function Address .....	15-66
Figure 15-69.	Endpoint 0 (Byte Count High) .....	15-66
Figure 15-70.	Endpoint 0 Control and Status (Byte Count Low) .....	15-67
Figure 15-71.	Endpoint 1 OUT/IN Byte Count .....	15-67
Figure 15-72.	Endpoint 2 and 6 Byte Count High .....	15-68
Figure 15-73.	Endpoint 4 and 5 Byte Count High .....	15-68
Figure 15-74.	Endpoint 2, 4, 6, 8 Byte Count Low .....	15-69
Figure 15-75.	Endpoint 0 Control and Status .....	15-69
Figure 15-76.	Endpoint 1 OUT/IN Control and Status .....	15-70
Figure 15-77.	Endpoint 2 Control and Status .....	15-72
Figure 15-78.	Endpoint 4 Control and Status .....	15-72
Figure 15-79.	Endpoint 6 Control and Status .....	15-73
Figure 15-80.	Endpoint 8 Control and Status .....	15-74
Figure 15-81.	Endpoint 2 and 4 Slave FIFO Flags .....	15-75
Figure 15-82.	Endpoint 6 and 8 Slave FIFO Flags .....	15-75
Figure 15-83.	Endpoint 2 Slave FIFO Total Byte Count High .....	15-76
Figure 15-84.	Endpoint 6 Slave FIFO Total Byte Count High .....	15-76
Figure 15-85.	Endpoint 4 and 8 Slave FIFO Byte Count High .....	15-77
Figure 15-86.	Endpoint 2, 4, 6, 8 Slave FIFO Byte Count Low .....	15-77
Figure 15-87.	Setup Data Pointer High Address Byte .....	15-78
Figure 15-88.	Setup Data Pointer Low Address Byte .....	15-78
Figure 15-89.	Setup Data Pointer AUTO Mode .....	15-79
Figure 15-90.	Setup Data - 8 Bytes .....	15-80
Figure 15-91.	GPIF Waveform Selector .....	15-81
Figure 15-92.	GPIF Done and Idle Drive .....	15-81
Figure 15-93.	CTL Output States in Idle .....	15-82
Figure 15-94.	CTL Output Drive Type .....	15-82
Figure 15-95.	GPIF Address High .....	15-84
Figure 15-96.	GPIF Address Low .....	15-85
Figure 15-97.	Endpoint 2, 4, 6, 8 GPIF Transaction Count High .....	15-93
Figure 15-98.	Endpoint 2, 4, 6, 8 GPIF Transaction Count Low .....	15-94
Figure 15-99.	Endpoint 2, 4, 6, 8 GPIF Flag Select .....	15-95
Figure 15-100.	Endpoint 2, 4, 6, and 8 GPIF Stop Transaction .....	15-96
Figure 15-101.	Endpoint 2, 4, 6, and 8 Slave FIFO GPIF Trigger .....	15-96
Figure 15-102.	GPIF Data High (16-Bit Mode) .....	15-97



*(List of Figures)*

Figure 15-103. Read/Write GPIF Data LOW & Trigger Transaction .....	15-97
Figure 15-104. Read GPIF Data LOW, No Transaction Trigger .....	15-98
Figure 15-105. GPIF Ready Pins .....	15-98
Figure 15-106. GPIF Ready Status Pins .....	15-99
Figure 15-107. Abort GPIF .....	15-99
Figure 15-108. EP0 IN/OUT Buffer .....	15-100
Figure 15-109. EP1-OUT Buffer .....	15-100
Figure 15-110. EP1-IN Buffer .....	15-101
Figure 15-111. 512/1024-byte EP2/Slave FIFO Buffer .....	15-101
Figure 15-112. 512-byte EP4/Slave FIFO Buffer .....	15-102
Figure 15-113. 512/1024-byte EP6/Slave FIFO Buffer .....	15-102
Figure 15-114. 512-byte EP8/Slave FIFO Buffer .....	15-103







## List of Tables

Table 1-1.	USB PIDS	1-3
Table 1-2.	Endpoint 2, 4, 6, and 8 Configuration Choices	1-24
Table 1-3.	EZ-USB FX2 Family	1-28
Table 2-1.	The Eight Bytes in a USB SETUP Packet	2-5
Table 2-2.	How the Firmware Handles USB Device Requests (RENUM=1)	2-6
Table 2-3.	Get Status-Device (Remote Wakeup and Self-Powered Bits)	2-8
Table 2-4.	Get Status-Endpoint (Stall Bits)	2-8
Table 2-5.	Get Status-Interface	2-9
Table 2-6.	Set Feature-Device (Set Remote Wakeup Bit)	2-10
Table 2-7.	Set Feature-Endpoint (Stall)	2-10
Table 2-8.	Clear Feature-Device (Clear Remote Wakeup Bit)	2-11
Table 2-9.	Clear Feature-Endpoint (Clear Stall)	2-12
Table 2-10.	Get Descriptor-Device	2-14
Table 2-11.	Get Descriptor-Device Qualifier	2-15
Table 2-12.	Get Descriptor-Configuration	2-15
Table 2-13.	Get Descriptor-String	2-16
Table 2-14.	Get Descriptor-Other Speed Configuration	2-16
Table 2-15.	Set Descriptor-Device	2-17
Table 2-16.	Set Descriptor-Configuration	2-17
Table 2-17.	Set Descriptor-String	2-18
Table 2-18.	Set Configuration	2-20
Table 2-19.	Get Configuration	2-20
Table 2-20.	Set Interface (Actually, Set Alternate Setting #AS for Interface #IF)	2-21
Table 2-21.	Get Interface (Actually, Get Alternate Setting #AS for interface #IF)	2-22
Table 2-22.	Sync Frame	2-23
Table 2-23.	Firmware Download	2-24
Table 2-24.	Firmware Upload	2-24
Table 3-1.	Default Full-speed Alternate Settings	3-3
Table 3-2.	Default High-speed Alternate Settings	3-3
Table 3-3.	FX2 Device Characteristics, No EEPROM / Invalid EEPROM	3-4
Table 3-4.	“C0 Load” Format	3-5



*(List of Tables)*

Table 3-5.	“C2 Load” Format . . . . .	3-6
Table 3-6.	How the Default USB Device Handles EP0 Requests When RENUM=0 . . . .	3-10
Table 3-7.	Firmware Download . . . . .	3-11
Table 3-8.	Firmware Upload . . . . .	3-11
Table 4-1.	FX2 Interrupts . . . . .	4-1
Table 4-2.	IE Register — SFR 0xA8 . . . . .	4-2
Table 4-3.	IP Register — SFR 0xB8 . . . . .	4-3
Table 4-4.	EXIF Register — SFR 0x91 . . . . .	4-3
Table 4-5.	EICON Register — SFR 0xD8 . . . . .	4-4
Table 4-6.	EIE Register — SFR 0xE8 . . . . .	4-4
Table 4-7.	EIP Register — SFR 0xF8 . . . . .	4-5
Table 4-8.	Summary of Interrupt Compatibility . . . . .	4-5
Table 4-9.	Interrupt Flags, Enables, Priority Control, and Vectors . . . . .	4-7
Table 4-10.	Individual USB Interrupt Sources . . . . .	4-9
Table 4-11.	Endpoint Interrupts . . . . .	4-14
Table 4-12.	FX2 JUMP Instruction . . . . .	4-15
Table 4-13.	A Typical USB-Interrupt Jump Table . . . . .	4-16
Table 4-14.	Individual FIFO/GPIF Interrupt Sources . . . . .	4-19
Table 4-15.	FX2 JUMP Instruction . . . . .	4-20
Table 4-16.	A Typical FIFO/GPIF-Interrupt Jump Table . . . . .	4-21
Table 7-1.	Effects of Various Resets on FX2 Resources (“—” means “no change”) . . . . .	7-5
Table 8-1.	Maximum Packet Sizes for USB 1.1 and 2.0 . . . . .	8-2
Table 8-2.	Endpoint Configuration Registers . . . . .	8-3
Table 8-3.	Endpoint Buffers in RAM Space . . . . .	8-4
Table 8-4.	Registers that control EP0 and EP1 . . . . .	8-5
Table 8-5.	Registers that control EP2,EP4,EP6 and EP8 . . . . .	8-10
Table 8-6.	Isochronous IN Packets per Microframe, High-Speed Only . . . . .	8-11
Table 8-7.	Registers that control all endpoints . . . . .	8-13
Table 8-8.	Registers used to control the Setup Data Pointer . . . . .	8-18
Table 8-9.	Registers that control the Autopointers . . . . .	8-20
Table 9-1.	Registers Associated with Slave FIFO Hardware . . . . .	9-2
Table 9-2.	FIFO Selection via FIFOADR[1:0] . . . . .	9-8
Table 9-3.	Registers Associated with Slave FIFO Firmware . . . . .	9-19
Table 10-1.	Registers Associated with GPIF Hardware . . . . .	10-5
Table 10-2.	GPIF Pin Descriptions . . . . .	10-5



*(List of Tables)*

Table 10-3.	CTL[5:0] Output Modes . . . . .	10-7
Table 10-4.	Example GPIF Hardware Interconnect . . . . .	10-10
Table 10-5.	Control Outputs (CTLn) During the IDLE State . . . . .	10-14
Table 10-6.	Waveform Descriptor Addresses . . . . .	10-25
Table 10-7.	Waveform Descriptor 0 Structure . . . . .	10-25
Table 10-8.	Registers Associated with GPIF Firmware . . . . .	10-26
Table 11-1.	FX2 Speed Compared to Standard 8051 . . . . .	11-3
Table 11-2.	Comparison Between FX2 and Other 803x/805x Devices . . . . .	11-5
Table 11-3.	Differences between FX and DS80C320 Interrupts . . . . .	11-6
Table 11-4.	EZ-USB FX2 Interrupts . . . . .	11-9
Table 11-5.	FX2 Special Function Registers (SFR) . . . . .	11-10
Table 12-1.	Legend for Instruction Set Table . . . . .	12-1
Table 12-2.	FX2 Instruction Set . . . . .	12-2
Table 12-3.	Data Memory Stretch Values . . . . .	12-6
Table 12-4.	PSW Register - SFR 0xD0 . . . . .	12-8
Table 13-1.	Register Bits Which Select Port A Alternate Functions . . . . .	13-7
Table 13-2.	Port A Alternate-Function Configuration . . . . .	13-7
Table 13-3.	Register Bits Which Select Port B and Port D Alternate Functions . . . . .	13-8
Table 13-4.	Port B Alternate-Function Configuration . . . . .	13-8
Table 13-5.	Port D Alternate-Function Configuration . . . . .	13-8
Table 13-6.	Register Bits Which Select Port C Alternate Functions . . . . .	13-9
Table 13-7.	Port C Alternate-Function Configuration . . . . .	13-9
Table 13-8.	Register Bits Which Select Port E Alternate Functions . . . . .	13-10
Table 13-9.	Port E Alternate-Function Configuration . . . . .	13-10
Table 13-10.	IFCFG Selection of Port I/O Pin Functions . . . . .	13-11
Table 13-11.	Strap Boot EEPROM Address Lines to These Values . . . . .	13-17
Table 13-12.	Results of Power-On-Reset EEPROM Test . . . . .	13-18
Table 14-1.	Timer/Counter Implementation Comparison . . . . .	14-2
Table 14-2.	TMOD Register — SFR 0x89 . . . . .	14-4
Table 14-3.	TCON Register — SRF 0x88 . . . . .	14-5
Table 14-4.	CKCON (SFR 0x8E) Timer Rate Control Bits . . . . .	14-7
Table 14-5.	T2CON Register — SFR 0xC8 . . . . .	14-9
Table 14-6.	Timer 2 Mode Control Summary . . . . .	14-9
Table 14-7.	Serial Port Modes . . . . .	14-13
Table 14-8.	Serial Interface Implementation Comparison . . . . .	14-13



*(List of Tables)*

Table 14-9.	UART230 Register — Address 0xE608	14-14
Table 14-10.	Allowable Baud-Clock Combinations for Modes 1 and 3	14-14
Table 14-11.	SCON0 Register — SFR 98h	14-16
Table 14-12.	EICON (SFR 0xD8) SMOD1 Bit	14-16
Table 14-13.	PCON (SFR 0x87) SMOD0 Bit	14-16
Table 14-14.	SCON1 Register — SFR C0h	14-17
Table 14-15.	Timer 1 Reload Values for Common Serial Port Mode 1 Baud Rates	14-21
Table 14-16.	Timer 2 Reload Values for Common Serial Port Mode 1 Baud Rates	14-22
Table 15-1.	FX2 Special Function Registers (SFR)	15-3
Table 15-2.	SFR and FX2 Register File Correspondences	15-7
Table 15-3.	SFR Registers and External Ram Equivalent	15-12
Table 15-4.	CPU Clock Speeds	15-14
Table 15-5.	Internal FIFO/GPIF Clock Frequency	15-15
Table 15-6.	Port E Alternate Functions When GSTATE=1	15-16
Table 15-7.	Ports, GPIF, Slave FIFO Select	15-16
Table 15-8.	IFCFG Selection of Port I/O Pin Functions	15-17
Table 15-9.	FIFO Flag Pin Functions	15-19
Table 15-10.	FIFOADR1 FIFOADR2 Flag Correspondence	15-19
Table 15-11.	Endpoint Type Definitions	15-25
Table 15-12.	Endpoint Type Definitions	15-27
Table 15-13.	Endpoint Buffering Amounts	15-27
Table 15-14.	Interpretation of PF for IN Endpoints	15-38
Table 15-15.	IN Packets per Microframe	15-40
Table 15-16.	CTL[5:0] Output Modes	15-83
Table 15-17.	Control Outputs (CTLx) During the IDLE State	15-84
Table 15-18.	Control Outputs (CTLx) During the Flow State	15-89
Table 15-19.	Endpoint 2, 4, 6, 8 GPIF Flag Select Values	15-95
Table 15-20.	Registers Which Require a Synchronization Delay	15-103
Table A-1	Default USB Device Descriptor	1
Table A-2	Device Qualifier	2
Table A-3	USB Default Configuration Descriptor	2
Table A-4	USB Default Interface 0, Alternate Setting 0	3
Table A-5	USB Default Interface 0, Alternate Setting 1	3



*(List of Tables)*

Table A-6	Endpoint Descriptor (EP1 out) . . . . .	3
Table A-7	Endpoint Descriptor (EP1 in) . . . . .	4
Table A-8	Endpoint Descriptor (EP2) . . . . .	4
Table A-9	Endpoint Descriptor (EP4) . . . . .	4
Table A-10	Endpoint Descriptor (EP6) . . . . .	5
Table A-11	Endpoint Descriptor (EP8) . . . . .	5
Table A-12	Interface Descriptor (Alt. Setting 2) . . . . .	5
Table A-13	Endpoint Descriptor (EP1 out) . . . . .	6
Table A-14	Endpoint Descriptor (EP1 in) . . . . .	6
Table A-15	Endpoint Descriptor (EP2) . . . . .	6
Table A-16	Endpoint Descriptor (EP4) . . . . .	7
Table A-17	Endpoint Descriptor (EP6) . . . . .	7
Table A-18	Endpoint Descriptor (EP8) . . . . .	7
Table A-19	Interface Descriptor (Alt. Setting 3) . . . . .	8
Table A-20	Endpoint Descriptor (EP1 out) . . . . .	8
Table A-21	Endpoint Descriptor (EP1 in) . . . . .	8
Table A-22	Endpoint Descriptor (EP2) . . . . .	9
Table A-23	Endpoint Descriptor (EP4) . . . . .	9
Table A-24	Endpoint Descriptor (EP6) . . . . .	9
Table A-25	Endpoint Descriptor (EP8) . . . . .	10
Table B-1	Device Descriptor . . . . .	11
Table B-2	Device Qualifier . . . . .	12
Table B-3	Configuration Descriptor . . . . .	12
Table B-4	Interface Descriptor (Alt. Setting 0) . . . . .	13
Table B-5	Interface Descriptor (Alt. Setting 1) . . . . .	13
Table B-6	Endpoint Descriptor (EP1 out) . . . . .	13
Table B-7	Endpoint Descriptor (EP1 in) . . . . .	14
Table B-8	Endpoint Descriptor (EP2) . . . . .	14
Table B-9	Endpoint Descriptor (EP4) . . . . .	14
Table B-10	Endpoint Descriptor (EP6) . . . . .	15
Table B-11	Endpoint Descriptor (EP8) . . . . .	15
Table B-12	Interface Descriptor (Alt. Setting 2) . . . . .	15
Table B-13	Endpoint Descriptor (EP1 out) . . . . .	16
Table B-14	Endpoint Descriptor (EP1 in) . . . . .	16
Table B-15	Endpoint Descriptor (EP2) . . . . .	16



*(List of Tables)*

Table B-16	Endpoint Descriptor (EP4) . . . . .	17
Table B-17	Endpoint Descriptor (EP6) . . . . .	17
Table B-18	Endpoint Descriptor (EP8) . . . . .	17
Table B-19	Interface Descriptor (Alt. Setting 3) . . . . .	18
Table B-20	Endpoint Descriptor (EP1 out) . . . . .	18
Table B-21	Endpoint Descriptor (EP1 in) . . . . .	18
Table B-22	Endpoint Descriptor (EP2) . . . . .	19
Table B-23	Endpoint Descriptor (EP4) . . . . .	19
Table B-24	Endpoint Descriptor (EP6) . . . . .	19
Table B-25	Endpoint Descriptor (EP8) . . . . .	20



---

## Chapter 1 Introducing EZ-USB FX2

---

### 1.1 Introduction

---

The Universal Serial Bus (USB) has gained wide acceptance as the connection method of choice for low and medium speed PC peripherals. Equally successful in the Windows and Macintosh worlds, USB has delivered on its promises of easy attachment, an end to configuration hassles, and true plug-and-play operation.

The second generation of the USB specification, “USB 2.0”, extends the original specification to include:

- 480 Mbits/sec signaling rate, a 40x improvement over the USB 1.1 rate of 12 Mbits/sec.
- Full backward and forward compatibility with USB 1.1 devices and cables.
- A new hub architecture that can provide multiple 12 Mbits/sec downstream ports for USB 1.1 devices.

The Cypress Semiconductor EZ-USB FX2 (often abbreviated as “FX2” in this manual) is a single-chip USB 2.0 peripheral whose architecture is similar to that of the Cypress Semiconductor EZ-USB FX family. Although much of the FX architecture is preserved, certain elements have been redesigned to accommodate the higher data rates offered by USB 2.0.

This introductory chapter begins with a brief USB tutorial to put USB and FX2 terminology into context. The remainder of the chapter briefly outlines the FX2 architecture.

---

### 1.2 An Introduction to USB

---

Like a well-designed automobile or appliance, a USB peripheral’s outward simplicity hides internal complexity. There’s a lot going on “under the hood” of a USB device.

- A USB device can be plugged in anytime, even while the PC is turned on.
- When the PC detects that a USB device has been plugged in, it automatically interrogates the device to learn its capabilities and requirements. From this information, the PC auto-

matically loads the device's driver into the operating system. When the device is unplugged, the operating system automatically logs it off and unloads its driver.

- USB devices do not use DIP switches, jumpers, or configuration programs. There is never an IRQ, DMA, memory, or I/O conflict with a USB device.
- USB expansion hubs make the bus simultaneously available to dozens of devices.
- USB is fast enough for printers, hard disk drives, CD-quality audio, and scanners.
- With the introduction of the USB 2.0 Specification, USB supports three speeds:
  - *Low Speed* (1.5 Mbits/sec), suitable for mice, keyboards and joysticks.
  - *Full Speed* (12 Mbits/sec), for devices like modems, speakers and scanners.
  - *High Speed* (480 Mbits/sec), for devices like hard disk drives, CD-ROMs, video cameras, and high-resolution scanners.

The Cypress Semiconductor EZ-USB FX2 augments the EZ-USB family by supporting the high bandwidth offered by the USB 2.0 High Speed mode. The FX2 provides a highly-integrated solution for a USB peripheral device. Like all EZ-USB devices, the FX2 offers the following features:

- An integrated, high-performance CPU based on the industry-standard 8051 processor.
- A *soft* (RAM-based) architecture that allows unlimited configuration and upgrades.
- Full USB throughput. USB devices that use EZ-USB chips are not limited by number of endpoints, buffer sizes, or transfer speeds.
- Automatic handling of most of the USB protocol, which simplifies code and accelerates the USB learning curve.

---

## 1.3 The USB Specification

---

The *Universal Serial Bus Specification Version 2.0* is available on the Internet from the USB Implementers Forum, Inc., at <http://www.usb.org>. Published in April, 2000, the USB Specification is the work of a founding committee of seven industry heavyweights: Compaq, Hewlett-Packard, Lucent, Philips, Intel, Microsoft, and NEC. This impressive list of developers secures USB's position as the low- to high-speed PC connection method of the future.

A glance at the USB Specification makes it immediately apparent that USB is not nearly as simple as the older serial or parallel ports. The USB Specification uses new terms like *endpoint*, *isochronous*, and *enumeration*, and finds new uses for old terms like *configuration*, *interface*, and *interrupt*. Woven into the USB fabric is a software abstraction model that deals with things such as *pipes*. The USB Specification also contains information about such details as connector types and wire colors.



---

## 1.4 Host Is Master

---

This is a fundamental USB concept. There is exactly one master in a USB system: the host computer. **USB devices respond to host requests.** USB devices cannot send information among themselves, as they could if USB were a peer-to-peer topology.

However, there is one case where a USB device can initiate signaling without prompting from the host. After being put into a low-power “suspend” mode by the host, a device can signal a “remote wakeup”. This is the only case in which the USB device is the initiator; in all other cases, the host makes device requests and the device responds to them.

There’s an excellent reason for this host-centric model. The USB architects were keenly mindful of cost, and the best way to make low-cost peripherals is to put most of the “smarts” into the host side, the PC. If USB had been defined as peer-to-peer, every USB device would have required more intelligence, raising cost.

---

## 1.5 USB Direction

---

Because the host is always the bus master, it’s easy to remember USB direction: OUT means from the host to the device, and IN means from the device to the host. FX2 nomenclature uses this naming convention. For example, an endpoint that sends data to the host is an IN endpoint. This can be confusing at first, because the FX2 *sends* data to the host by loading an IN endpoint buffer. Likewise, the FX2 *receives* host data from an OUT endpoint buffer.

---

## 1.6 Tokens and PIDs

---

In this manual, you’ll read statements such as: “When the host sends an IN token...,” or “The device responds with an ACK”. What do these terms mean?

A USB transaction consists of data packets identified by special codes called Packet IDs or PIDs. A PID signifies what kind of packet is being transmitted. There are four PID types, shown in Table 1-1.

Table 1-1. USB PIDS

PID Type	PID Name
Token	IN, OUT, SOF, SETUP
Data	DATA0, DATA1, <b>DATA2, MDATA</b>
Handshake	ACK, NAK, STALL, <b>NYET</b>
Special	PRE, <b>ERR, SPLIT, PING</b>

Bold type indicates PIDs introduced with USB 2.0

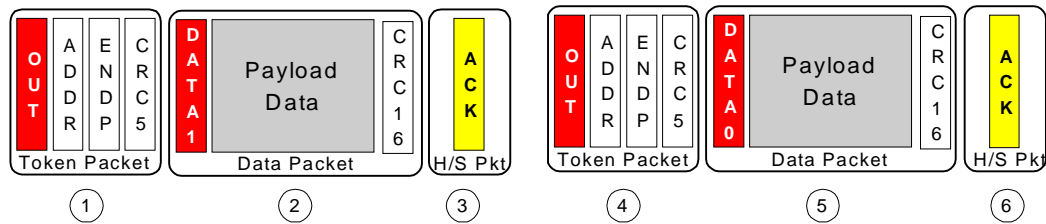

Figure 1-1. USB Packets

Figure 1-1 illustrates a USB OUT transfer. Host traffic is shown in solid shading, while device traffic is shown crosshatched. Packet 1 is an OUT token, indicated by the OUT PID. The OUT token signifies that data from the host is about to be transmitted over the bus. Packet 2 contains data, as indicated by the DATA1 PID. Packet 3 is a handshake packet, sent by the device using the ACK (acknowledge) PID to signify to the host that the device received the data error-free.

Continuing with Figure 1-1, a second transaction begins with another OUT token 4, followed by more data 5, this time using the DATA0 PID. Finally, the device again indicates success by transmitting the ACK PID in a handshake packet 6.

When operating at full speed, every OUT transfer sends the OUT data, even when the device is busy and can't accept the data. When operating at high speed, this slightly wasteful use of USB bandwidth is remedied by using the new "Ping" PID. The host first sends a short PING token to an OUT endpoint, asking if there is room for OUT data in the peripheral device. Only when the PING is answered by an ACK does the host send the OUT token and data.

There are *two* DATA PIDs (DATA0 and DATA1) in Figure 1-1 because the USB architects took error correction very seriously. As mentioned previously, the ACK handshake is an indication to the host that the peripheral received data without error (the CRC portion of the packet is used to detect errors). But what if the handshake packet itself is garbled in transmission? To detect this, each side (host and device) maintains a *data toggle* bit, which is toggled between data packet transfers. The state of this internal toggle bit is compared with the PID that arrives with the data, either DATA0 or DATA1. When sending data, the host or device sends alternating DATA0-DATA1 PIDs. By comparing the received Data PID with the state of its own internal toggle bit, the receiver can detect a corrupted handshake packet.

SETUP tokens are unique to CONTROL transfers. They preface eight bytes of data from which the peripheral decodes host Device Requests.

At full speed, SOF (Start of Frame) tokens occur once per millisecond. At high speed, each frame contains eight SOF tokens, each denoting a 125-microsecond *microframe*.

Four handshake PIDs indicate the status of a USB transfer:

- ACK ("Acknowledge") means *success*; the data was received error-free.
- NAK ("Negative Acknowledge") means "busy, try again." It's tempting to assume that NAK means "error," but it doesn't; a USB device indicates an error by *not responding*.

- STALL means that something unforeseen went wrong (probably as a result of miscommunication or lack of cooperation between the host and device software). A device sends the STALL handshake to indicate that it doesn't understand a device request, that something went wrong on the peripheral end, or that the host tried to access a resource that wasn't there. It's like HALT, but better, because USB provides a way to recover from a stall.
- NYET ("Not Yet") has the same meaning as ACK — the data was received error-free — but also indicates that the endpoint is not yet ready to receive *another* OUT transfer. NYET PIDs occur only in high speed mode.

A PRE (Preamble) PID precedes a low-speed (1.5 Mbits/sec) USB transmission. The FX2 supports full-speed (12 Mbits/sec) and high-speed (480 Mbits/sec) USB transfers only.

---

### **1.6.1 Receiving Data from the Host**

To send data to a USB peripheral, the host issues an OUT token followed by the data. If the peripheral has space for the data and accepts it without error, it returns an ACK to the host. If it is busy, it sends a NAK. If it finds an error, it sends back nothing. For the latter two cases, the host re-sends the data at a later time.

---

### **1.6.2 Sending Data to the Host**

**A USB device never spontaneously sends data to the host.** Either FX2 firmware or external logic can load data into an FX2 endpoint buffer and 'arm' it for transfer at any time. However, the data is not transmitted to the host until the host issues an IN request to the FX2 endpoint. If the host never sends the IN token, the data remains in the FX2 endpoint buffer indefinitely.

---

## **1.7 USB Frames**

---

The USB host provides a time base to all USB devices by transmitting an SOF ("Start of Frame") packet every millisecond. SOF packets include an 11-bit number which increments once per frame; the current frame number [0-2047] may be read from internal FX2 registers at any time.

At high speed (480 Mbits/sec), each one-millisecond frame is divided into eight 125-microsecond *microframes*, each of which is preceded by an SOF packet. The frame number still increments only once per millisecond, so each of those SOF packets contains the same frame number. To keep track of the current microframe number [0-7], the FX2 provides a readable microframe counter.

The FX2 can generate an interrupt request whenever it receives an SOF (once every millisecond at full speed, or once every 125 microseconds at high speed). This SOF interrupt can be used, for example, to service isochronous endpoint data.

## 1.8 USB Transfer Types

USB defines four transfer types. These match the requirements of different data types delivered over the bus.

### 1.8.1 Bulk Transfers

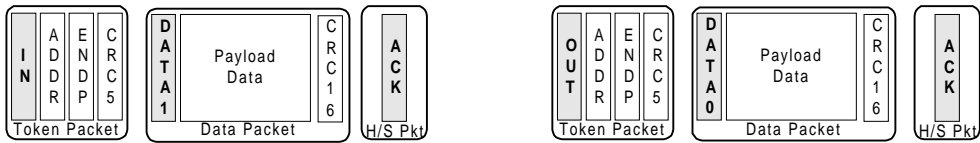

Figure 1-2. Two Bulk Transfers, IN and OUT

Bulk data is *bursty*, traveling in packets of 8, 16, 32 or 64 bytes at full speed or 512 bytes at high speed. Bulk data has guaranteed accuracy, due to an automatic retry mechanism for erroneous data. The host schedules bulk packets when there is available bus time. Bulk transfers are typically used for printer, scanner, or modem data. Bulk data has built-in flow control provided by handshake packets.

### 1.8.2 Interrupt Transfers

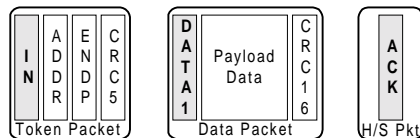

Figure 1-3. An Interrupt Transfer

Interrupt data is like bulk data; it can have packet sizes of 1 through 64 bytes at full speed or up to 1024 bytes at high speed. Interrupt endpoints have an associated polling interval that ensures they will be polled (receive an IN token) by the host on a regular basis.

### 1.8.3 Isochronous Transfers

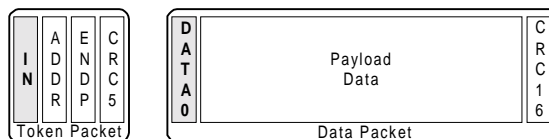

Figure 1-4. An Isochronous Transfer

Isochronous data is time-critical and used to *stream* data like audio and video. An isochronous packet may contain up to 1023 bytes at full speed, or up to 1024 bytes at high speed.

Time of delivery is the most important requirement for isochronous data. In every USB frame, a certain amount of USB bandwidth is allocated to isochronous transfers. To lighten the overhead, isochronous transfers have no handshake (ACK/NAK/STALL/NYET), and no retries; error detection is limited to a 16-bit CRC.

Isochronous transfers do not use the data-toggle mechanism. Full-speed isochronous data uses only the DATA0 PID; high-speed isochronous data uses DATA0, DATA1, DATA2 and MDATA.

In full-speed mode, only one isochronous packet can be transferred per endpoint, per frame. In high-speed mode, up to three isochronous packets can be transferred per endpoint, per micro-frame.

### 1.8.4 Control Transfers

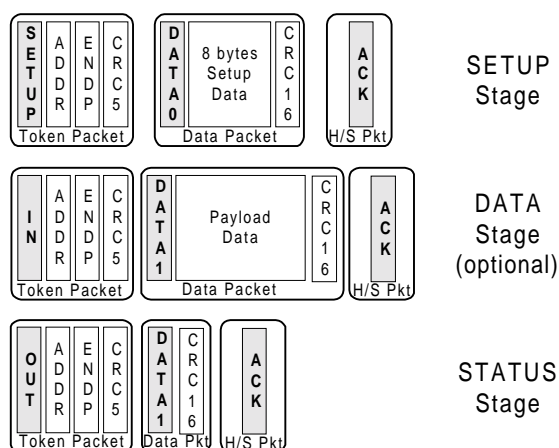

Figure 1-5. A Control Transfer

Control transfers configure and send commands to a device. Because they're so important, they employ the most extensive USB error checking. The host reserves a portion of each USB frame for Control transfers.

Control transfers consist of two or three stages. The SETUP stage contains eight bytes of USB CONTROL data. An optional DATA stage contains more data, if required. The STATUS (or "handshake") stage allows the device to indicate successful completion of a CONTROL operation.

---

## 1.9 Enumeration

---

Your computer is ON. You plug in a USB device, and the Windows™ cursor switches to an hour-glass and then back to a cursor. Magically, your device is connected and its Windows™ driver is loaded! Anyone who has installed a sound card into a PC and has had to configure countless jumpers, drivers, and IO/Interrupt/DMA settings knows that a USB connection is miraculous. We've all *heard* about Plug and Play, but USB delivers the real thing.

How does all this happen automatically? Inside every USB device is a table of *descriptors*. This table is the sum total of the device's requirements and capabilities. When you plug into USB, the host goes through a *sign-on* sequence:

1. The host sends a *Get Descriptor-Device* request to address zero (all USB devices must respond to address zero when first attached).
2. The device responds to the request by sending ID data back to the host to identify itself.
3. The host sends a *Set Address* request, which assigns a unique address to the just-attached device so it may be distinguished from the other devices connected to the bus.
4. The host sends more *Get Descriptor* requests, asking for additional device information. From this, it learns everything else about the device: number of endpoints, power requirements, required bus bandwidth, what driver to load, etc.

This sign-on process is called *Enumeration*.

---

### 1.9.1 Full-Speed / High-Speed Detection

The USB 2.0 Specification requires that high-speed (480 Mbit/sec) devices must also be capable of enumerating at full-speed (12 Mbit/s). In fact, all high-speed devices begin the enumeration process in full-speed mode; devices switch to high-speed operation only after the host and device have *agreed* to operate at high speed. The high-speed negotiation process occurs during USB reset, via the "Chirp" protocol described in Chapter 7 of the USB 2.0 Specification.

When connected to a full-speed host, the FX2 will enumerate as a full-speed device. When connected to a high-speed host, the FX2 automatically switches to high-speed mode.

## 1.10 The Serial Interface Engine (SIE)

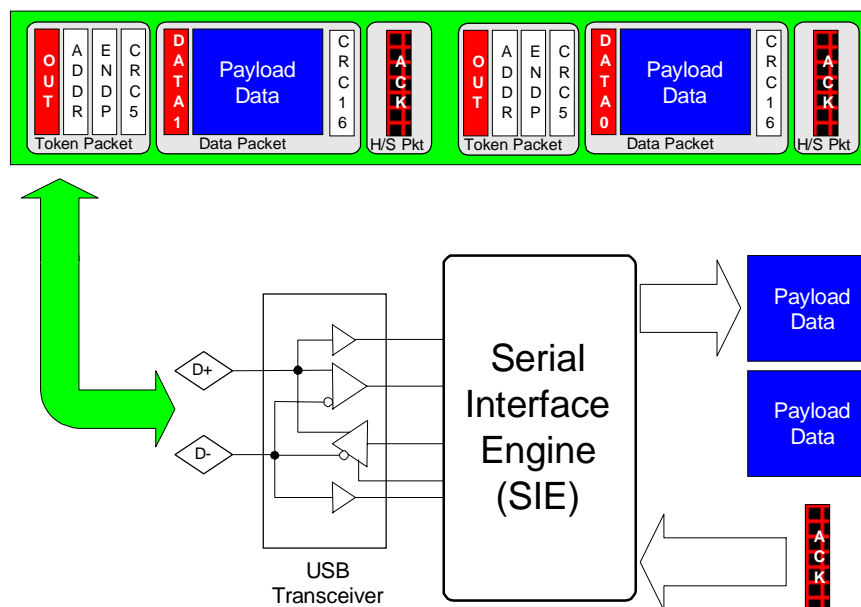

Figure 1-6. What the SIE Does

Every USB device has a Serial Interface Engine (SIE) which connects to the USB data lines (D+ and D-) and delivers data to and from the USB device. Figure 1-6 illustrates the SIE's role: it decodes the packet PIDs, performs error checking on the data using the transmitted CRC bits, and delivers payload data to the USB device.

Bulk transfers are *asynchronous*, meaning that they include a flow control mechanism using ACK and NAK handshake PIDs. The SIE indicates *busy* to the host by sending a NAK handshake packet. When the USB device has successfully transferred the data, it commands the SIE to send an ACK handshake packet, indicating success. If the SIE encounters an error in the data, it automatically indicates *no response* instead of supplying a handshake PID. This instructs the host to retransmit the data at a later time.

To send data to the host, the SIE accepts bytes and control signals from the USB device, formats it for USB transfer, and sends it over D+ and D-. Because USB uses a self-clocking data format (NRZI), the SIE also inserts bits at appropriate places in the bit stream to guarantee a certain number of transitions in the serial data. This is called "bit stuffing," and is handled automatically by the FX2's SIE.

One of the most important features of the FX2 (and the other EZ-USB chips) family is that its configuration is *soft*. Instead of requiring ROM or other fixed memory, it contains internal program/data

RAM which can be loaded over the USB. This makes modifications, specification revisions, and updates a snap.

The FX2's "smart" SIE performs much more than the basic functions shown in Figure1-6; it can perform a full enumeration by itself, which allows the FX2 to connect as a USB device and download code into its RAM while its CPU is held in reset. This added SIE functionality is also made available to the FX2 programmer, to make development easier and save code and processing time.

---

## **1.11 ReNumeration™**

---

Because the FX2's configuration is *soft*, one chip can take on the identities of multiple distinct USB devices.

When first plugged into USB, the FX2 enumerates automatically and downloads firmware and USB descriptor tables over the USB cable. Next, the FX2 enumerates again, this time as a device defined by the downloaded information. This patented two-step process, called ReNumeration™, happens instantly when the device is plugged in, with no hint that the initial download step has occurred.

Alternately, FX2 can also load its firmware from an external EEPROM.

*Chapter 3, "Enumeration and ReNumeration™"* describes these processes in detail.



## 1.12 EZ-USB FX2 Architecture

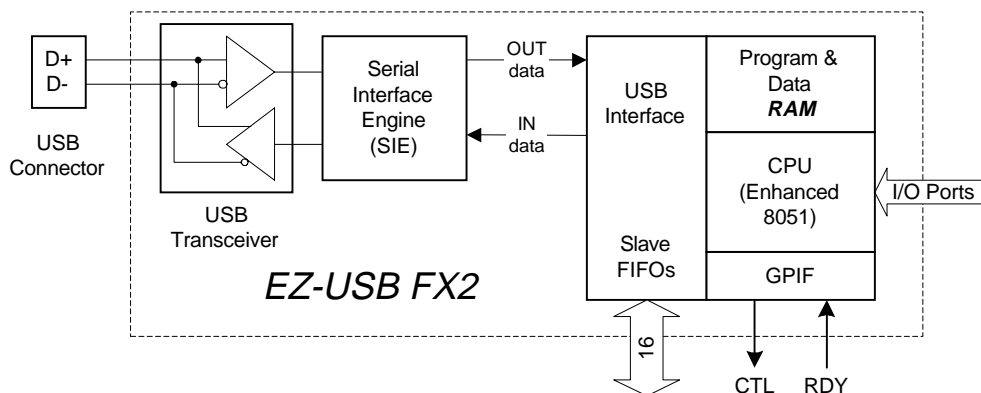

Figure 1-7. FX2 56-pin Package Simplified Block Diagram

The FX2 packs all the intelligence required by a USB peripheral interface into a compact integrated circuit. As Figure 1-7 illustrates, an integrated USB transceiver connects to the USB bus pins D+ and D-. A Serial Interface Engine (SIE) decodes and encodes the serial data and performs error correction, bit stuffing, and the other signaling-level tasks required by USB. Ultimately, the SIE transfers parallel data to and from the USB interface.

The FX2 SIE operates at Full Speed (12 Mbits/sec) and High Speed (480 Mbits/sec) rates. To accommodate the increased bandwidth of USB 2.0, the FX2 endpoint FIFOs and slave FIFOs (which interface to external logic or processors) are unified to eliminate internal data transfer times.

The CPU is an enhanced 8051 with fast execution time and added features. It uses internal RAM for program and data storage.

The role of the CPU in a typical FX2-based USB peripheral is twofold:

- It implements the high-level USB protocol by servicing host requests over the control endpoint (endpoint zero)
- It is available for general-purpose system use

The high-level USB protocol is not bandwidth-critical, so the FX2's CPU is well-suited for handling host requests over the control endpoint. However, the data rates offered by USB 2.0 are too high for the CPU to process the USB data directly. For this reason, the CPU is not usually in the high-bandwidth data path between endpoint FIFOs and the external interface. Instead, *the CPU simply configures the interface, then "gets out of the way" while the unified FX2 FIFOs move the data directly between the USB and the external interface.*

The FIFOs can be controlled by an external master, which either supplies a clock and clock-enable signals to operate synchronously, or strobe signals to operate asynchronously.

Alternately, the FIFOs can be controlled by an internal FX2 timing generator called the General Programmable Interface (GPIF). The GPIF serves as an *internal* master, interfacing directly to the FIFOs and generating user-programmed control signals for the interface to external logic. Additionally, the GPIF can be made to wait for external events by sampling external signals on its RDY pins. The GPIF runs much faster than the FIFO data rate to give good programmable resolution for the timing signals. It can be clocked from either the internal FX2 clock or an externally supplied clock.

The FX2's CPU is rich in features. Up to five I/O ports are available, as well as two UARTs, three counter/timers, and an extensive interrupt system. It runs at a clock rate of up to 48 MHz and uses four clocks per instruction cycle instead of the twelve required by a standard 8051.

The FX2 chip family uses an enhanced SIE/USB interface which simplifies FX2 code by implementing much of the USB protocol. In fact, the FX2 can function as a full USB device even without firmware.

Like all EZ-USB family chips, FX2 operates at 3.3V. This simplifies the design of bus-powered USB devices, since the 5V power available at the USB connector (which the USB Specification allows to be as low as 4.4V) can drive a 3.3V regulator to deliver clean, isolated power to the FX2 chip.

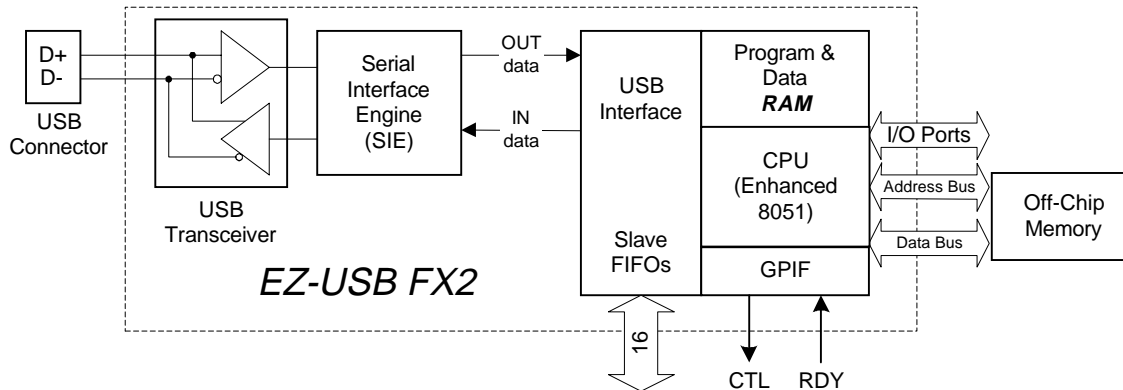

Figure 1-8. FX2 128-pin Package Simplified Block Diagram

FX2 is available in a 128-pin package which brings out the 8051 address bus, data bus, and control signals to allow connection of external memory and/or memory-mapped I/O. Figure e1-8 is a block diagram for this package; *Chapter 5, "Memory"*, gives full details of the external-memory interface.

---

## 1.13 FX2 Feature Summary

---

FX2 includes the following features:

- On-chip 480 Mbits/sec transceiver, PLL and SIE—the entire USB 2.0 physical layer (PHY).
- Double-, triple- and quad-buffered endpoint FIFOs accommodate the 480 Mbits/sec USB 2.0 data rate.
- Built-in, enhanced 8051 running at up to 48 MHz.
  - Fully featured: 256 bytes of register RAM, two UARTs, three timers, two data pointers.
  - Fast: four clocks (83.3 nanoseconds at 48 MHz) per instruction cycle.
  - SFR access to control registers (including I/O ports) that require high speed.
  - USB-vectored interrupts for low ISR latency.
  - Used for USB housekeeping and control, not to move high speed data.
- “Soft” operation—USB firmware can be downloaded over USB, eliminating the need for hard-coded memory.
- Four interface FIFOs that can be internally or externally clocked. The endpoint and interface FIFOs are unified to eliminate data transfer time between USB and external logic.
- General Programmable Interface (GPIF), a microcoded state machine which serves as a timing master for ‘glueless’ interface to the FX2 FIFOs.

FX2 is a single-chip USB 2.0 peripheral solution. Unlike designs that use an external PHY, the FX2 integrates everything on one chip, eliminating costly high pin-count packages and the need to route high-speed signals between chips.

---

## 1.14 FX2 Integrated Microprocessor

---

The FX2’s CPU uses on-chip RAM as program and data memory. *Chapter 5, “Memory”*, describes the various internal/external memory options.

The CPU communicates with the SIE using a set of registers occupying on-chip RAM addresses 0xE600-0xE6FF. These registers are grouped and described by function in individual chapters of this reference manual and summarized in register order in *Chapter 15, “Registers”*.

The CPU has two duties. First, it participates in the protocol defined in the *Universal Serial Bus Specification Version 2.0, “Chapter 9, USB Device Framework.”* Thanks to the FX2’s “smart” SIE,

the firmware associated with the USB protocol is simplified, leaving code space and bandwidth available for the CPU's primary duty—to help implement your device. On the device side, abundant input/output resources are available, including I/O ports, UARTs, and an I<sup>2</sup>C-compatible bus master controller. These resources are described in *Chapter 13, "Input/Output"*, and *Chapter 14, "Timers/Counters and Serial Interface"*.

It's important to recognize that the FX2 architecture is such that the CPU sets up and controls data transfers, but it normally does not **participate** in high bandwidth transfers. It is not in the data path; instead, the large data FIFOs that handle endpoint data connect directly to outside interfaces. To make the interface versatile, a programmable timing generator (GPIF, General Programmable Interface) can create user-programmed waveforms for high bandwidth transfers between the internal FIFOs and external logic.

FX2 adds eight interrupt sources to the standard 8051 interrupt system:

- INT2: USB Interrupt
- INT3: I<sup>2</sup>C-Compatible Bus Interrupt
- INT4: FIFO/GPIF Interrupt
- INT4: External Interrupt 4
- INT5: External Interrupt 5
- INT6: External Interrupt 6
- UART1: UART1 Interrupt
- WAKEUP: USB Resume Interrupt

The FX2 provides 27 individual USB-interrupt sources which share the INT2 interrupt, and 14 individual FIFO/GPIF-interrupt sources which share the INT4 interrupt. To save the code and processing time which normally would be required to identify an individual interrupt source, the FX2 provides a second level of interrupt vectoring called *Autovectoring*. Each INT2 and INT4 interrupt source has its own autovector, so when an interrupt requires service, the proper ISR (interrupt service routine) is automatically invoked. *Chapter 4, "Interrupts"* describes the FX2 interrupt system.

## 1.15 FX2 Block Diagram

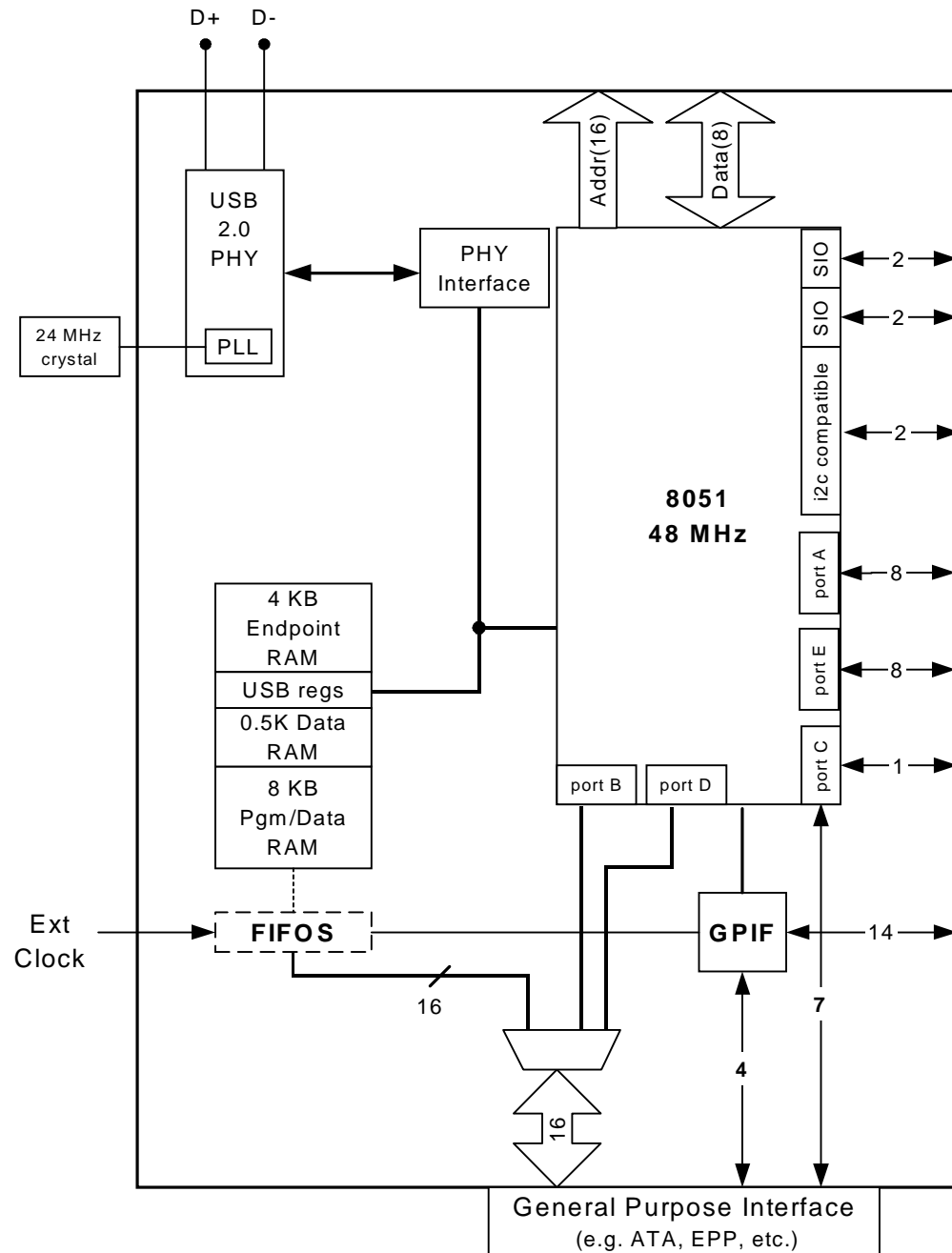

Figure 1-9. FX2 Block Diagram

---

## 1.16 Packages

---

FX2 is available in three packages:

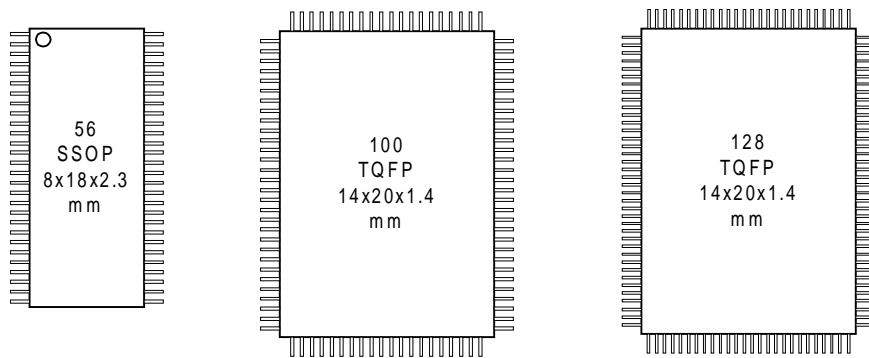

Figure 1-10. 56-pin, 100-pin, and 128-pin FX2 Packages

---

### 1.16.1 56-Pin Package

Twenty-four general-purpose I/O pins (ports A, B, and D) are available. Sixteen of these I/O pins can be configured as the 16-bit data interface to the FX2's internal high-speed 16-bit FIFOs, which can be used to implement low cost, high-performance interfaces such as ATAPI, UTOPIA, EPP, etc. The 56-pin package has the following:

- Three 8-bit I/O ports: PORTA, PORTB, and PORTD
- I<sup>2</sup>C-compatible bus
- An 8- or 16-bit General Programmable Interface (GPIF) multiplexed onto PORTB and PORTD, with five non-multiplexed control signals
- Four 8- or 16-bit Slave FIFOs, with five non-multiplexed control signals and four or five control signals multiplexed with PORTA

---

### 1.16.2 100-Pin Package

The 100-pin package adds functionality to the 56-pin package:

- Two additional 8-bit I/O ports: PORTC and PORTE
- Seven additional GPIF Control (CTL) and Ready (RDY) signals
- Nine non-multiplexed peripheral signals (two UARTs, three timer inputs, INT4, and  $\overline{\text{INT5}}$ )
- Eight additional control signals multiplexed onto PORTE
- Nine GPIF address lines, multiplexed onto PORTC (eight) and PORTE (one)
- $\overline{\text{RD}}$  and  $\overline{\text{WR}}$  signals which may be used as read and write strobes for PORTC

---

### 1.16.3 128-Pin Package

The 128-pin package adds the 8051 address and data buses and control signals. The  $\overline{\text{RD}}$ ,  $\overline{\text{PSEN}}$ , and  $\overline{\text{WR}}$  strobes are standard 8051 control strobes, serving as read/write strobes for external memory attached to the 8051 address and data buses. The FX2 encodes the  $\overline{\text{CS}}$  and  $\overline{\text{OE}}$  signals to automatically exclude external access to memory spaces which exist on-chip, and optionally to combine off-chip data- and code-memory read accesses. The 128-pin package adds the following:

- 16-bit 8051 address bus
- 8-bit 8051 data bus
- Address/data bus control signals

---

### 1.16.4 Signals Available in the Three Packages

Three interface modes are available: Ports, GPIF Master, and Slave FIFO.

Figure 1-11 shows a logical diagram of the signals available in the three packages. The signals on the left edge of the diagram are common to all interface modes, while the signals on the right are specific to each mode. The interface mode is software-selectable via an internal mode register.

In “Ports” mode, all the I/O pins are general-purpose I/O ports.

“GPIF master” mode uses the PORTB and PORTD pins as a 16-bit data interface to the four FX2 endpoint FIFOs EP2, EP4, EP6 and EP8. In this “master” mode, the FX2 FIFOs are controlled by the internal GPIF, a programmable waveform generator that responds to FIFO status flags, drives timing signals using its CTL outputs, and waits for external conditions to be true on its RDY inputs. Note that only a subset of the GPIF signals (CTL0-2, RDY0-1) is available in the 56-pin package, while the full set (CTL0-5, RDY0-5) is available in the 100- and 128-pin packages.

In the “Slave FIFO” mode, external logic or an external processor interfaces directly to the FX2 endpoint FIFOs. In this mode, the GPIF is not active, since external logic has direct FIFO control. Therefore, the basic FIFO signals (flags, selectors, strobes) are brought out on FX2 pins. The external master can be asynchronous or synchronous, and it may supply its own independent clock to the FX2 interface.

The 100-pin package includes all the functionality of the 56-pin package, and brings out the two additional I/O ports PORTC and PORTE as well as all the USART, Timer, Interrupt, and GPIF signals. The RD and WR pins function as port strobes in the 100-pin package, and as expansion memory strobes in the 128-pin package.

The 128-pin package adds 28 pins to the 100-pin package to bring out the full 8051 expansion memory bus. This allows for the connection of external memory for applications that run at power-on and before connection to USB. The 128-pin package also provides the foundation for the Cypress FX2 Development Kit boards, in which code is developed using a debug monitor that runs in external RAM.



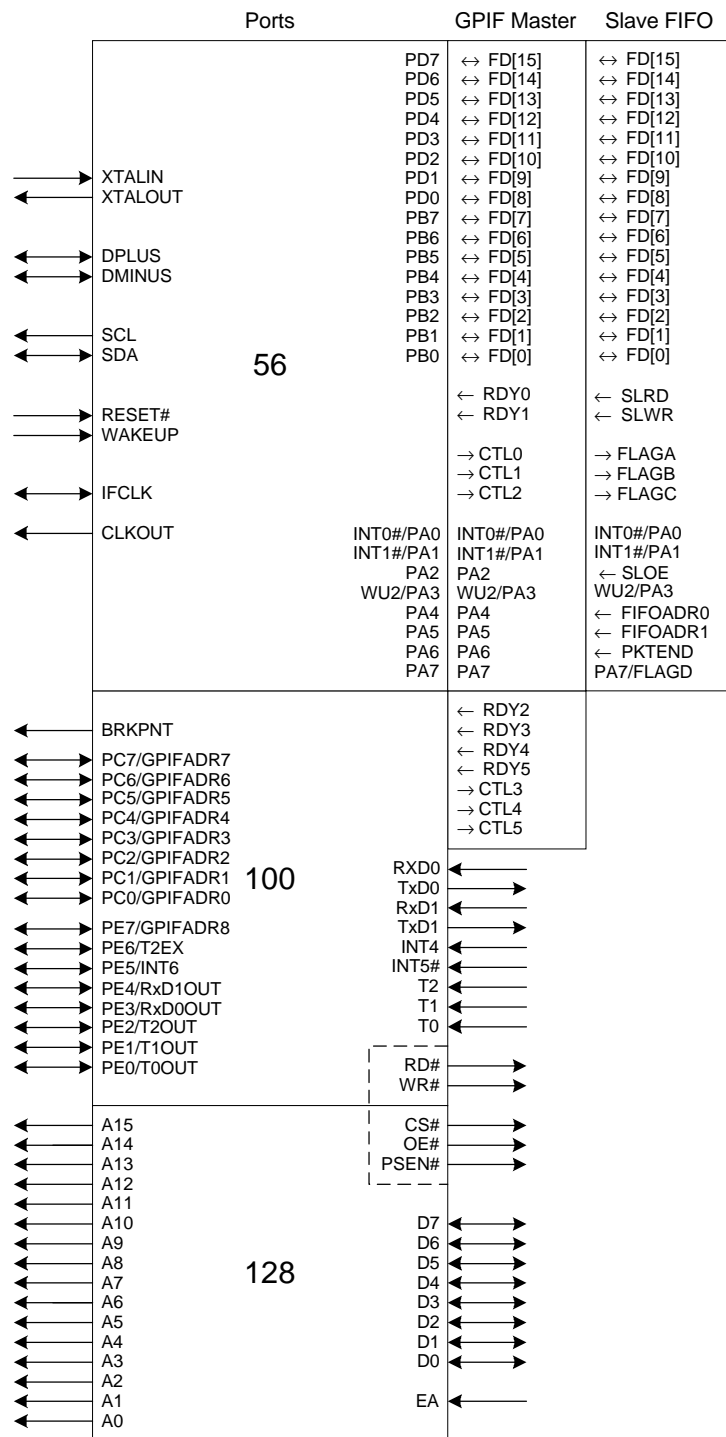

Figure 1-11. Signals for the Three FX2 Package Types

## 1.17 Package Diagrams

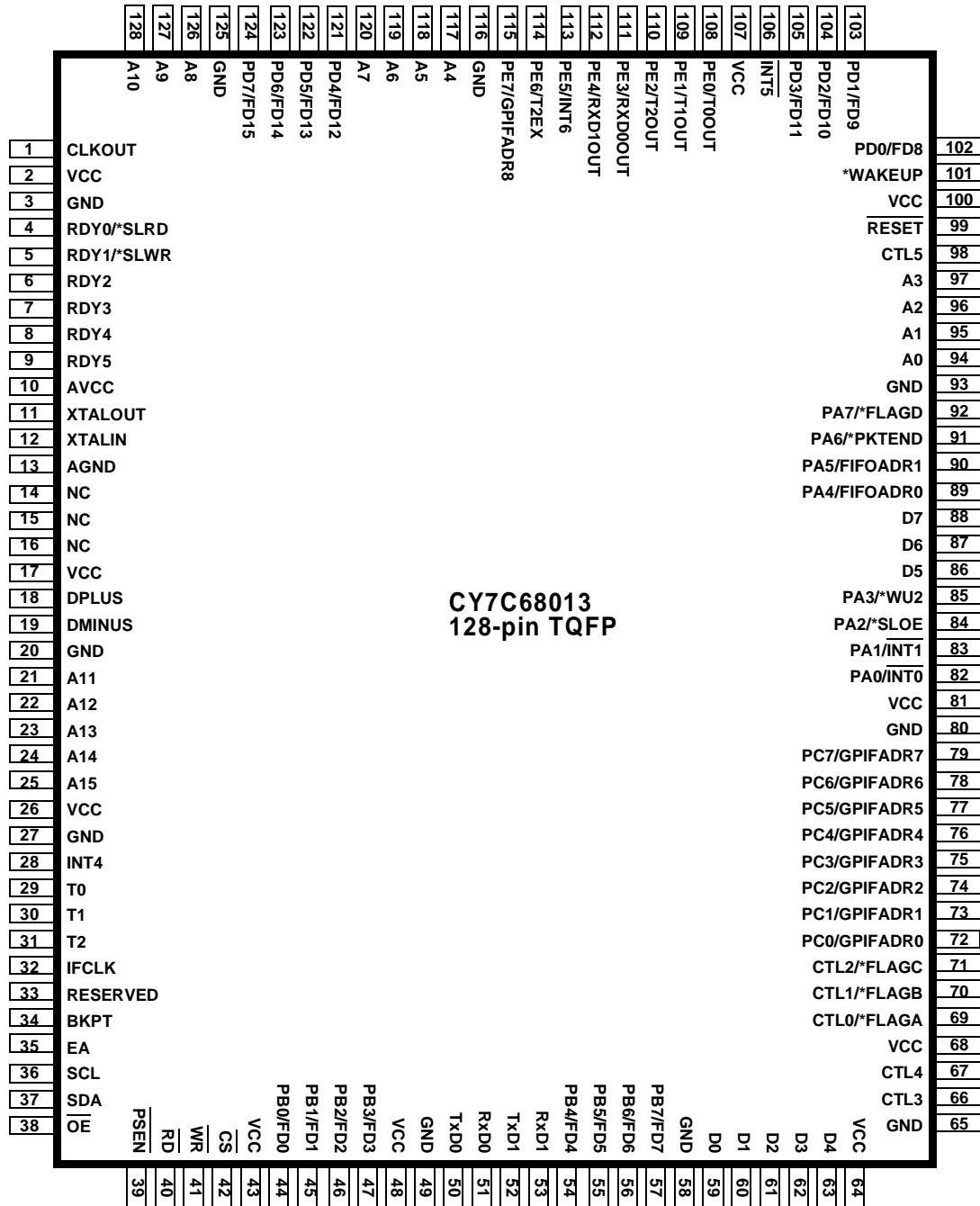

Figure 1-12. CY7C68013-128 TQFP Pin Assignment



1	PD5/FD13	PD4/FD12	56
2	PD6/FD14	PD3/FD11	55
3	PD7/FD15	PD2/FD10	54
4	GND	PD1/FD9	53
5	CLKOUT	PD0/FD8	52
6	VCC	*WAKEUP	51
7	GND	VCC	50
8	RDY0/*SLRD	RESET	49
9	RDY1/*SLWR	GND	48
10	AVCC	PA7/*FLAGD	47
11	XTALOUT	PA6/PKTEND	46
12	XTALIN	PA5/FIFOADR1	45
13	AGND	PA4/FIFOADR0	44
14	VCC	PA3/*WU2	43
15	DPLUS	PA2/*SLOE	42
16	DMINUS	PA1/INT1	41
17	GND	PA0/INT0	40
18	VCC	VCC	39
19	GND	CTL2/*FLAGC	38
20	IFCLK	CTL1/*FLAGB	37
21	RESERVED	CTL0/*FLAGA	36
22	SCL	<b>CY7C68013</b> GND	35
23	SDA	<b>56-pin SSOP</b> VCC	34
24	VCC	GND	33
25	PB0/FD0	PB7/FD7	32
26	PB1/FD1	PB6/FD6	31
27	PB2/FD2	PB5/FD5	30
28	PB3/FD3	PB4/FD4	29

Figure 1-14. CY7C68013-56 SSOP Pin Assignment

## 1.18 FX2 Endpoint Buffers

The USB Specification defines an endpoint as a source or sink of data. Since USB is a serial bus, a device endpoint is actually a FIFO which sequentially empties or fills with USB data bytes. The host selects a device endpoint by sending a 4-bit address and a direction bit. Therefore, USB can uniquely address 32 endpoints, IN0 through IN15 and OUT0 through OUT15.

From the FX2's point of view, an endpoint is a buffer full of bytes received or held for transmission over the bus. The FX2 reads host data from an OUT endpoint buffer, and writes data for transmission to the host to an IN endpoint buffer.

FX2 contains three 64-byte endpoint buffers, plus 4 Kilobytes of buffer space that can be configured various ways, as indicated by Figure 1-15. The three 64-byte buffers are common to all configurations.

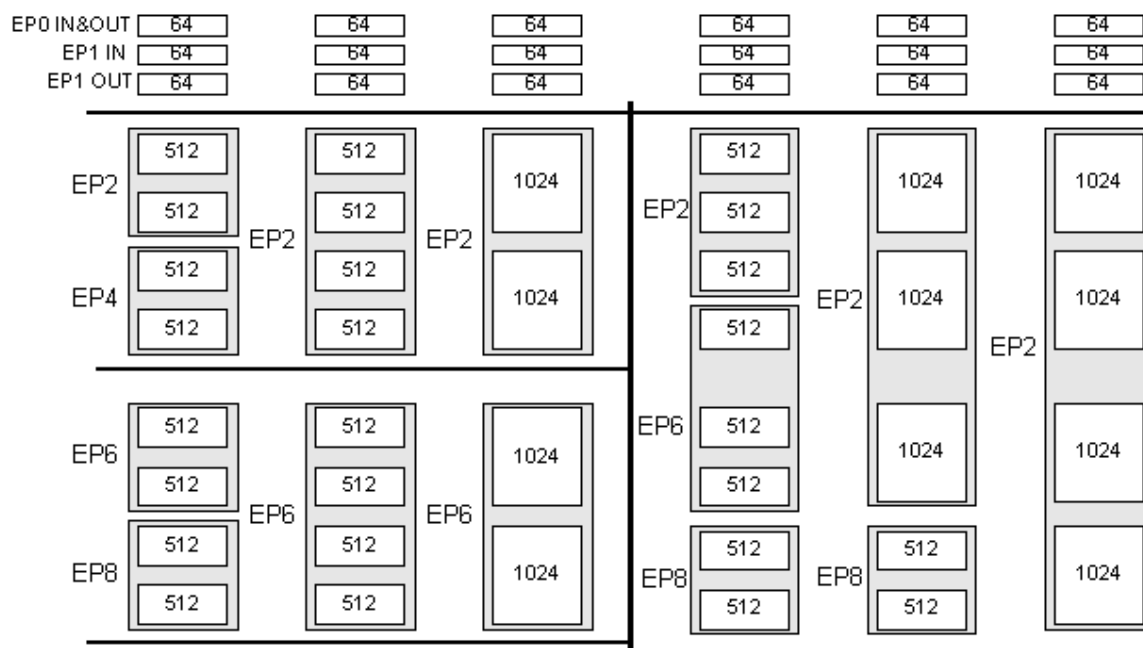

Figure 1-15. FX2 Endpoint Buffers

The three 64-byte buffers are designated EP0, EP1IN and EP1OUT. EP0 is the default CONTROL endpoint, a bidirectional endpoint that uses a single 64-byte buffer for both IN and OUT data. FX2 firmware reads or fills the EP0 buffer when the (optional) data stage of a CONTROL transfer is required.



The eight SETUP bytes in a CONTROL transfer do not appear in the 64-byte EP0 endpoint buffer. Instead, to simplify programming, the FX2 automatically stores the eight SETUP bytes in a separate buffer (SETUPDAT, at 0xE6B8-0xE6BF).

EP1IN and EP1OUT use separate 64 byte buffers. FX2 firmware can configure these endpoints as BULK, INTERRUPT or ISOCHRONOUS. These endpoints, as well as EP0, are accessible only by FX2 firmware. This is in contrast to the large endpoint buffers EP2, EP4, EP6 and EP8, which are designed to move high bandwidth data directly on and off chip without firmware intervention.

Endpoints 2, 4, 6 and 8 are the large, high bandwidth, data moving endpoints. They can be configured various ways to suit bandwidth requirements. The shaded boxes in Figure 1-15 enclose the buffers to indicate double, triple, or quad buffering. Double buffering means that one packet of data can be filling or emptying with USB data while another packet (from the same endpoint) is being serviced by external interface logic. Triple buffering adds a third packet buffer to the pool, which can be used by either side (USB or interface) as needed. Quad buffering adds a fourth packet buffer. Multiple buffering can significantly improve USB bandwidth performance when the data supplying and consuming rates are similar, but bursty; it smooths out the bursts, reducing or eliminating the need for one side to wait for the other.

Endpoints 2, 4, 6 and 8 can be configured using the choices shown in Table1-2.

Table 1-2. Endpoint 2, 4, 6, and 8 Configuration Choices

Characteristic	Choices
Direction	IN, OUT
Type	Bulk, Interrupt, Isochronous
Buffering	Double, triple, quad

When the FX2 operates at full speed (12 Mbits/sec), some or all of the endpoint buffer bytes shown in Figure 1-15 may be employed, depending on endpoint type. *Regardless of the physical buffer size, the endpoint buffer accommodates only one full-speed packet.*

For example, if EP2 is used as a full-speed BULK endpoint, the maximum number of bytes (maxPacketSize) it can accommodate is 64, even though the physical buffer size is 512 or 1024 bytes (it makes sense, therefore, to configure full-speed BULK endpoints as 512 bytes rather than 1024, so that fewer unused bytes are wasted). An ISOCHRONOUS full speed endpoint, on the other hand, could fully use either a 512- or 1024-byte buffer.

---

## 1.19 External FIFO Interface

---

The large data FIFOs (endpoints 2, 4, 6 and 8) in the FX2 are designed to move high speed (480 Mbits/sec) USB data on and off chip without introducing any bandwidth bottlenecks. They accomplish this goal by implementing the following features:

1. Direct interface with outside logic, with the FX2's CPU out of the data path.
2. "Quantum FIFO" architecture instantaneously moves ("commits") packets between the USB and the FIFOs.
3. Versatile interfaces: Slave FIFO (external master) or GPIF (internal master), synchronous or asynchronous clocking, internal or external clocks, etc.

The firmware sets switches to configure the outside FIFO interface, and then generally does not participate in moving the data into and out of the FIFOs.

To understand the "Quantum FIFO", it is necessary to refer to two data domains, the *USB domain* and the *Interface domain*. Each domain is independent, allowing different clocks and logic to handle its data.

The USB domain is serviced by the SIE, which receives and delivers FIFO data packets over the two-wire USB bus. The USB domain is clocked using a reference derived from the 24 MHz crystal attached to the FX2 chip.

The Interface domain loads and unloads the endpoint FIFOs. An external device such as a DSP or ASIC can supply its own clock to the FIFO interface, or the FX2's internal interface clock (IFCLK) can be supplied to the interface.

The classic solution to the problem of reconciling two different and independent clocks is to use a FIFO. The FX2's FIFOs have an unusual property: They're *Quantum* FIFOs, which means that data is committed to the FIFOs in USB-size packets, rather than one byte at a time. This is invisible to the outside interface, since it services the FIFOs just like any ordinary FIFO (i.e., by checking full and empty flags). The only minor difference is that when an empty flag goes from 1 (empty) to 0 (not empty), the number of bytes in the FIFO jumps to a USB packet size, rather than just one byte.

FX2 Quantum FIFOs may be moved between data domains almost instantaneously. The Quantum nature of the FIFOs also simplifies error recovery. If endpoint data were continuously clocked into an interface FIFO, some of the packet data might have already been clocked out by the time an error is detected at the end of a USB packet. By switching FIFO data between the domains in USB-packet-size blocks, each USB packet can be error-checked (and retried, if necessary) before it's committed to the other domain.

Figures 1-16 and 1-17 illustrate the two methods by which external logic interfaces to the endpoint FIFOs EP2, EP4, EP6 and EP8.

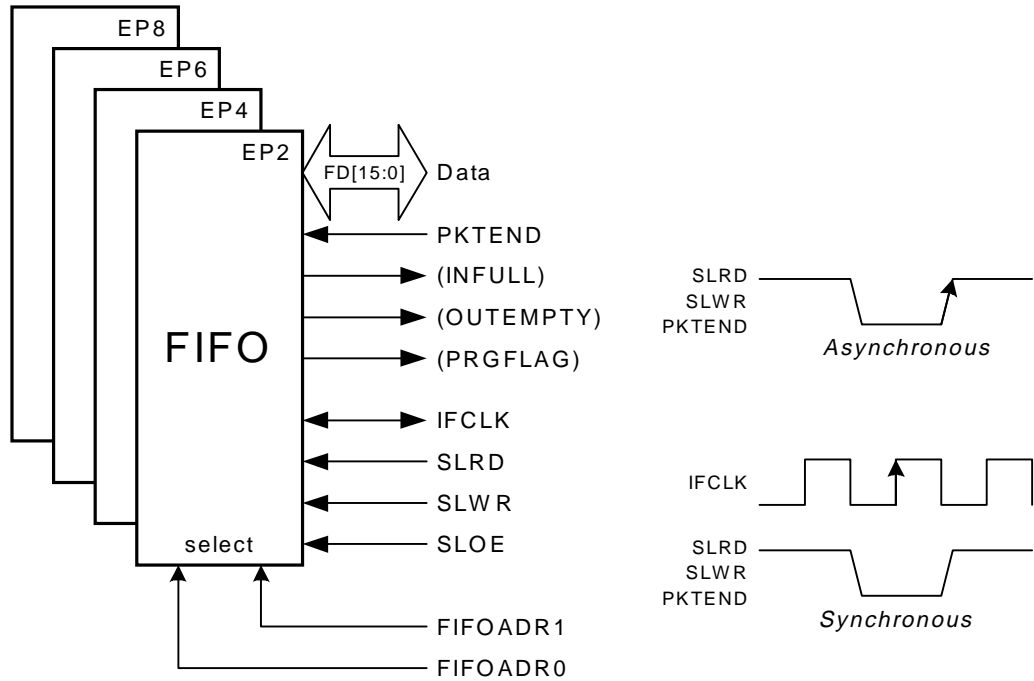

Figure 1-16. FX2 FIFOs in "Slave FIFO" Mode

Figure 1-16 illustrates the outside-world view of the FX2 data FIFOs configured as "Slave FIFOs". The outside logic supplies a clock, responds to the FIFO flags, and clocks FIFO data in and out using the strobe signals. Optionally, the outside logic may use the internal FX2 Interface Clock (IFCLK) as its reference clock.

Three FIFO flags are shown in parentheses in Figure 1-16 because they actually are called FLAGA-FLAGD in the pin diagram (there are four flag pins). Using configuration bits, various FIFO flags can be assigned to these general-purpose flag pins. The names shown in parentheses illustrate typical uses for these configurable flags. The Programmable Level Flag (PRGFLAG) can be set to any value to indicate degrees of FIFO "fullness". The outside interface selects one of the four FIFOs using the FIFOADR pins, and then clocks the 16-bit FIFO data using the SLRD (Slave Read) and SLWR (Slave Write) signals. PKTEND is used to dispatch a non-full IN packet to USB.



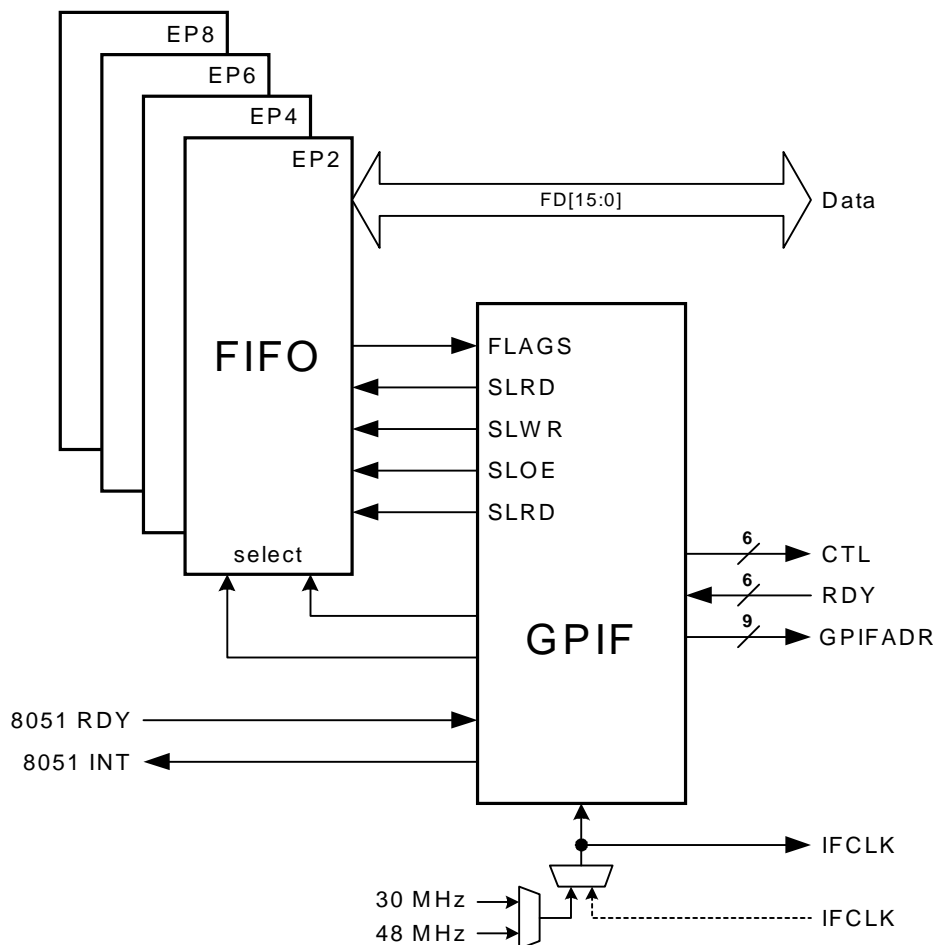

Figure 1-17. FX2 FIFOs in “GPIF Master” Mode

External systems that connect to the FX2 FIFOs must provide control circuitry to select FIFOs, check flags, clock data, etc. FX2 contains a sophisticated control unit (the General Programmable Interface, or GPIF) which can replace this external logic. In the “GPIF Master” FIFO mode, (Figure 1-17), the GPIF reads the FIFO flags, controls the FIFO strobes, and presents a user-customizable interface to the outside world. The GPIF runs at a very high speed (up to 48 MHz clock rate) so that it can develop high-resolution control waveforms. It can be clocked from one of two internal sources (30 or 48 MHz) or from an external clock.

Control (CTL) signals are programmable waveform outputs, and ready (RDY) signals are pins that can be tested for conditions that cause the GPIF to pause and resume operation, implementing

“wait states”. GPIFADR pins present a 9-bit address to the interface that may be incremented as data is transferred. The 8051 INT signal is a ‘hook’ that can signal the FX2’s CPU in the middle of a transaction; GPIF operation resumes once the CPU asserts its own 8051 RDY signal. This ‘hook’ permits great flexibility in the generation of GPIF waveforms.

---

## 1.20 EZ-USB FX2 Product Family

---

The EZ-USB FX2 family is available in various pinouts to serve different system requirements and costs.

Table 1-3. EZ-USB FX2 Family

Part Number	Package	Ram	ISO Support	I/O	Bus Width	Data/Address Bus
CY7C68013-56PVC	56-pin SSOP	8 KBytes	Yes	24	8/16 Bits	No
CY7C68013-100AC	100-pin TQFP	8 KBytes	Yes	40	8/16 Bits	No
CY7C68013-128AC	128-pin TQFP	8 KBytes	Yes	40	8/16 Bits	8051 Address/Data Bus

---

## Chapter 2 Endpoint Zero

---

### 2.1 Introduction

---

Endpoint zero has special significance in a USB system. It is a CONTROL endpoint, and it is required by every USB device. The USB host uses special SETUP tokens to signal transfers that deal with device control; only CONTROL endpoints accept these special tokens.

The USB host sends a suite of standard device requests over endpoint zero. These standard requests are fully defined in Chapter 9 of the *USB Specification*. This chapter describes how the FX2 chip handles endpoint zero requests.

The FX2 provides extensive hardware support for handling endpoint-zero operations; this chapter describes those operations and the FX2 resources that simplify the firmware which handles them.

Endpoint zero is the only CONTROL endpoint supported by the FX2. CONTROL endpoints are *bi-directional*, so the FX2 provides a single 64-byte buffer, EP0BUF, which firmware handles exactly like a bulk endpoint buffer for the data stages of a CONTROL transfer. A second 8-byte buffer called SETUPDAT, which is unique to endpoint zero, holds data that arrives in the SETUP stage of a CONTROL transfer. This relieves the FX2 firmware of the burden of tracking the three CONTROL transfer phases (SETUP, DATA, and STATUS). The FX2 also generates separate interrupt requests for the various transfer phases, further simplifying code.

Endpoint zero is always enabled and accessible by the USB host.

## 2.2 Control Endpoint EP0

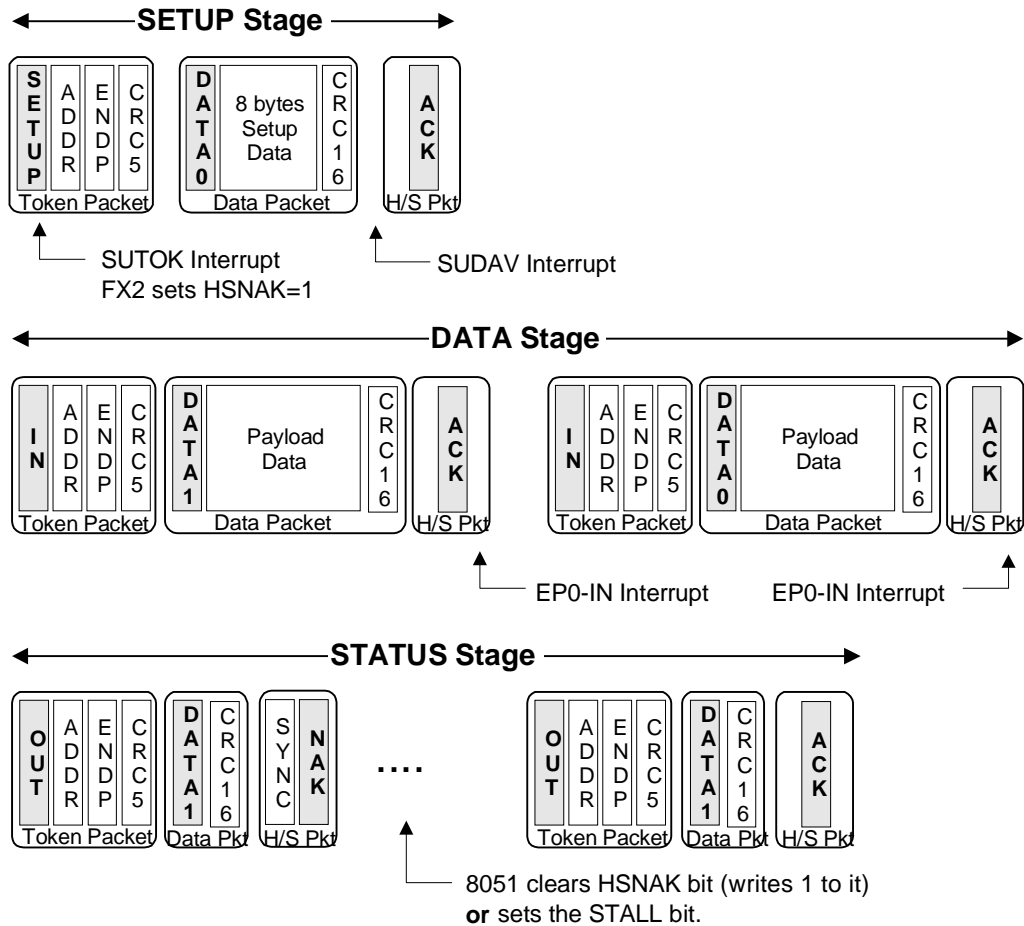

Figure 2-1. A USB Control Transfer (With Data Stage)

Endpoint zero accepts a special SETUP packet, which contains an 8-byte data structure that provides host information about the CONTROL transaction. CONTROL transfers include a final STATUS phase, constructed from standard PIDs (IN/OUT, DATA1, and ACK/NAK).

Some CONTROL transactions include all required data in their 8-byte SETUP Data packet. Other CONTROL transactions require more OUT data than will fit into the eight bytes, or require IN data from the device. These transactions use standard bulk-like transfers to move the data. Note in Figure 2-1 that the DATA Stage looks exactly like a bulk transfer. As with BULK endpoints, the endpoint zero byte count registers must be loaded to ACK each data transfer stage of a CONTROL transfer.

The STATUS stage consists of an empty data packet with the opposite direction of the data stage, or an IN if there was no data stage. This empty data packet gives the device a chance to ACK or NAK the entire CONTROL transfer.

The HSNACK bit holds off the completion of a CONTROL transfer until the device has had time to respond to a request. For example, if the host issues a Set\_Interface Request, the FX2 firmware performs various housekeeping chores such as adjusting internal modes and re-initializing endpoints. During this time, the host issues handshake (STATUS stage) packets to which the FX2 automatically responds with NAKs, indicating “busy.” When the firmware completes its housekeeping operations, it clears the HSNACK bit (*by writing 1 to it*), which instructs the FX2 to ACK the STATUS stage, terminating the transfer. This handshake prevents the host from attempting to use an interface before it’s fully configured.

To perform an endpoint stall for the DATA or STATUS stage of an endpoint zero transfer (the SETUP stage can never stall), firmware must set both the STALL and HSNACK bits for endpoint zero.

Some CONTROL transfers do not have a DATA stage. Therefore, the code that processes the SETUP data should check the length field in the SETUP data (in the 8-byte buffer at SETUPDAT) and arm endpoint zero for the DATA phase (by loading EPOBCH:L) only if the length field is non-zero.

Two interrupts provide notification that a SETUP packet has arrived, as shown in Figure2-2.

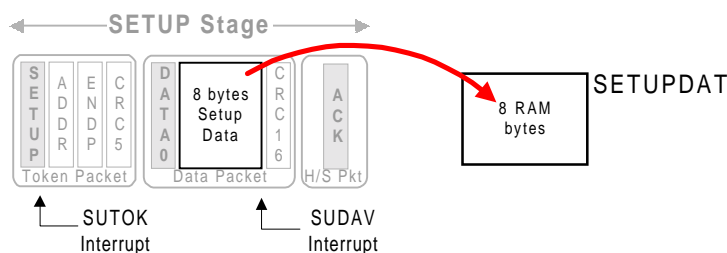

Figure 2-2. Two Interrupts Associated with EPO CONTROL Transfers

The FX2 asserts the SUTOK (Setup Token) interrupt request when it detects the SETUP token at the beginning of a CONTROL transfer. This interrupt is normally used for debug only.

The FX2 asserts the SUDAV (Setup Data Available) interrupt request when the eight bytes of SETUP data have been received error-free and transferred to the SETUPDAT buffer. The FX2 automatically takes care of any retries if it finds errors in the SETUP data. These two interrupt request bits must be cleared by firmware.

Firmware responds to the SUDAV interrupt request by either directly inspecting the eight bytes at SETUPDAT or by transferring them to a local buffer for further processing. Servicing the SETUP data should be a high priority, since the USB Specification stipulates that CONTROL transfers

must always be accepted and never NAK'd. It is possible, therefore, that a CONTROL transfer could arrive while the firmware is still servicing a previous one. In this case, the earlier CONTROL transfer service should be aborted and the new one serviced. The SUTOK interrupt gives advance warning that a new CONTROL transfer is about to overwrite the eight SETUPDAT bytes.

If the firmware stalls endpoint zero (by setting the STALL and HSNACK bits to 1), the FX2 automatically clears the stall bit when the next SETUP token arrives.

Like all FX2 interrupt requests, the SUTOK and SUDAV bits can be directly tested and cleared by the firmware (*cleared by writing 1*) even if their corresponding interrupts are disabled.

Figure 2-3 shows the FX2 registers that are associated with CONTROL transactions over EP0.

### Registers Associated with Endpoint Zero For handling SETUP transactions

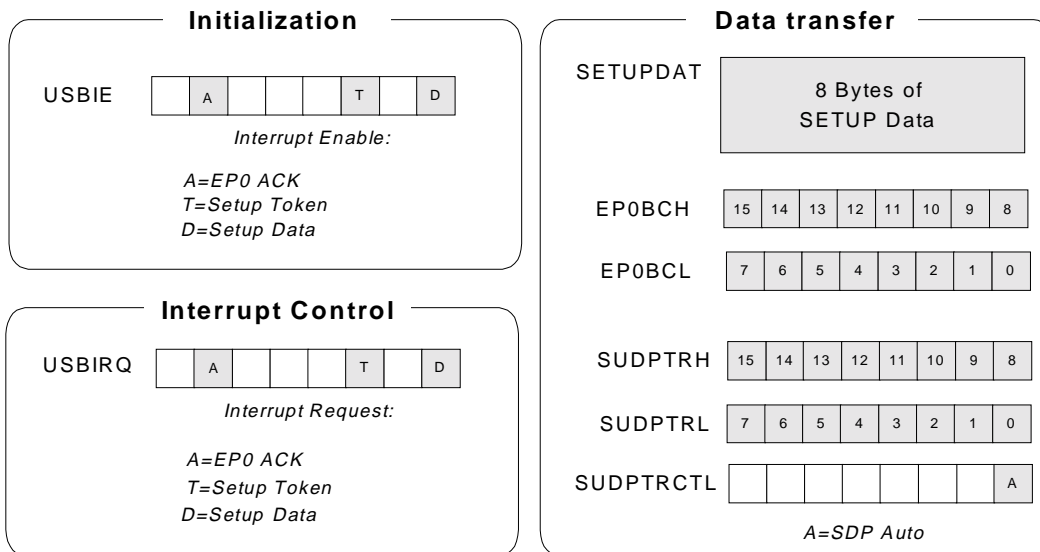

Figure 2-3. Registers Associated with EP0 Control Transfers

These registers augment those associated with normal bulk transfers over endpoint zero, which are described in *Chapter 8, "Access to Endpoint Buffers"*.

Two bits in the USBIE (USB Interrupt Enable) register enable the SETUP Token (SUTOK) and SETUP Data Available interrupts. The actual interrupt-request bits are in the USBIRQ (USB Interrupt Requests) register.

The FX2 transfers the eight SETUP bytes into eight bytes of RAM at SETUPDAT. A 16-bit pointer, SUDPTRH:L, provides hardware assistance for handling CONTROL IN transfers, in particular the *Get Descriptor* requests described later in this chapter.

## 2.3 USB Requests

The *Universal Serial Bus Specification Version 2.0, Chapter 9, "USB Device Framework"* defines a set of *Standard Device Requests*. When the firmware is in control of endpoint zero ( $RENUM=1$ ), the FX2 handles only one of these requests (*Set Address*) automatically; it relies on the firmware to support all of the others. The firmware acts on device requests by decoding the eight bytes contained in the SETUP packet and available at SETUPDAT. Table 2-1 defines these eight bytes.

Table 2-1. The Eight Bytes in a USB SETUP Packet

Byte	Field	Meaning
0	bmRequestType	Request Type, Direction, and Recipient.
1	bRequest	The actual request (see Table 2-2).
2	wValueL	16-bit value, varies according to bRequest.
3	wValueH	
4	wIndexL	16-bit field, varies according to bRequest.
5	wIndexH	
6	wLengthL	Number of bytes to transfer if there is a data phase.
7	wLengthH	

The **Byte** column in the previous table shows the byte offset from SETUPDAT. The **Field** column shows the different bytes in the request, where the "bm" prefix means bit-map, "b" means byte [8 bits, 0-255], and "w" means word [16 bits, 0-65535].

Table 2-2 shows the different values defined for bRequest, and how the firmware should respond to each request. The remainder of this chapter describes each of the requests in Table 2-2 in detail.



*Table 2-2 applies when  $RENUM=1$ , signifying that the firmware, rather than the FX2 hardware, handles device requests*

Table 2-2. How the Firmware Handles USB Device Requests (RENUM=1)

bRequest	Name	FX2 Action	Firmware Response
0x00	Get Status	SUDAV Interrupt	Supply RemWU, SelfPwr or Stall Bits
0x01	Clear Feature	SUDAV Interrupt	Clear RemWU, SelfPwr or Stall Bits
0x02	(reserved)	none	Stall EP0
0x03	Set Feature	SUDAV Interrupt	Set RemWU, SelfPwr or Stall Bits
0x04	(reserved)	none	Stall EP0
0x05	Set Address	Update FNADDR Register	none
0x06	Get Descriptor	SUDAV Interrupt	Supply table data over EP0-IN
0x07	Set Descriptor	SUDAV Interrupt	Application dependent
0x08	Get Configuration	SUDAV Interrupt	Send current configuration number
0x09	Set Configuration	SUDAV Interrupt	Change current configuration
0x0A	Get Interface	SUDAV Interrupt	Supply alternate setting No. from RAM
0x0B	Set Interface	SUDAV Interrupt	Change alternate setting No.
0x0C	Sync Frame	SUDAV Interrupt	Supply a frame number over EP0-IN
<b>Vendor Requests</b>			
0xA0 (Firmware Load)		Upload / Download RAM	---
0xA1 - 0xAF		SUDAV Interrupt	Reserved by Cypress Semiconductor
All except 0xA0		SUDAV Interrupt	Depends on application

In the ReNumerated condition (RENUM=1), the FX2 passes all USB requests except *Set Address* to the firmware via the SUDAV interrupt.

The FX2 implements one vendor-specific request: “Firmware Load,” 0xA0 (the bRequest value of 0xA0 is valid only if byte 0 of the request, bmRequestType, is also “x10xxxx,” indicating a vendor-specific request.) The load request is valid at all times, so the load feature may be used even after ReNumeration. If your application implements vendor-specific USB requests, and you do *not* wish to use the Firmware Load feature, be sure to refrain from using the bRequest value 0xA0 for your custom requests. The Firmware Load feature is fully described in *Chapter 3, “Enumeration and ReNumeration™”*.

To avoid future incompatibilities, vendor requests 0xA0-0xAF are reserved by Cypress Semiconductor.



### 2.3.1 Get Status

The USB Specification defines three USB status requests. A fourth request, to an interface, is declared in the spec as “reserved.” The four status requests are:

- Remote Wakeup (Device request)
- Self-Powered (Device request)
- Stall (Endpoint request)
- Interface request (reserved)

The FX2 automatically asserts the SUDAV interrupt to tell the firmware to decode the SETUP packet and supply the appropriate status information.

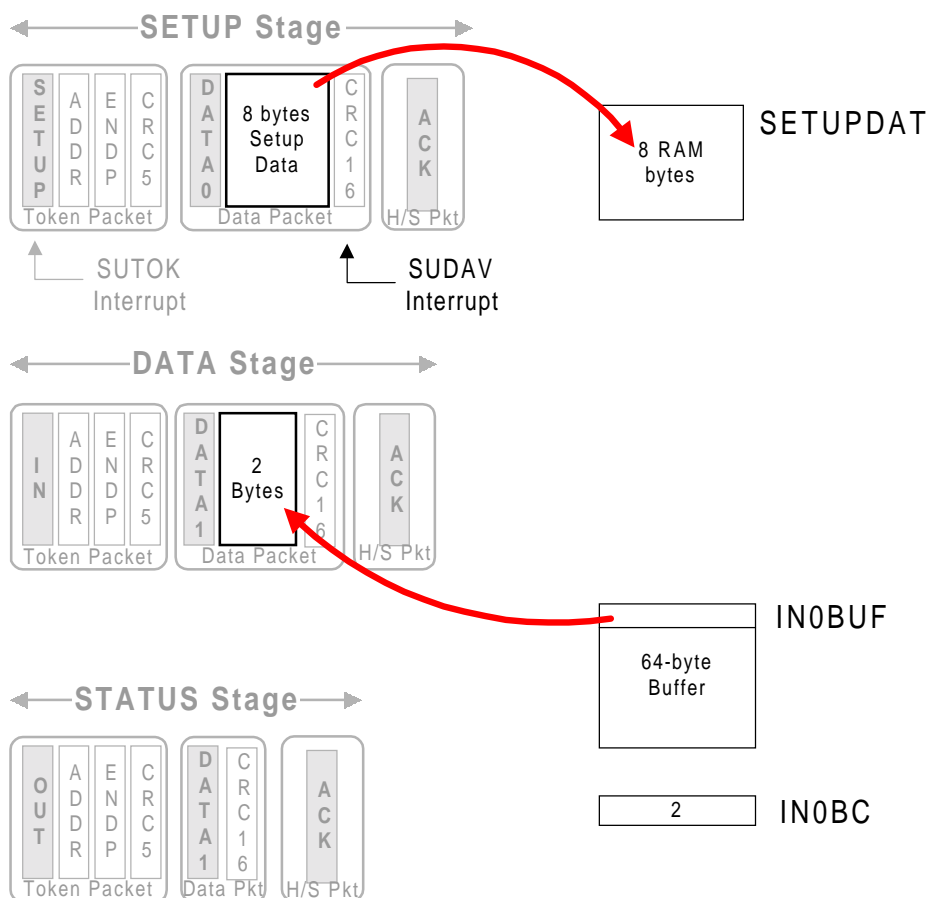

Figure 2-4. Data Flow for a Get\_Status Request

As Figure 2-4 illustrates, the firmware responds to the SUDAV interrupt by decoding the eight bytes the FX2 has copied into RAM at SETUPDAT. The firmware answers a *Get Status* request (bRequest=0) by loading two bytes into the EP0BUF buffer and loading the byte count register EP0BCH:L with the value 0x0002. The FX2 then transmits these two bytes in response to an IN token. Finally, the firmware clears the HSNACK bit (*by writing 1 to it*), which instructs the FX2 to ACK the status stage of the transfer.

The following tables show the eight SETUP bytes for *Get Status* Requests.

Table 2-3. *Get Status-Device (Remote Wakeup and Self-Powered Bits)*

Byte	Field	Value	Meaning	Firmware Response
0	bmRequestType	0x80	IN, Device	Load two bytes into EP0BUF:  Byte 0 : bit 0 = Self-Powered : bit 1 = Remote Wakeup  Byte 1 : zero
1	bRequest	0x00	"Get Status"	
2	wValueL	0x00		
3	wValueH	0x00		
4	wIndexL	0x00		
5	wIndexH	0x00		
6	wLengthL	0x02	Two bytes requested	
7	wLengthH	0x00		

*Get Status-Device* queries the state of two bits, "Remote Wakeup" and "Self-Powered". The Remote Wakeup bit indicates whether or not the device is currently enabled to request remote wakeup (remote wakeup is explained in *Chapter 6, "Power Management"*). The Self-Powered bit indicates whether or not the device is self-powered (as opposed to USB bus-powered).

The firmware returns these two bits by loading two bytes into EP0BUF, then loading a byte count of 0x0002 into EP0BCH:L.

Table 2-4. *Get Status-Endpoint (Stall Bits)*

Byte	Field	Value	Meaning	Firmware Response
0	bmRequestType	0x82	IN, Endpoint	Load two bytes into EP0BUF:  Byte 0 : bit 0 = Stall Bit for EP(n)  Byte 1 : zero
1	bRequest	0x00	"Get Status"	
2	wValueL	0x00		
3	wValueH	0x00		
4	wIndexL	EP	0x00-0x08: OUT0-OUT8	
5	wIndexH	0x00	0x80-0x88: IN0-IN8	
6	wLengthL	0x02	Two bytes requested	
7	wLengthH	0x00		

Each endpoint has a STALL bit in its EPxCS register. If this bit is set, any request to the endpoint returns a STALL handshake rather than ACK or NAK. The *Get Status-Endpoint* request returns the STALL state for the endpoint indicated in byte 4 of the request. Note that bit 7 of the endpoint number EP (byte 4) specifies direction (0 = OUT, 1 = IN).

Endpoint zero is a CONTROL endpoint, which by USB definition is *bi-directional*. Therefore, it has only one stall bit.

### **About STALL**

The USB STALL handshake indicates that something unexpected has happened. For instance, if the host requests an invalid alternate setting or attempts to send data to a non-existent endpoint, the device responds with a STALL handshake over endpoint zero instead of ACK or NAK.

Stalls are defined for all endpoint types except ISOCRONOUS, which does not employ handshakes. Every FX2 bulk endpoint has its own stall bit. The firmware sets the stall condition for an endpoint by setting the STALL bit in the endpoint's EPxCS register. The host tells the firmware to set or clear the stall condition for an endpoint using the *Set Feature/Stall* and *Clear Feature/Stall* Requests.

The device might decide to set the stall condition on its own, too. In a routine that handles endpoint zero device requests, for example, when an undefined or non-supported request is decoded, the firmware should stall EP0.

Once the firmware stalls an endpoint, it should not remove the stall until the host issues a *Clear Feature/Stall* Request. An exception to this rule is endpoint 0, which reports a stall condition only for the current transaction and then automatically clears the stall condition. This prevents endpoint 0, the default CONTROL endpoint, from locking out device requests.

*Table 2-5. Get Status-Interface*

Byte	Field	Value	Meaning	Firmware Response
0	bmRequestType	<b>0x81</b>	IN, Endpoint	<i>Load two bytes into EP0BUF: Byte 0 : zero Byte 1 : zero</i>
1	bRequest	<b>0x00</b>	"Get Status"	
2	wValueL	0x00		
3	wValueH	0x00		
4	wIndexL	0x00		
5	wIndexH	0x00		
6	wLengthL	<b>0x02</b>	Two bytes requested	
7	wLengthH	<b>0x00</b>		

*Get Status/Interface* is easy: the firmware returns two zero bytes through EP0BUF and clears the HSNACK bit (*by writing 1 to it*). The requested bytes are shown as "Reserved (reset to zero)" in the USB Specification.

## 2.3.2 Set Feature

*Set Feature* is used to enable remote wakeup or stall an endpoint. No data stage is required.

Table 2-6. *Set Feature-Device (Set Remote Wakeup Bit)*

Byte	Field	Value	Meaning	Firmware Response
0	bmRequestType	0x00	OUT, Device	<i>Set the Remote Wakeup Bit</i>
1	bRequest	0x03	"Set Feature"	
2	wValueL	0x01	Feature Selector:	
3	wValueH	0x00	Remote Wakeup	
4	wIndexL	0x00		
5	wIndexH	0x00		
6	wLengthL	0x00		
7	wLengthH	0x00		

The only *Set Feature/Device* request presently defined in the USB Specification is to set the remote wakeup bit. This is the same bit reported back to the host as a result of a *Get Status-Device* request (Table 2-3). The host uses this bit to enable or disable remote wakeup by the device.

Table 2-7. *Set Feature-Endpoint (Stall)*

Byte	Field	Value	Meaning	Firmware Response
0	bmRequestType	0x02	OUT, Endpoint	<i>Set the STALL bit for the indicated endpoint:.</i>
1	bRequest	0x03	"Set Feature"	
2	wValueL	0x00	Feature Selector:	
3	wValueH	0x00	STALL	
4	wIndexL	EP	0x00-0x08: OUT0-OUT8	
5	wIndexH	0x00	0x80-0x88: IN0-IN8	
6	wLengthL	0x00		
7	wLengthH	0x00		

The only *Set Feature/Endpoint* request presently defined in the USB Specification is to stall an endpoint. The firmware should respond to this request by setting the STALL bit in the EPxCS register for the indicated endpoint EP (byte 4 of the request). The firmware can either stall an endpoint on its own or in response to the device request. Endpoint stalls are cleared by the host *Clear Feature/Stall* request.

The firmware should respond to the *Set Feature/Stall* request by performing the following tasks:

1. Set the STALL bit in the indicated endpoint's EPxCS register.
2. Reset the data toggle for the indicated endpoint.

3. Restore the stalled endpoint to its default condition, ready to send or accept data after the stall condition is removed by the host (via a *Clear Feature/Stall* request). For EP1 IN, for example, firmware should clear the BUSY bit in the EP1CS register; for EP1OUT, firmware should load any value into the EP1 byte-count register.
4. Clear the HSNACK bit in the EP0CS register (*by writing 1 to it*) to terminate the *Set Feature/Stall CONTROL* transfer.

Step 3 is also required whenever the host sends a *Set Interface* request.

### **Data Toggles**

The FX2 automatically maintains the endpoint toggle bits to ensure data integrity for USB transfers. Firmware should directly manipulate these bits only for a very limited set of circumstances:

- *Set Feature/Stall*
- *Set Configuration*
- *Set Interface*

---

### **2.3.3 Clear Feature**

*Clear Feature* is used to disable remote wakeup or to clear a stalled endpoint.

*Table 2-8. Clear Feature-Device (Clear Remote Wakeup Bit)*

Byte	Field	Value	Meaning	Firmware Response
0	bmRequestType	<b>0x00</b>	OUT, Device	<i>Clear the remote wakeup bit.</i>
1	bRequest	<b>0x01</b>	“Clear Feature”	
2	wValueL	<b>0x01</b>	Feature Selector: Remote Wakeup	
3	wValueH	0x00		
4	wIndexL	0x00		
5	wIndexH	0x00		
6	wLengthL	0x00		
7	wLengthH	0x00		

Table 2-9. Clear Feature-Endpoint (Clear Stall)

Byte	Field	Value	Meaning	Firmware Response
0	bmRequestType	0x02	OUT, Endpoint	Clear the STALL bit for the indicated endpoint.
1	bRequest	0x01	“Clear Feature”	
2	wValueL	0x00	Feature Selector:	
3	wValueH	0x00	STALL	
4	wIndexL	EP	0x00-0x08: OUT0-OUT8	
5	wIndexH	0x00	0x80-0x88: IN0-IN8	
6	wLengthL	0x00		
7	wLengthH	0x00		

If the USB device supports remote wakeup (reported in its descriptor table when the device enumerates), the *Clear Feature/Remote Wakeup* request disables the wakeup capability.

The *Clear Feature/Stall* removes the stall condition from an endpoint. The firmware should respond by clearing the STALL bit in the indicated endpoint's EPxCS register.

---

### 2.3.4 Get Descriptor

During enumeration, the host queries a USB device to learn its capabilities and requirements using *Get Descriptor* requests. Using tables of *descriptors*, the device sends back (over EP0-IN) such information as what device driver to load, how many endpoints it has, its different configurations, alternate settings it may use, and informative text strings about the device.

The FX2 provides a special *Setup Data Pointer* to simplify firmware service for *Get\_Descriptor* requests. The firmware loads this 16-bit pointer with the starting address of the requested descriptor, clears the HSNACK bit (*by writing 1 to it*), and the FX2 transfers the entire descriptor.

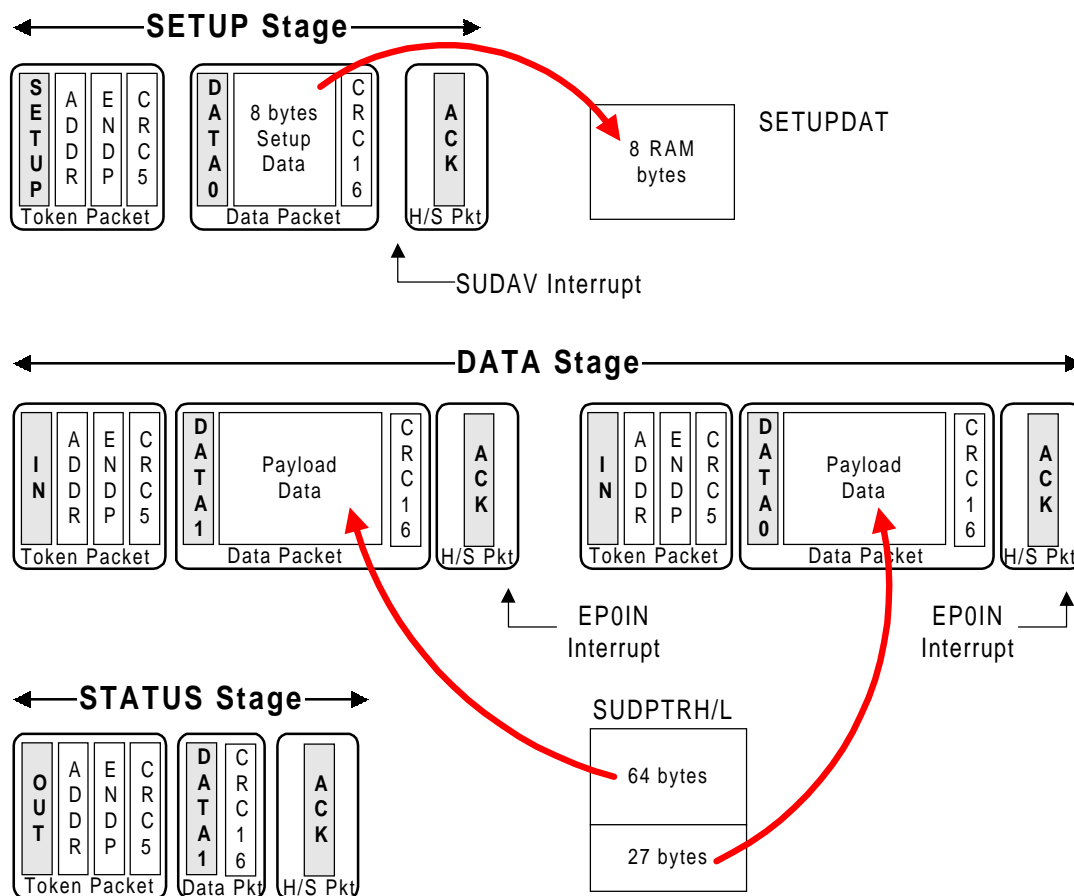

Figure 2-5. Using Setup Data Pointer (SUDPTR) for Get\_Descriptor Requests

Figure 2-5 illustrates use of the Setup Data Pointer. This pointer is implemented as two registers, SUDPTRH and SUDPTRL. Most *Get Descriptor* requests involve transferring more data than fits into one packet. In the Figure2-5 example, the descriptor data consists of 91 bytes.

The CONTROL transaction starts in the usual way, with theFX2 automatically transferring the eight bytes from the SETUP packet into RAM at SETUPDAT, then asserting the SUDAV interrupt request. The firmware decodes the *Get Descriptor* request, and responds by clearing the HSNACK bit (*by writing 1 to it*), and then loading the SUDPTRH:L registers with the address of the requested descriptor. Loading the SUDPTRL register causes the FX2 to automatically respond to two IN transfers with 64 bytes and 27 bytes of data using SUDPTR as a base address, and then to respond to the STATUS stage with an ACK.

The usual endpoint-zero interrupts SUDAV and EP0IN remain active during this automated transfer, so firmware will normally disables these interrupts because the transfer requires no firmware intervention.

Three types of descriptors are defined: Device, Configuration, and String.

### 2.3.4.1 Get Descriptor-Device

Table 2-10. Get Descriptor-Device

Byte	Field	Value	Meaning	Firmware Response
0	bmRequestType	<b>0x80</b>	IN, Device	Set SUDPTR H:L to start of Device Descriptor table in RAM.
1	bRequest	<b>0x06</b>	"Get Descriptor"	
2	wValueL	0x00		
3	wValueH	<b>0x01</b>	Descriptor Type: Device	
4	wIndexL	0x00		
5	wIndexH	0x00		
6	wLengthL	<b>LenL</b>		
7	wLengthH	<b>LenH</b>		

As illustrated in Figure 2-5, the firmware loads the 2-byte SUDPTR with the starting address of the Device Descriptor table. When SUDPTRL is loaded, the FX2 automatically performs the following operations:

1. Reads the requested number of bytes for the transfer from bytes 6 and 7 of the SETUP packet (**LenL** and **LenH** in Table 2-10).
2. Reads the requested descriptor's length field to determine the actual descriptor length.
3. Sends the smaller of (a) the requested number of bytes or (b) the actual number of bytes in the descriptor, over EP0BUF using the Setup Data Pointer as a data table index. This constitutes the second phase of the three-phase CONTROL transfer. The FX2 packetizes the data into multiple data transfers as necessary.
4. Automatically checks for errors and re-transmits data packets if necessary.
5. Responds to the third (handshake) phase of the CONTROL transfer to terminate the operation.

The Setup Data Pointer can be used for any *Get Descriptor* request (e.g., *Get Descriptor-String*).

It can also be used for vendor-specific requests. If bytes 6 and 7 of those requests contain the number of bytes in the transfer (see Step 1, above), the Setup Data Pointer works automatically, as it does for Get Descriptor requests; if bytes 6 and 7 don't contain the length of the transfer, the length can be loaded explicitly (see the SDPAUTO paragraphs of Section 8.7, "The Setup Data Pointer").

It is possible for the firmware to do *manual* CONTROL transfers by directly loading the EP0BUF buffer with the various packets and keeping track of which SETUP phase is in effect. This is a good USB training exercise, but not necessary due to the hardware support built into the FX2 for CONTROL transfers.

For DATA stage transfers of fewer than 64 bytes, moving the data into the EP0BUF buffer and then loading the EP0BCH:L registers with the byte count would be equivalent to loading the Setup



Data Pointer. However, this would waste bandwidth because it requires byte transfers into the EP0BUF Buffer; using the Setup Data Pointer doesn't.

### 2.3.4.2 Get Descriptor-Device Qualifier

Table 2-11. Get Descriptor-Device Qualifier

Byte	Field	Value	Meaning	Firmware Response
0	bmRequestType	<b>0x80</b>	IN, Device	<i>Set SUDPTR H:L to start of the appropriate Device Qualifier Descriptor table in RAM.</i>
1	bRequest	<b>0x06</b>	"Get_Descriptor"	
2	wValueL	0x00		
3	wValueH	<b>0x06</b>	Descriptor Type: Device Qualifier	
4	wIndexL	0x00		
5	wIndexH	0x00		
6	wLengthL	<b>LenL</b>		
7	wLengthH	<b>LenH</b>		

The Device Qualifier descriptor is used only by devices capable of high-speed (480 Mbps) operation; it describes information about the device that would change if the device were operating at the other speed (i.e., if the device is currently operating at high speed, the device qualifier returns information about how it would operate at full speed and vice-versa).

Device Qualifier descriptors are handled just like Device descriptors; the firmware loads the appropriate descriptor address into SUDPTRH:L, then the FX2 does the rest.

### 2.3.4.3 Get Descriptor-Configuration

Table 2-12. Get Descriptor-Configuration

Byte	Field	Value	Meaning	Firmware Response
0	bmRequestType	<b>0x80</b>	IN, Device	<i>Set SUDPTR H:L to start of Configuration Descriptor table in RAM</i>
1	bRequest	<b>0x06</b>	"Get_Descriptor"	
2	wValueL	<b>CFG</b>	Configuration Number	
3	wValueH	<b>0x02</b>	Descriptor Type: Configuration	
4	wIndexL	0x00		
5	wIndexH	0x00		
6	wLengthL	<b>LenL</b>		
7	wLengthH	<b>LenH</b>		

### 2.3.4.4 Get Descriptor-String

Table 2-13. Get Descriptor-String

Byte	Field	Value	Meaning	Firmware Response
0	bmRequestType	<b>0x80</b>	IN, Device	<i>Set SUDPTR H:L to start of String Descriptor table in RAM.</i>
1	bRequest	<b>0x06</b>	"Get_Descriptor"	
2	wValueL	<b>STR</b>	String Number	
3	wValueH	<b>0x03</b>	Descriptor Type: String	
4	wIndexL	0x00	(Language ID L)	
5	wIndexH	0x00	(Language ID H)	
6	wLengthL	<b>LenL</b>		
7	wLengthH	<b>LenH</b>		

Configuration and String descriptors are handled similarly to Device descriptors. The firmware reads byte 2 of the SETUP data to determine which configuration or string is being requested, then loads the corresponding descriptor address into SUDPTRH:L. The FX2 does the rest.

### 2.3.4.5 Get Descriptor-Other Speed Configuration

Table 2-14. Get Descriptor-Other Speed Configuration

Byte	Field	Value	Meaning	Firmware Response
0	bmRequestType	<b>0x80</b>	IN, Device	<i>Set SUDPTR H:L to start of Other Speed Configuration Descriptor table in RAM.</i>
1	bRequest	<b>0x06</b>	"Get_Descriptor"	
2	wValueL	<b>CFG</b>	Other Speed Configuration Number	
3	wValueH	<b>0x07</b>	Descriptor Type: Other Speed Configuration	
4	wIndexL	0x00	(Language ID L)	
5	wIndexH	0x00	(Language ID H)	
6	wLengthL	<b>LenL</b>		
7	wLengthH	<b>LenH</b>		

The Other Speed Configuration descriptor is used only by devices capable of high-speed (480 Mbps) operation; it describes the configuration(s) of the device if it were operating at the other speed (i.e., if the device is currently operating at high speed, the Other Speed Configuration returns information about full-speed configuration and vice-versa).

Other Speed Configuration descriptors are handled just like Configuration descriptors; the firmware loads the appropriate descriptor address into SUDPTRH:L, then the FX2 does the rest.

## 2.3.5 Set Descriptor

Table 2-15. Set Descriptor-Device

Byte	Field	Value	Meaning	Firmware Response
0	bmRequestType	<b>0x00</b>	OUT, Device	<i>Read device descriptor data over EP0BUF.</i>
1	bRequest	<b>0x07</b>	"Set_Descriptor"	
2	wValueL	0x00		
3	wValueH	<b>0x01</b>	Descriptor Type: Device	
4	wIndexL	0x00		
5	wIndexH	0x00		
6	wLengthL	<b>LenL</b>		
7	wLengthH	<b>LenH</b>		

Table 2-16. Set Descriptor-Configuration

Byte	Field	Value	Meaning	Firmware Response
0	bmRequestType	<b>0x00</b>	OUT, Device	<i>Read configuration descriptor data over EP0BUF.</i>
1	bRequest	<b>0x07</b>	"Set_Descriptor"	
2	wValueL	0x00		
3	wValueH	<b>0x02</b>	Descriptor Type: Configuration	
4	wIndexL	0x00		
5	wIndexH	0x00		
6	wLengthL	<b>LenL</b>		
7	wLengthH	<b>LenH</b>		

Table 2-17. Set Descriptor-String

Byte	Field	Value	Meaning	Firmware Response
0	bmRequestType	<b>0x00</b>	IN, Device	<i>Read string descriptor data over EP0BUF.</i>
1	bRequest	<b>0x07</b>	“Get_Descriptor”	
2	wValueL	0x00	String Number	
3	wValueH	0x03	Descriptor Type: String	
4	wIndexL	0x00	(Language ID L)	
5	wIndexH	0x00	(Language ID H)	
6	wLengthL	<b>LenL</b>		
7	wLengthH	<b>LenH</b>		

The firmware handles *Set Descriptor* requests by clearing the HSNAK bit (*by writing 1 to it*), then reading descriptor data directly from the EP0BUF buffer. The FX2 keeps track of the number of bytes transferred from the host into EP0BUF, and compares this number with the length field in bytes 6 and 7. When the proper number of bytes has been transferred, the FX2 automatically responds to the STATUS phase, which is the third and final stage of the CONTROL transfer.



*The firmware controls the flow of data in the Data Stage of a Control Transfer. After the firmware processes each OUT packet, it writes any value into the endpoint's byte count register to re-arm the endpoint.*

## Configurations, Interfaces, and Alternate Settings

A USB device has one or more **configurations**. Only one configuration is active at any time.

A configuration has one or more **interfaces**, all of which are concurrently active. Multiple interfaces allow different host-side device drivers to be associated with different portions of a USB device.

Each interface has one or more **alternate settings**. Each alternate setting has a collection of one or more endpoints.

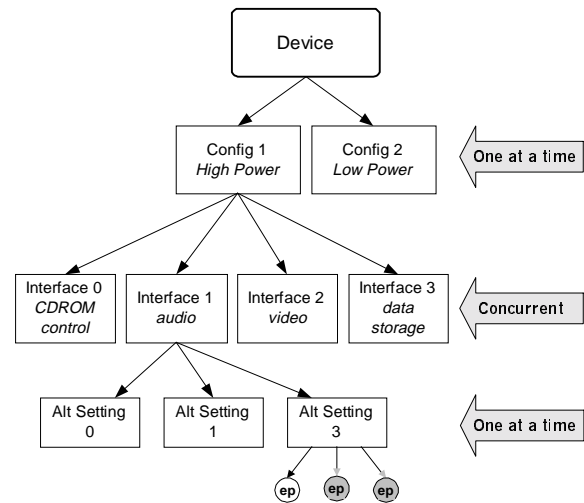

This structure is a software model; the FX2 takes no action when these settings change. However, the firmware **must re-initialize endpoints** when the host changes configurations or interfaces alternate settings.

As far as the firmware is concerned, a *configuration* is simply a byte variable that indicates the current setting.

The host issues a *Set Configuration* request to select a configuration, and a *Get Configuration* request to determine the current configuration.

### 2.3.5.1 Set Configuration

Table 2-18. Set Configuration

Byte	Field	Value	Meaning	Firmware Response
0	bmRequestType	0x00	OUT, Device	<i>Read and store CFG, change configurations in firmware.</i>
1	bRequest	0x09	“Set Configuration”	
2	wValueL	CFG	Configuration Number	
3	wValueH	0x00		
4	wIndexL	0x00		
5	wIndexH	0x00		
6	wLengthL	0x00		
7	wLengthH	0x00		

When the host issues the *Set Configuration* request, the firmware saves the configuration number (byte 2, CFG, in Table 2-18), performs any internal operations necessary to support the configuration, and finally clears the HSNACK bit (*by writing 1 to it*) to terminate the *Set Configuration* CONTROL transfer.



*After setting a configuration, the host issues Set Interface commands to set up the various interfaces contained in the configuration.*

---

### 2.3.6 Get Configuration

Table 2-19. Get Configuration

Byte	Field	Value	Meaning	Firmware Response
0	bmRequestType	0x80	IN, Device	<i>Send CFG over EP0 after re-configuring.</i>
1	bRequest	0x08	“Get Configuration”	
2	wValueL	0x00		
3	wValueH	0x00		
4	wIndexL	0x00		
5	wIndexH	0x00		
6	wLengthL	1	LenL	
7	wLengthH	0	LenH	

When the host issues the *Get Configuration* request, the firmware returns the current configuration number. It loads the configuration number into EP0BUF, loads a byte count of one into EP0BCH:L, and finally clears the HSHAK bit (*by writing 1 to it*) to terminate the *Set Configuration* CONTROL transfer.

## 2.3.7 Set Interface

This confusingly-named USB command actually sets *alternate settings* for a specified interface.

USB devices can have multiple concurrent interfaces. For example, a device may have an audio system that supports different sample rates, and a graphic control panel that supports different languages. Each interface has a collection of endpoints. Except for endpoint 0, which each interface uses for device control, endpoints may not be shared between interfaces.

Interfaces may report alternate settings in their descriptors. For example, the audio interface may have setting 0, 1, and 2 for 8-KHz, 22-KHz, and 44-KHz sample rates. The panel interface may have settings 0 and 1 for English and Spanish. The *Set/Get Interface* requests select among the various alternate settings in an interface.

Table 2-20. Set Interface (Actually, Set Alternate Setting #AS for Interface #IF)

Byte	Field	Value	Meaning	Firmware Response
0	bmRequestType	0x00	OUT, Device	<i>Read and store byte 2 (AS) for Interface #IF, change setting for Interface #IF in firmware.</i>
1	bRequest	0x0B	"Set Interface"	
2	wValueL	AS	Alternate Setting Number	
3	wValueH	0x00		
4	wIndexL	IF	Interface Number	
5	wIndexH	0x00		
6	wLengthL	0x00		
7	wLengthH	0x00		

The firmware should respond to a *Set Interface* request by performing the following steps:

1. Perform the internal operation requested (such as adjusting a sampling rate).
2. Reset the data toggles for every endpoint in the interface.
3. Restore the endpoints to their default conditions, ready to send or accept data. For EP1 IN, for example, firmware should clear the BUSY bit in the EP1CS register; for EP1OUT, firmware should load any value into the EP1 byte-count register.
4. Clear the HSNACK bit (*by writing 1 to it*) to terminate the *Set Interface* CONTROL transfer.

### 2.3.8 Get Interface

Table 2-21. Get Interface (Actually, Get Alternate Setting #AS for interface #IF)

Byte	Field	Value	Meaning	Firmware Response
0	bmRequestType	<b>0x81</b>	IN, Device	Send AS for Interface #IF over EPO.
1	bRequest	<b>0x0A</b>	"Get Interface"	
2	wValueL	0x00		
3	wValueH	0x00		
4	wIndexL	<b>IF</b>	Interface Number	
5	wIndexH	0x00		
6	wLengthL	<b>1</b>	LenL	
7	wLengthH	<b>0</b>	LenH	

When the host issues the *Get Interface* request, the firmware simply returns the alternate setting for the requested interface IF and clears the HSNACK bit (*by writing 1 to it*).

### 2.3.9 Set Address

When a USB device is first plugged in, it responds to device address 0 until the host assigns it a unique address using the *Set Address* request. The FX2 copies this device address into the FNADDR (Function Address) register, then subsequently responds only to requests to this address. This address is in effect until the USB device is unplugged, the host issues a USB Reset, or the host powers down.

The FNADDR register is read-only. Whenever the FX2 ReNumerates™ (see *Chapter 3, "Enumeration and ReNumeration™"*), it automatically resets FNADDR to zero, allowing the device to come back as *new*.

An FX2 program does not need to know the device address, because the FX2 automatically responds only to the host-assigned FNADDR value. The device address is readable only for debug/diagnostic purposes.



## 2.3.10 Sync Frame

Table 2-22. Sync Frame

Byte	Field	Value	Meaning	Firmware Response
0	bmRequestType	<b>0x82</b>	IN, Endpoint	<i>Send a frame number over EP0 to synchronize endpoint #EP</i>
1	bRequest	<b>0x0C</b>	“Sync Frame”	
2	wValueL	0x00		
3	wValueH	0x00		
4	wIndexL	<b>EP</b>	Endpoint number	
5	wIndexH	0x00		
6	wLengthL	<b>2</b>	LenL	
7	wLengthH	<b>0</b>	LenH	

The *Sync Frame* request is used to establish a marker in time so the host and USB device can synchronize multi-frame transfers over isochronous endpoints.

Suppose an isochronous transmission consists of a repeating sequence of five 300-byte packets transmitted from host to device over EP8-OUT. Both host and device maintain sequence counters that count repeatedly from 1 to 5 to keep track of the packets inside a transmission. To start up in sync, both host and device need to reset their counts to “0” at the same time (in the same frame).

To get in sync, the host issues the *Sync Frame* request with EP=EP8OUT (0x08). The firmware responds by loading EPOBUF with a two-byte frame count for some future time; for example, the current frame plus 20. This marks frame “current+20” as the sync frame, during which both sides initialize their sequence counters to “0.” The current frame count is always available in the USBFRAMEL and USBFRAMEH registers.

Multiple isochronous endpoints can be synchronized in this manner; the firmware can keep a separate internal sequence count for each endpoint.

### **About USB Frames**

In full-speed mode (12 Mbps), the USB host issues an SOF (Start Of Frame) packet once every millisecond. Every SOF packet contains an 11-bit (mod-2048) frame number. The firmware services all isochronous transfers at SOF time, using a single SOF interrupt request and vector. If the FX2 detects a missing or garbled SOF packet, it can use an internal counter to generate the SOF interrupt automatically.

In high-speed (480 Mbps) mode, each frame is divided into eight 125-microsecond microframes. Although the frame counter still increments only once per frame, the host issues an SOF every microframe. The host and device always synchronize on the zero-th microframe of the frame specified in the device’s response to the *Sync Frame* request; there’s no mechanism for synchronizing on any other microframe.

### 2.3.11 Firmware Load

The USB endpoint-zero protocol provides a mechanism for mixing vendor-specific requests with standard device requests. Bits 6:5 of the bmRequestType field are set to 00 for a standard device request and to 10 for a vendor request.

Table 2-23. Firmware Download

Byte	Field	Value	Meaning	Firmware Response
0	bmRequestType	<b>0x40</b>	Vendor Request, OUT	<i>None required.</i>
1	bRequest	<b>0xA0</b>	"Firmware Load"	
2	wValueL	<b>AddrL</b>	Starting address	
3	wValueH	<b>AddrH</b>		
4	wIndexL	0x00		
5	wIndexH	0x00		
6	wLengthL	<b>LenL</b>	Number of bytes	
7	wLengthH	<b>LenH</b>		

Table 2-24. Firmware Upload

Byte	Field	Value	Meaning	Firmware Response
0	bmRequestType	<b>0xC0</b>	Vendor Request, IN	<i>None Required.</i>
1	bRequest	<b>0xA0</b>	"Firmware Load"	
2	wValueL	<b>AddrL</b>	Starting address	
3	wValueH	<b>AddrH</b>		
4	wIndexL	0x00		
5	wIndexH	0x00		
6	wLengthL	<b>LenL</b>	Number of Bytes	
7	wLengthH	<b>LenH</b>		

The FX2 responds to two endpoint-zero vendor requests, RAM Download and RAM Upload. These requests are active whether RENUM=0 or RENUM=1.

Because bit 7 of the first byte of the SETUP packet specifies direction, only one bRequest value (0xA0) is required for the upload and download requests. These RAM load commands are available to any USB device that uses the FX2 chip.

A host loader program will typically write 0x01 to the CPUCS register to put the FX2's CPU into RESET, load all or part of the FX2's internal RAM with code, then reload the CPUCS register with 0 to take the CPU out of RESET.

---

## Chapter 3 Enumeration and ReNumeration™

---

### 3.1 Introduction

---

The FX2's configuration is *soft*. Code and data are stored in internal RAM, which can be loaded from the host over the USB interface. FX2-based USB peripherals can operate without ROM, EPROM, or FLASH memory, shortening production lead times and making firmware updates extremely simple.

To support this soft configuration, the FX2 is capable of enumerating as a USB device *without firmware*. This automatically-enumerated USB device (the *Default USB Device*) contains a set of interfaces and endpoints and can accept firmware downloaded from the host.



*Two separate Default USB Devices actually exist, one for enumeration as a full speed (12 Mbits/sec) device, and the other for enumeration as a high speed (480 Mbits/sec) device. The FX2 automatically performs the speed-detect protocol and chooses the proper Default USB Device. The two sets of Default USB Device descriptors are shown in Appendices A and B.*

Once the Default USB Device enumerates, it downloads firmware and descriptor tables from the host into the FX2's on-chip RAM. The FX2 then begins executing the downloaded code, which electrically simulates a physical disconnect/connect from the USB and causes the FX2 to enumerate again as a second device, this time taking on the USB personality defined by the downloaded code and descriptors. This patented secondary enumeration process is called "ReNumeration™."

An FX2 register bit called RENUM controls whether device requests over endpoint zero are handled by firmware or automatically by the Default USB Device. When RENUM=0, the Default USB Device handles the requests automatically; when RENUM=1, they must be handled by firmware.

---

### 3.2 FX2 Startup Modes

---

When the FX2 comes out of reset, it can act in various ways to establish itself as a USB device. FX2 power-on behavior depends on several factors:

1. If no off-chip memory (either on the I<sup>2</sup>C-compatible bus or on the address/data bus) is connected to the FX2, it enumerates as the Default USB Device, with descriptors and VID / PID / DID supplied by hardwired internal logic (Table 3-3). RENUM is set to 0, indicating that the Default USB Device automatically handles device requests.
2. If an EEPROM containing custom VID / PID / DID values is attached to the FX2's SCL and SDA pins, FX2 also enumerates as the Default USB Device as above, but it substitutes the VID / PID / DID values from the EEPROM for its internal values. The EEPROM must contain the value 0xC0 in its first byte to indicate this mode to FX2, so this mode is called a "C0 Load". As above, RENUM is automatically set to 0, indicating that the Default USB Device automatically handles device requests. A 16-byte EEPROM is sufficiently large for a C0 Load.
3. If an EEPROM containing FX2 firmware is attached to the SCL and SDA pins, the firmware is automatically loaded from the EEPROM into the FX2's on-chip RAM, and then the CPU is taken out of reset to execute this boot-loaded code. In this case, the VID / PID / DID values are encapsulated in the firmware; the RENUM bit is automatically set to 1 to indicate that the firmware, not the Default USB Device, handles device requests. The EEPROM must contain the value 0xC2 in its first byte to indicate this mode to FX2, so this mode is called a "C2 Load". *Although the FX2 can perform C2 Loads from EEPROMs as large as 64KB, code can only be downloaded to the 8K of on-chip RAM.*
4. If a Flash, EPROM, or other memory is attached to the FX2's address/data bus (128-pin package only) *and* a properly formatted EEPROM meeting the requirements above is *not* present, *and* the EA pin is tied high (indicating that the FX2 starts code execution at 0x0000 from off-chip memory), the FX2 begins executing firmware from the off-chip memory. In this case, the VID / PID / DID values are encapsulated in the firmware; the RENUM bit is automatically set to 1 to indicate that the firmware, not internal FX2 logic, handles device requests.

Case (2) is the most frequently used mode when soft operation is desired, since the VID/PID values from EEPROM always bind the device to the appropriate host driver while allowing FX2 firmware to be easily updated. In this case, the host first uses the FX2 Default USB Device to download firmware, then the host takes the CPU out of reset so that it can execute the downloaded code. Section 3.8, "FX2 Vendor Request for Firmware Load" describes the USB *Vendor Request* that the FX2 supports for code download and upload.



*The Default USB Device is fully characterized in Appendices A and B, which list the built-in FX2 descriptor tables for full-speed and high-speed enumeration, respectively. Studying these Appendices in conjunction with Tables 3-1 and 3-2 is an excellent way to learn the structure of USB descriptors.*

### 3.3 The Default USB Device

The Default USB Device consists of a single USB configuration containing one interface (interface 0) and alternate settings 0, 1, 2 and 3. The endpoints and MaxPacketSizes reported for this device are shown in Table 3-1 (full speed) and Table 3-2 (high speed). Note that alternate setting zero consumes no interrupt or isochronous bandwidth, as recommended by the USB Specification.

Table 3-1. Default Full-speed Alternate Settings

Alternate Setting	0	1	2	3
ep0	64	64	64	64
ep1out	0	64 bulk	64 int	64 int
ep1in	0	64 bulk	64 int	64 int
ep2	0	64 bulk out (2x)	64 int out (2x)	64 iso out (2x)
ep4	0	64 bulk out (2x)	64 bulk out (2x)	64 bulk out (2x)
ep6	0	64 bulk in (2x)	64 int in (2x)	64 iso in (2x)
ep8	0	64 bulk in (2x)	64 bulk in (2x)	64 bulk in (2x)

Note: "0" means "not implemented", "2x" means double buffered.

Table 3-2. Default High-speed Alternate Settings

Alternate Setting	0	1	2	3
ep0	64	64	64	64
ep1out	0	512 bulk	64 int	64 int
ep1in	0	512 bulk	64 int	64 int
ep2	0	512 bulk out (2x)	512 int out (2x)	512 iso out (2x)
ep4	0	512 bulk out (2x)	512 bulk out (2x)	512 bulk out (2x)
ep6	0	512 bulk in (2x)	512 int in (2x)	512 iso in (2x)
ep8	0	512 bulk in (2x)	512 bulk in (2x)	512 bulk in (2x)

Note: "0" means "not implemented", "2x" means double buffered.



Although the physical size of the EP1 endpoint buffer is 64 bytes, it is reported as a 512-byte buffer for high-speed alternate setting 1. This maintains compatibility with the USB 2.0 specification, which allows only 512-byte bulk endpoints. If you use this default alternate setting (for testing, for example), be sure to limit EP1 packet sizes to 64 bytes.

When FX2 logic establishes the Default USB Device shown in Table 3-1 or Table 3-2, it also sets the various endpoint configuration bits to match the descriptor data. For example, bulk endpoints 2, 4, and 6 are implemented in the Default USB Device, so the FX2 logic sets the corresponding EPVAL (Endpoint Valid) bits.

Chapter 8 "Access to Endpoint Buffers" contains a detailed explanation of the EPVAL bits.

## 3.4 EEPROM Boot-load Data Formats

This section describes three EEPROM boot-load scenarios and the EEPROM data formats that support them. The three scenarios are:

- No EEPROM, or EEPROM with invalid boot data
- “C0” EEPROM (load custom VID / PID / DID only)
- “C2” EEPROM (load firmware to on-chip RAM)

### 3.4.1 No EEPROM or Invalid EEPROM

In the simplest scenario, either no serial EEPROM is present on the I<sup>2</sup>C-compatible bus or an EEPROM is present, but its first byte is neither 0xC0 nor 0xC2. In this case, descriptor data is supplied by hardwired internal FX2 tables. The FX2 enumerates as the *Default USB Device*, with the ID bytes shown in Table 3-3.



*Pull-up resistors are required on the SCL/SDA pins even if no device is connected. The resistors are required to allow FX2 logic to detect the “No EEPROM / Invalid EEPROM” condition.*

Table 3-3. FX2 Device Characteristics, No EEPROM / Invalid EEPROM

<b>Vendor ID</b>	0x04B4 (Cypress Semiconductor/)
<b>Product ID</b>	0x8613 (EZ-USB FX2)
<b>Device Release</b>	0xXXYY (depends on revision)

The USB host queries the FX2 Default USB Device during enumeration, reads its device descriptor, and uses the IDs in Table 3-3 to determine which software driver to load into the operating system. This is a major USB feature — drivers are dynamically matched with devices and automatically loaded when a device is plugged in.

The “No EEPROM / Invalid EEPROM” scenario is the simplest configuration, and also the most limiting. This configuration must only be used for code development, utilizing Cypress software tools matched to the ID values in Table 3-3; *no USB peripheral based on the FX2 may use this configuration.*

### 3.4.2 Serial EEPROM Present, First Byte is 0xC0

Table 3-4. "C0 Load" Format

EEPROM Address	Contents
0	<b>0xC0</b>
1	Vendor ID (VID) L
2	Vendor ID (VID) H
3	Product ID (PID) L
4	Product ID (PID) H
5	Device ID (DID) L
6	Device ID (DID) H
7	Configuration byte

If, at power-on reset, the FX2 detects an EEPROM connected to its I<sup>2</sup>C-compatible bus with the value **0xC0** at address 0, the FX2 automatically copies the Vendor ID (VID), Product ID (PID), and Device ID (DID) from the EEPROM (Table 3-4) into internal storage. The FX2 then supplies these EEPROM bytes to the host as part of its response to the host's *Get\_Descriptor-Device* request (these six bytes replace only the VID / PID / DID bytes in the Default USB Device descriptor). This causes a host driver matched to the VID / PID / DID values in the EEPROM to be loaded by the host OS.

After initial enumeration, that host driver downloads FX2 firmware and USB descriptor data into the FX2's RAM and starts the CPU. The FX2 then ReNumerates™ as a custom device. At that point, the host may load a new driver, bound to the just-loaded VID / PID / DID.

The eighth EEPROM byte contains configuration bits that control the following:

- I<sup>2</sup>C-compatible bus speed. *Default is 100 KHz.*
- Disconnect polarity. *Default is for FX2 to come out of reset connected to USB.*

FX2 firmware can change the I<sup>2</sup>C-compatible bus speed using control-register bits, so an EEPROM is not required in order to override the default setting. However, the firmware cannot modify the disconnect polarity; if it's desired for the FX2 to come out of reset disconnected from USB, a "C0" or "C2" EEPROM must be connected.



Section 3.5 "EEPROM Configuration Byte" contains a full description of the configurations bits.

### 3.4.3 Serial EEPROM Present, First Byte is 0xC2

If, at power-on reset, the FX2 detects an EEPROM connected to its I<sup>2</sup>C-compatible with the value **0xC2** at address 0, the FX2 loads the EEPROM data into RAM. It also sets the RENUM bit to 1, causing device requests to be handled by the firmware instead of the Default USB Device. The “C2 Load” EEPROM data format is shown in Table 3-5.

Table 3-5. “C2 Load” Format

EEPROM Address	Contents
0	<b>0xC2</b>
1	Vendor ID (VID) L
2	Vendor ID (VID) H
3	Product ID (PID) L
4	Product ID (PID) H
5	Device ID (DID) L
6	Device ID (DID) H
7	Configuration byte
8	Length H
9	Length L
10	Start Address H
11	Start Address L
---	Data Block
---	
---	Length H
---	Length L
---	Start Address H
---	Start Address L
---	Data Block
---	
---	0x80
---	0x01
---	0xE6
---	0x00
last	00000000

The first byte indicates a “C2 load”, which instructs the FX2 to copy the EEPROM data into RAM. The FX2 reads the next six bytes (VID / PID / DID) even though they aren’t used by most C2-Load applications. The eighth byte (byte 7) is the configuration byte described in the previous section.





Bytes 1-6 of a C2 EEPROM can be loaded with VID / PID / DID bytes if it is desired at some point to run the firmware with  $RENUM = 0$  (i.e., FX2 logic handles device requests), using the EEPROM VID / PID / DID rather than the development-only VID / PID / DID values shown in Table 3-3.

One or more data records follow, starting at EEPROM address 8. Each data record consists of a 10-bit Length field (0-1023) which indicates the number of bytes in the following data block, a 13-bit Start Address (0-0x1FFF) for the data block, and the data block itself.

The last data record, which must always consist of a single-byte load of 0x00 to the CPUCS register at 0xE600, is marked with a "1" in the most-significant bit of the Length field. Only the least-significant bit (8051RES) of this byte is writable by the download; that bit is set to zero to bring the CPU out of reset.



Serial EEPROM data can be loaded only into these three **on-chip** RAM spaces:

- Program / Data RAM at 0x0000-0x1FFF
- Data RAM at 0xE000-0xE1FF
- The CPUCS register at 0xE600 (only bit 0, 8051RES, is EEPROM-loadable).

### **General-Purpose Use of the I<sup>2</sup>C-Compatible Bus**

The FX2's I<sup>2</sup>C-compatible controller serves two purposes. First, as described in this chapter, it manages the serial EEPROM interface that operates automatically at power-on to determine the enumeration method. Second, once the CPU is up and running, firmware can access the I<sup>2</sup>C-compatible controller for general-purpose use. This makes a wide range of standard I<sup>2</sup>C peripherals available to an FX2-based system.

Other I<sup>2</sup>C devices can be attached to the SCL and SDA lines as long as there is no address conflict with the serial EEPROM described in this chapter. Chapter 13, "Input/Output" describes the general-purpose nature of the I<sup>2</sup>C-compatible interface.

### 3.5 EEPROM Configuration Byte

The configuration byte is valid for both EEPROM load formats (C0 and C2) and has the following format:

Configuration							
b7	b6	b5	b4	b3	b2	b1	b0
0	DISCON	0	0	0	0	0	400KHz

Figure 3-1. EEPROM Configuration Byte

**Bit 6:**                    **DISCON**                    *USB Disconnect*

A USB hub or host detects attachment of a full-speed device by sensing a high level on the D+ wire. A USB device provides this high level using a 1500-ohm resistor between D+ and 3.3V (the D+ line is normally low, pulled down by a 15 K-ohm resistor in the hub or host). The 1500-ohm resistor is internal to the FX2.

The FX2 accomplishes ReNumeration by selectively driving or floating the 3.3V supply to its internal 1500-ohm resistor. When the supply is floated, the host no longer “sees” the FX2; it appears to have been disconnected from the USB. When the supply is then driven, the FX2 appears to have been newly-connected to the USB. From the host’s point of view, the FX2 can be disconnected and re-connected to the USB, without ever *physically* disconnecting.

The “connect state” of FX2 is controlled by a register bit called DISCON (USBCS.3), which defaults to 0, or “connected”. This default may be overridden by setting the **DISCON** bit in the EEPROM configuration byte to 1. This bit is copied into the USBCS.3 bit before the CPU is taken out of reset. Once the CPU is running, firmware can modify this bit.

**Bit 0:**                    **400KHz**                    *I<sup>2</sup>C-compatible bus speed*

0: 100 KHz

1: 400 KHz

If 400KHZ=0, the I<sup>2</sup>C-compatible bus operates at approximately 100 KHz. If 400KHZ=1, the I<sup>2</sup>C-compatible bus operates at approximately 400 KHz. This bit is copied to I<sup>2</sup>CCTL.0, whose default value is 0, or “100 KHz”. Once the CPU is running, firmware can modify this bit.

---

## 3.6 The RENUM Bit

---

An FX2 control bit called “RENUM” (ReNumerated) determines whether USB device requests over endpoint zero are handled by the Default USB Device or by FX2 firmware. At power-on reset, the RENUM bit (USBCS.1) is zero, indicating that the Default USB Device will automatically handle USB device requests. Once firmware has been downloaded to the FX2 and the CPU is running, it can set RENUM=1 so that subsequent device requests will be handled by the downloaded firmware and descriptor tables. *Chapter 2, “Endpoint Zero”* describes how the firmware handles device requests while RENUM=1.

If a 128-pin FX2 is using off-chip code memory at 0x0000 and there is no boot EEPROM to supply a custom Vendor ID and Product ID, the FX2 automatically sets the RENUM bit to 1 so that device requests are always handled by the firmware and descriptor tables in the off-chip memory. The FX2 also sets RENUM=1 after a “C2 load” if the EA pin is low. In this case, firmware execution begins in internal RAM using the code loaded from the EEPROM, with the firmware handling all USB requests.

### **Another Use for the Default USB Device**

*The Default USB Device is established at power-on to set up a USB device capable of downloading firmware into the FX2’s RAM. Another useful feature of the Default USB Device is that FX2 code can be written to support the already-configured generic USB device. Before bringing the CPU out of reset, the FX2 automatically enables certain endpoints and reports them to the host via descriptors. By utilizing the Default USB Device (i.e., by keeping RENUM=0), the firmware can, with very little code, perform meaningful USB transfers that use these pre-configured endpoints. This accelerates the USB learning curve.*

### 3.7 FX2 Response to Device Requests (RENUM=0)

Table 3-6 shows how the Default USB Device responds to endpoint zero device requests when RENUM=0.

Table 3-6. How the Default USB Device Handles EP0 Requests When RENUM=0

bRequest	Name	FX2 Response
0x00	Get Status-Device	Returns two zero bytes
0x00	Get Status-Endpoint	Supplies EP Stall bit for indicated EP
0x00	Get Status-Interface	Returns two zero bytes
0x01	Clear Feature-Device	None
0x01	Clear Feature-Endpoint	Clears Stall bit for indicated EP
0x02	(reserved)	None
0x03	Set Feature-Device	None
0x03	Set Feature-Endpoint	Sets Stall bit for indicated EP
0x04	(reserved)	None
0x05	Set Address	Updates FNADD register
0x06	Get Descriptor	Supplies internal table
0x07	Set Descriptor	None
0x08	Get Configuration	Returns internal value
0x09	Set Configuration	Sets internal value
0x0A	Get Interface	Returns internal value (0-3)
0x0B	Set Interface	Sets internal value (0-3)
0x0C	Sync Frame	None
<b>Vendor Requests</b>		
0xA0	Firmware Load	Upload/Download RAM
0xA1-0xAF	Reserved	Reserved by Cypress Semiconductor
all other		None

A USB host enumerates by issuing *Set\_Address*, *Get\_Descriptor*, and *Set\_Configuration* (to 1) requests (the *Set\_Address* and *Get\_Address* requests are used **only** during enumeration). After enumeration, the Default USB Device will respond to the following device requests from the host:

- Set or clear an endpoint stall (*Set/Clear Feature\_Endpoint*)
- Read the stall status for an endpoint (*Get\_Status-Endpoint*)
- Set/Read an 8-bit configuration number (*Set/Get\_Configuration*)
- Set/Read a 2-bit interface alternate setting (*Set/Get\_Interface*)
- Download or upload FX2 RAM

### 3.8 FX2 Vendor Request for Firmware Load

Prior to ReNumeration, the host downloads data into the FX2's internal RAM. The host can access two **on-chip** FX2 RAM spaces — Program / Data RAM at 0x0000-0x1FFF and Data RAM at 0xE000-0xE1FF — which it can download or upload whether the CPU is in reset or running: These two RAM spaces may also be boot-loaded by a “C2” EEPROM connected to the I<sup>2</sup>C-compatible bus. The host may also write to the CPUCS register to put the CPU in or out of reset.

*Off-chip RAM (on the 128-pin FX2's address/data bus) cannot be uploaded or downloaded by the host via the “Firmware Load” vendor request.*

The USB Specification provides for *vendor-specific requests* to be sent over endpoint zero. The FX2 uses this feature to transfer data between the host and FX2 RAM. The FX2 automatically responds to two “Firmware Load” requests, as shown in Table 3-7 and Table 3-8.

Table 3-7. Firmware Download

Byte	Field	Value	Meaning	FX2 Response
0	bmRequest	<b>0x40</b>	Vendor Request, OUT	None required
1	bRequest	<b>0xA0</b>	“Firmware Load”	
2	wValueL	<b>AddrL</b>	Starting Address	
3	wValueH	<b>AddrH</b>		
4	wIndexL	0x00		
5	wIndexH	0x00		
6	wLengthL	<b>LenL</b>	Number of Bytes	
7	wLengthH	<b>LenH</b>		

Table 3-8. Firmware Upload

Byte	Field	Value	Meaning	FX2 Response
0	bmRequest	<b>0xC0</b>	Vendor Request, IN	None required
1	bRequest	<b>0xA0</b>	“Firmware Load”	
2	wValueL	<b>AddrL</b>	Starting Address	
3	wValueH	<b>AddrH</b>		
4	wIndexL	0x00		
5	wIndexH	0x00		
6	wLengthL	<b>LenL</b>	Number of Bytes	
7	wLengthH	<b>LenH</b>		

These upload and download requests are always handled by the FX2, **regardless** of the state of the RENUM bit.

The bRequest value 0xA0 is reserved for this purpose. It should never be used for another vendor request. Cypress Semiconductor also reserves bRequest values 0xA1 through 0xAF; devices should not use these bRequest values.

A host loader program will typically write 0x01 to the CPUCS register to put the CPU into RESET, load all or part of the FX2 RAM with firmware, then reload the CPUCS register with 0 to take the CPU out of RESET. The CPUCS register (at 0xE600) is the only FX2 register that can be written using the Firmware Download command.

---

### 3.9 How the Firmware ReNumerates

---

Two control bits in the USBCS (USB Control and Status) register control the ReNumeration™ process: DISCON and RENUM.

USBCS		USB Control and Status				E680	
b7	b6	b5	b4	b3	b2	b1	b0
HSM	0	0	0	DISCON	NOSYNSOF	RENUM	SIGRSUME
R/W	R	R	R	R/W	R/W	R/W	R/W
0	0	0	0	0	1	0	0

Figure 3-2. USB Control and Status Register

To simulate a USB disconnect, the firmware sets DISCON to 1. To reconnect, the firmware clears DISCON to 0.

Before reconnecting, the firmware sets or clears the RENUM bit to indicate whether the firmware or the Default USB Device will handle device requests over endpoint zero: if RENUM=0, the Default USB Device will handle device requests; if RENUM=1, the firmware will.

---

### 3.10 Multiple ReNumerations™

---

FX2 firmware can ReNumerate™ anytime. One use for this capability might be to *fine tune* an isochronous endpoint's bandwidth requests by trying various descriptor values and ReNumerating.

## Chapter 4 Interrupts

### 4.1 Introduction

The EZ-USB FX2's interrupt architecture is an enhanced and expanded version of the standard 8051's. The FX2 responds to the interrupts shown in Table 4-1; interrupt sources that are not present in the standard 8051 are shown in **bold** type.

Table 4-1. FX2 Interrupts

FX2 Interrupt	Source	Interrupt Vector	Natural Priority
IE0	INT0 Pin	0x0003	1
TF0	Timer 0 Overflow	0x000B	2
IE1	INT1 Pin	0x0013	3
TF1	Timer 1 Overflow	0x001B	4
RI_0 & TI_0	UART0 Rx & Tx	0x0023	5
<b>TF2</b>	<b>Timer 2 Overflow</b>	0x002B	6
<b>Resume</b>	<b>WAKEUP / WU2 Pin or USB Resume</b>	0x0033	0
RI_1 & TI_1	UART1 Rx & Tx	0x003B	7
<b>USBINT</b>	<b>USB</b>	0x0043	8
<b>PCINT</b>	<b>PC-Compatible Bus</b>	0x004B	9
<b>IE4</b>	<b>GPIF / FIFOs / INT4 Pin</b>	0x0053	10
<b>IE5</b>	<b>INT5 Pin</b>	0x005B	11
<b>IE6</b>	<b>INT6 Pin</b>	0x0063	12

The **Natural Priority** column in Table 4-1 shows the FX2 interrupt priorities. As explained in *Chapter 14, "Timers/Counters and Serial Interface"*, the FX2 can assign each interrupt to a high or low priority group. The FX2 resolves priorities within the groups using the natural priorities.

## 4.2 SFRs

The following SFRs are associated with interrupt control:

- IE - SFR 0xA8 (Table 4-2)
- IP - SFR 0xB8 (Table 4-3)
- EXIF - SFR 0x91 (Table 4-4)
- EICON - SFR 0xD8 (Table 4-5)
- EIE - SFR 0xE8 (Table 4-6)
- EIP - SFR 0xF8 (Table 4-7)

The IE and IP SFRs provide interrupt enable and priority control for the standard interrupt unit, as with the standard 8051. Additionally, these SFRs provide control bits for the Serial Port 1 interrupt.

The EXIF, EICON, EIE and EIP Registers provide flags, enable control, and priority control.

Table 4-2. IE Register — SFR 0xA8

Bit	Function
IE.7	<b>EA</b> - Global interrupt enable. Controls masking of all interrupts except USB wakeup (resume). EA = 0 disables all interrupts except USB wakeup. When EA = 1, interrupts are enabled or masked by their individual enable bits.
IE.6	<b>ES1</b> - Enable Serial Port 1 interrupt. ES1 = 0 disables Serial port 1 interrupts (TI_1 and RI_1). ES1 = 1 enables interrupts generated by the TI_1 or RI_1 flag.
IE.5	<b>ET2</b> - Enable Timer 2 interrupt. ET2 = 0 disables Timer 2 interrupt (TF2). ET2=1 enables interrupts generated by the TF2 or EXF2 flag.
IE.4	<b>ES0</b> - Enable Serial Port 0 interrupt. ES0 = 0 disables Serial Port 0 interrupts (TI_0 and RI_0). ES0=1 enables interrupts generated by the TI_0 or RI_0 flag.
IE.3	<b>ET1</b> - Enable Timer 1 interrupt. ET1 = 0 disables Timer 1 interrupt (TF1). ET1=1 enables interrupts generated by the TF1 flag.
IE.2	<b>EX1</b> - Enable external interrupt 1. EX1 = 0 disables external interrupt 1 (INT1). EX1=1 enables interrupts generated by the $\overline{\text{INT1}}$ pin.
IE.1	<b>ET0</b> - Enable Timer 0 interrupt. ET0 = 0 disables Timer 0 interrupt (TF0). ET0=1 enables interrupts generated by the TF0 flag.
IE.0	<b>EX0</b> - Enable external interrupt 0. EX0 = 0 disables external interrupt 0 (INT0). EX0=1 enables interrupts generated by the $\overline{\text{INT0}}$ pin.



Table 4-3. IP Register — SFR 0xB8

Bit	Function
IP.7	<b>Reserved.</b> Read as 1.
IP.6	<b>PS1</b> - Serial Port 1 interrupt priority control. PS1 = 0 sets Serial Port 1 interrupt (TI_1 or RI_1) to low priority. PS1 = 1 sets Serial port 1 interrupt to high priority.
IP.5	<b>PT2</b> - Timer 2 interrupt priority control. PT2 = 0 sets Timer 2 interrupt (TF2) to low priority. PT2 = 1 sets Timer 2 interrupt to high priority.
IP.4	<b>PS0</b> - Serial Port 0 interrupt priority control. PS0 = 0 sets Serial Port 0 interrupt (TI_0 or RI_0) to low priority. PS0 = 1 sets Serial Port 0 interrupt to high priority.
IP.3	<b>PT1</b> - Timer 1 interrupt priority control. PT1 = 0 sets Timer 1 interrupt (TF1) to low priority. PT1 = 1 sets Timer 1 interrupt to high priority.
IP.2	<b>PX1</b> - External interrupt 1 priority control. PX1 = 0 sets external interrupt 1 (INT1) to low priority. PT1 = 1 sets external interrupt 1 to high priority.
IP.1	<b>PT0</b> - Timer 0 interrupt priority control. PT0 = 0 sets Timer 0 interrupt (TF0) to low priority. PT0 = 1 sets Timer 0 interrupt to high priority.
IP.0	<b>PX0</b> - External interrupt 0 priority control. PX0 = 0 sets external interrupt 0 (INT0) to low priority. PX0 = 1 sets external interrupt 0 to high priority.

Table 4-4. EXIF Register — SFR 0x91

Bit	Function
EXIF.7	<b>IE5</b> - External Interrupt 5 flag. IE5 = 1 indicates a falling edge was detected at the INT5 pin. IE5 must be cleared by software. Setting IE5 in software generates an interrupt, if enabled.
EXIF.6	<b>IE4</b> - GPIF/FIFO/External Interrupt 4 flag. The “INT4” interrupt is internally connected to the FIFO/GPIF interrupt by default; it can optionally function as External Interrupt 4 on the 100- and 128-pin FX2. When configured as External Interrupt 4, IE4 indicates that a rising edge was detected at the INT4 pin. IE4 must be cleared by software. Setting IE4 in software generates an interrupt, if enabled.
EXIF.5	<b>I<sup>2</sup>CINT</b> - I <sup>2</sup> C-Compatible Bus Interrupt flag. I <sup>2</sup> CINT = 1 indicates an I <sup>2</sup> C-Compatible Bus interrupt. I <sup>2</sup> CINT must be cleared by software. Setting I <sup>2</sup> CINT in software generates an interrupt, if enabled.
EXIF.4	<b>USBINT</b> - USB Interrupt flag. USBINT = 1 indicates an USB interrupt. USBINT must be cleared by software. Setting USBINT in software generates an interrupt, if enabled.
EXIF.3	<b>Reserved.</b> Read as 1.
EXIF.2-0	<b>Reserved.</b> Read as 0.

Table 4-5. EICON Register — SFR 0xD8

Bit	Function
EICON.7	<b>SMOD1</b> - Serial Port 1 baud rate doubler enable. When SMOD1 = 1, the baud rate for Serial Port 1 is doubled.
EICON.6	<b>Reserved.</b> Read as 1.
EICON.5	<b>ERESI</b> - Enable Resume interrupt. ERESI = 0 disables the Resume interrupt. ERESI = 1 enables interrupts generated by the resume event.
EICON.4	<b>RESI</b> - Wakeup interrupt flag. RESI = 1 indicates a false-to-true transition was detected at the WAKEUP or WU pin, or that USB activity has resumed from the suspended state. RESI must be cleared by software before exiting the interrupt service routine, otherwise the interrupt will immediately be reasserted. Setting RESI = 1 in software generates a wakeup interrupt, if enabled.
EICON.3	<b>INT6</b> - External interrupt 6. When INT6 = 1, the INT6 pin has detected a low to high transition. INT6 must be cleared by software. Setting this bit in software generates an INT6 interrupt, if enabled.
EICON.2-0	<b>Reserved.</b> Read as 0.

Table 4-6. EIE Register — SFR 0xE8

Bit	Function
EIE.7-5	Reserved. Read as 1.
EIE.4	<b>EX6</b> - Enable external interrupt 6. EX6 = 0 disables external interrupt 6 (INT6). EX6 = 1 enables interrupts generated by the INT6 pin.
EIE.3	<b>EX5</b> - Enable external interrupt 5. EX5 = 0 disables external interrupt 5 (INT5). EX5 = 1 enables interrupts generated by the INT5 pin.
EIE.2	<b>EX4</b> - Enable external interrupt 4. EX4 = 0 disables external interrupt 4 (INT4). EX4 = 1 enables interrupts generated by the INT4 pin or by the FIFO/GPIF Interrupt.
EIE.1	<b>EI<sup>2</sup>C</b> - Enable I <sup>2</sup> C-Compatible Bus interrupt (I <sup>2</sup> CINT). EI <sup>2</sup> C = 0 disables the I <sup>2</sup> C-Compatible Bus interrupt. EI <sup>2</sup> C = 1 enables interrupts generated by the I <sup>2</sup> C-Compatible Bus controller.
EIE.0	<b>EUSB</b> - Enable USB interrupt (USBINT). EUSB = 0 disables USB interrupts. EUSB = 1 enables interrupts generated by the USB Interface.

Table 4-7. EIP Register — SFR 0xF8

Bit	Function
EIP.7-5	<b>Reserved.</b> Read as 1.
EIP.4	<b>PX6</b> - External interrupt 6 priority control. PX6 = 0 sets external interrupt 6 (INT6) to low priority. PX6 = 1 sets external interrupt 6 to high priority.
EIP.3	<b>PX5</b> - External interrupt 5 priority control. PX5 = 0 sets external interrupt 5 (INT5) to low priority. PX5=1 sets external interrupt 5 to high priority.
EIP.2	<b>PX4</b> - External interrupt 4 priority control. PX4 = 0 sets external interrupt 4 (INT4 / GPIF / FIFO) to low priority. PX4=1 sets external interrupt 4 to high priority.
EIP.1	<b>PI<sup>2</sup>C</b> - I <sup>2</sup> CINT priority control. PI <sup>2</sup> C = 0 sets I <sup>2</sup> C-Compatible Bus interrupt to low priority. PI <sup>2</sup> C=1 sets I <sup>2</sup> C-Compatible Bus interrupt to high priority.
EIP.0	<b>PUSB</b> - USBINT priority control. PUSB = 0 sets USB interrupt to low priority. PUSB=1 sets USB interrupt to high priority.

### 4.2.1 803x/805x Compatibility

The implementation of interrupts is similar to that of the Dallas Semiconductor DS80C320. Table 4-8 summarizes the differences in interrupt implementation between the Intel 8051, the Dallas Semiconductor DS80C320, and the FX2.

Table 4-8. Summary of Interrupt Compatibility

Feature	Intel 8051	Dallas DS80C320	Cypress FX2
Power Fail Interrupt	Not implemented	Internally generated	Replaced with RESUME Interrupt
External Interrupt 0	Implemented	Implemented	Implemented
Timer 0 Interrupt	Implemented	Implemented	Implemented
External Interrupt 1	Implemented	Implemented	Implemented
Timer 1 Interrupt	Implemented	Implemented	Implemented
Serial Port 0 Interrupt	Implemented	Implemented	Implemented
Timer 2 Interrupt	Not implemented	Implemented	Implemented
Serial Port 1 Interrupt	Not implemented	Implemented	Implemented
External Interrupt 2	Not implemented	Implemented	Replaced with autovectorized USB Interrupt
External Interrupt 3	Not implemented	Implemented	Replaced with I <sup>2</sup> C-Compatible Bus Interrupt
External Interrupt 4	Not implemented	Implemented	Replaced by autovectorized FIFO/GPIF Interrupt. Can be configured as External Interrupt 4 on 100- and 128-pin FX2 only.
External Interrupt 5	Not implemented	Implemented	Implemented
Watchdog Timer Interrupt	Not implemented	Internally generated	Replaced with External Interrupt 6
Real-time Clock Interrupt	Not implemented	Implemented	Not implemented

---

## 4.3 Interrupt Processing

---

When an enabled interrupt occurs, the FX2 completes the instruction it's currently executing, then vectors to the address of the interrupt service routine (ISR) associated with that interrupt (see Table 4-9). The FX2 executes the ISR to completion unless another interrupt of higher priority occurs. Each ISR ends with a `RETI` (return from interrupt) instruction. After executing the `RETI`, the FX2 continues executing firmware at the instruction following the one which was executing when the interrupt occurred.



*The FX2 always completes the instruction in progress before servicing an interrupt. If the instruction in progress is `RETI`, or a write access to any of the `IP`, `IE`, `EIP`, or `EIE` SFRs, the FX2 completes one additional instruction before servicing the interrupt.*

---

### 4.3.1 Interrupt Masking

The EA Bit in the IE SFR (IE.7) is a global enable for all interrupts except the RESUME (USB wakeup) interrupt, which is always enabled. When EA = 1, each interrupt is enabled or masked by its individual enable bit. When EA = 0, all interrupts are masked except the USB wakeup interrupt.

Table 4-9 provides a summary of interrupt sources, flags, enables, and priorities.

Table 4-9. Interrupt Flags, Enables, Priority Control, and Vectors

Interrupt	Description	Interrupt Request Flag	Interrupt Enable	Assigned Priority Control	Natural Priority	Interrupt Vector
RESUME	Resume interrupt	EICON.4	EICON.5	Always Highest	0 (highest)	0x0033
INT0	External interrupt 0	TCON.1	IE.0	IP.0	1	0x0003
TF0	Timer 0 interrupt	TCON.5	IE.1	IP.1	2	0x000B
INT1	External interrupt 1	TCON.3	IE.2	IP.2	3	0x0013
TF1	Timer 1 interrupt	TCON.7	IE.3	IP.3	4	0x001B
TI_0 or RI_0	Serial port 0 transmit or receive interrupt	SCON0.1 (TI_0) SCON0.0 (RI_0)	IE.4	IP.4	5	0x0023
TF2 or EXF2	Timer 2 interrupt	T2CON.7 (TF2) T2CON.6 (EXF2)	IE.5	IP.5	6	0x002B
TI_1 or RI_1	Serial port 1 transmit or receive interrupt	SCON1.1 (TI_1) SCON1.0 (RI_1)	IE.6	IP.6	7	0x003B
USBINT	Autovectorized USB interrupt	EXIF.4	EIE.0	EIP.0	8	0x0043
I <sup>2</sup> CINT	I <sup>2</sup> C-Compatible Bus interrupt	EXIT.5	EIE.1	EIP.1	9	0x004B
INT4	Autovectorized FIFO / GPIF or External interrupt 4	EXIF.6	EIE.2	EIP.2	10	0x0053
INT5	External interrupt 5	EXIF.7	EIE.3	EIP.3	11	0x005B
INT6	External interrupt 6	EICON.3	EIE.4	EIP.4	12	0x0063

### 4.3.1.1 Interrupt Priorities

There are two stages of interrupt priority: assigned interrupt level and natural priority. Assigned priority is set by FX2 firmware; natural priority is as shown in Table 4-9, and is fixed.

*The assigned interrupt level (highest, high, or low) takes precedence over natural priority. The RESUME (USB wakeup) interrupt always has highest assigned priority and is the only interrupt that can have highest assigned priority. All other interrupts can be assigned either high or low priority.*

In addition to an assigned priority level (high or low), each interrupt also has a natural priority, as listed in Table 4-9. *Simultaneous* interrupts with the same assigned priority level (for example, both high) are resolved according to their natural priority. For example, if INT0 and INT1 are both assigned high priority and both occur simultaneously, INT0 takes precedence due to its higher natural priority.

Once an interrupt is being serviced, only an interrupt of higher *assigned* priority level can interrupt the service routine. That is, an ISR for a low-assigned-level interrupt can only be interrupted by a high-assigned-level interrupt. An ISR for a high-assigned-level interrupt can only be interrupted by the RESUME interrupt.

---

### 4.3.2 Interrupt Sampling

The internal timers and serial ports generate interrupts by setting the interrupt flag bits shown in Table 4-9. These interrupts are sampled once per instruction cycle (i.e., once every 4 CLKOUT cycles).

INT0 and INT1 are both active low and can be programmed to be either edge-sensitive or level-sensitive, through the IT0 and IT1 bits in the TCON SFR. When  $IT_x = 0$ ,  $INT_x$  is level-sensitive and the FX2 sets the IEx flag when the  $\overline{INT_x}$  pin is sampled low. When  $IT_x = 1$ ,  $INT_x$  is edge-sensitive and the FX2 sets the IEx flag when the  $\overline{INT_x}$  pin is sampled high then low on consecutive samples.

The remaining five interrupts (INT 4-6, USB & I<sup>2</sup>C-Compatible Bus interrupts) are edge-sensitive only. INT6 and INT4 are active high and INT5 is active low.

To ensure that edge-sensitive interrupts are detected, the interrupt pins should be held in each state for a minimum of one instruction cycle (4 CLKOUT cycles). Level-sensitive interrupts are not latched; their pins must remain asserted until the interrupt is serviced.

---

### 4.3.3 Interrupt Latency

Interrupt response time depends on the current state of the FX2. The fastest response time is 5 instruction cycles: 1 to detect the interrupt, and 4 to perform the LCALL to the ISR.

The maximum latency is 13 instruction cycles. This 13-cycle latency occurs when the FX2 is currently executing a RETI instruction followed by a MUL or DIV instruction. The 13 instruction cycles in this case are: 1 to detect the interrupt, 3 to complete the RETI, 5 to execute the DIV or MUL, and 4 to execute the LCALL to the ISR.

This 13-instruction-cycle latency excludes autovector latency for the USB and FIFO/GPIF interrupts (see Sections 4.5 and 4.8). Autovectoring adds a fixed 4 instruction cycles, so the maximum latency for an autovectored USB or FIFO/GPIF interrupt is  $13 + 4 = 17$  instruction cycles.

---

## 4.4 USB-Specific Interrupts

---

The FX2 provides 28 USB-specific interrupts. One, "Resume", has its own dedicated interrupt; the other 27 share the "USB" interrupt.

---

### 4.4.1 Resume Interrupt

After the FX2 has entered its idle state, it responds to an external signal on its WAKEUP/WU2 pins or resumption of USB bus activity by restarting its oscillator and resuming firmware execution.

*Chapter 6, "Power Management"* describes suspend/resume signaling in detail, and presents an example which uses the Wakeup Interrupt.

## 4.4.2 USB Interrupts

Table 4-10 shows the 27 USB requests that share the USB Interrupt. Figur e4-1 shows the USB Interrupt logic; the bottom IRQ, EP8ISOERR, is expanded in the diagram to show the logic which is associated with each USB interrupt request.

Table 4-10. Individual USB Interrupt Sources

Priority	INT2VEC Value	Source	Notes
1	00	SUDAV	SETUP Data Available
2	04	SOF	Start of Frame (or microframe)
3	08	SUTOK	Setup Token Received
4	0C	SUSPEND	USB Suspend request
5	10	USB RESET	Bus reset
6	14	HISPEED	Entered high speed operation
7	18	EP0ACK	FX2 ACK'd the CONTROL Handshake
8	1C	reserved	
9	20	EP0-IN	EP0-IN ready to be loaded with data
10	24	EP0-OUT	EP0-OUT has USB data
11	28	EP1-IN	EP1-IN ready to be loaded with data
12	2C	EP1-OUT	EP1-OUT has USB data
13	30	EP2	IN: buffer available. OUT: buffer has data
14	34	EP4	IN: buffer available. OUT: buffer has data
15	38	EP6	IN: buffer available. OUT: buffer has data
16	3C	EP8	IN: buffer available. OUT: buffer has data
17	40	IBN	IN-Bulk-NAK (any IN endpoint)
18	44	reserved	
19	48	EP0PING	EP0 OUT was Pinged and it NAK'd
20	4C	EP1PING	EP1 OUT was Pinged and it NAK'd
21	50	EP2PING	EP2 OUT was Pinged and it NAK'd
22	54	EP4PING	EP4 OUT was Pinged and it NAK'd
23	58	EP6PING	EP6 OUT was Pinged and it NAK'd
24	5C	EP8PING	EP8 OUT was Pinged and it NAK'd
25	60	ERRLIMIT	Bus errors exceeded the programmed limit
26	64	reserved	
27	68	reserved	
28	6C	reserved	
29	70	EP2ISOERR	ISO EP2 OUT PID sequence error
30	74	EP4ISOERR	ISO EP4 OUT PID sequence error
31	78	EP6ISOERR	ISO EP6 OUT PID sequence error
32	7C	EP8ISOERR	ISO EP8 OUT PID sequence error

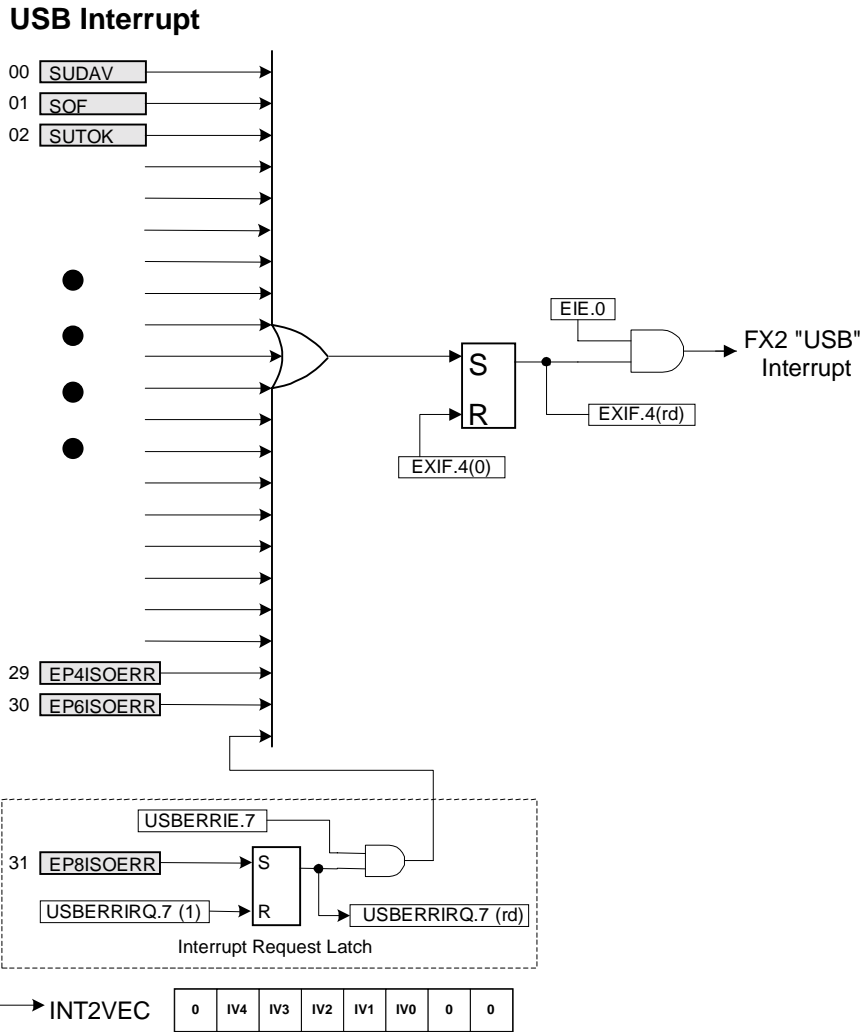

Figure 4-1. USB Interrupts

Referring to the logic inside the dotted lines, each USB interrupt source has an interrupt request latch. IRQ bits are set automatically by the FX2; firmware clears an IRQ bit by writing a “1” to it. The output of each latch is ANDed with an Interrupt Enable Bit and then ORed with all the other USB Interrupt request sources.

The FX2 prioritizes the USB interrupts and constructs an Autovector, which appears in the INT2VEC register. The interrupt vector values IV[4:0] are shown to the left of the interrupt sources (shaded boxes); 0 is the highest priority, 31 is the lowest. If two USB interrupts occur simultaneously, the prioritization affects which one is first indicated in the INT2VEC register.



If Autovectoring is enabled, the INT2VEC byte replaces the contents of address 0x0045 in the FX2's program memory. This causes the FX2 to automatically vector to a different address for each USB interrupt source. This mechanism is explained in detail in Section 4.5. "*USB-Interrupt Autovectors.*"

Due to the OR gate in Figure 4-1, assertion of any of the individual USB interrupt sources sets the FX2's "main" USB Interrupt request bit (EXIF.4). This main USB interrupt is enabled by setting EIE.0 to 1.

To clear the main USB interrupt request, firmware clears the EXIF.4 bit to 0.

After servicing a USB interrupt, FX2 firmware clears the individual USB source's IRQ bit by setting it to 1. If any other USB interrupts are pending, the act of clearing the IRQ bit causes the FX2 to generate another pulse for the highest-priority pending interrupt. If more than one is pending, each is serviced in the priority order shown in Figure 4-1, starting with SUDAV (priority 00) as the highest priority, and ending with EP8ISOERR (priority 31) as the lowest.



*The main USB interrupt request is cleared by **clearing** the EXIF.4 bit **to 0**; each individual USB interrupt is cleared by **setting** its IRQ bit **to 1**.*

#### ***Important***

It is important in any USB Interrupt Service Routine (ISR) to clear the main USB Interrupt **before** clearing the individual USB interrupt request latch. This is because as soon as the individual USB interrupt is cleared, any pending USB interrupt will immediately try to generate another main USB Interrupt. If the main USB IRQ bit has not been previously cleared, the pending interrupt will be lost.

Figure 4-2 illustrates a typical USB ISR for endpoint 2-IN.

```

USB_ISR:  push  dps
          push  dpl
          push  dph
          push  dp11
          push  dph1
          push  acc
;
          mov   a,EXIF           ; FIRST clear the USB (INT2) interrupt request
          clr   acc.4
          mov   EXIF,a           ; Note: EXIF reg is not bit-addressable
;
          mov   dptr,#USBERRIRQ ; now clear the USB interrupt request
          mov   a,#10000000b     ; use EP8ISOERR as example
          movx  @dptr,a
;
; (service the interrupt here)
;
          pop   acc
          pop   dph1
          pop   dp11
          pop   dph
          pop   dpl
          pop   dps
;
          reti

```

Figure 4-2. The Order of Clearing Interrupt Requests is Important

The registers associated with the individual USB interrupt sources are described in *Chapter 15, "Registers"* and Section 8.6, "CPU Control of FX2 Endpoints". Each interrupt source has an enable (IE) and a request (IRQ) bit. Firmware sets the IE bit to 1 to enable the interrupt. The FX2 sets an IRQ bit to 1 to request an interrupt, and the firmware clears an IRQ bit by writing a "1" to it.

#### 4.4.2.1 SUTOK, SUDAV Interrupts

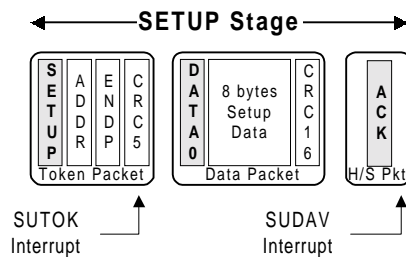

Figure 4-3. SUTOK and SUDAV Interrupts

SUTOK and SUDAV are supplied to the FX2 by CONTROL endpoint zero. The first portion of a USB CONTROL transfer is the SETUP stage shown in Figure 4-3 (a full CONTROL transfer is shown in Figure 2-1). When the FX2 decodes a SETUP packet, it asserts the SUTOK (SETUP Token) Interrupt Request. After the FX2 has received the eight bytes error-free and copied them into the eight internal registers at SETUPDAT, it asserts the SUDAV Interrupt Request.

Firmware responds to the SUDAV Interrupt by reading the eight SETUP data bytes in order to decode the USB request (*Chapter 2, "Endpoint Zero"*).

The SUTOK Interrupt is provided to give advance warning that the eight register bytes at SETUPDAT are about to be overwritten. It is useful for debug and diagnostic purposes.

#### 4.4.2.2 SOF Interrupt

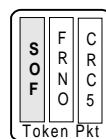

Figure 4-4. A Start Of Frame (SOF) Packet

A USB Start-of-Frame Interrupt Request is asserted when the host sends a Start of Frame (SOF) packet. SOFs occur once per millisecond in full-speed (12 Mbits/sec) mode, and once every 125 microseconds in high-speed (480 Mbits/sec) mode.

When the FX2 receives an SOF packet, it copies the eleven-bit frame number (FRNO in Figure 4-4) into the USBFRAMEH:L registers and asserts the SOF Interrupt Request. All isochronous endpoint data is generally serviced via the SOF Interrupt.

#### 4.4.2.3 Suspend Interrupt

If the FX2 detects a “suspend” condition from the host, it asserts the SUSP (Suspend) Interrupt Request. A full description of Suspend-Resume signaling appears in *Chapter 6, "Power Management"*.

#### 4.4.2.4 USB RESET Interrupt

The USB host signals a bus reset by driving both D+ and D- low for at least 10 ms. When the FX2 detects the onset of USB bus reset, it asserts the URES Interrupt Request.

#### 4.4.2.5 HISPEED Interrupt

This interrupt is asserted when the host grants high-speed (480 Mbps) access to the FX2.

#### 4.4.2.6 EP0ACK Interrupt

This interrupt is asserted when the FX2 has acknowledged the STATUS stage of a CONTROL transfer on endpoint 0.

#### 4.4.2.7 Endpoint Interrupts

These interrupts are asserted when an endpoint requires service.

For an OUT endpoint, the interrupt request signifies that OUT data has been sent from the host, validated by the FX2, and is in the endpoint buffer memory.

For an IN endpoint, the interrupt request signifies that the data previously loaded by the FX2 into the IN endpoint buffer has been read and validated by the host, making the IN endpoint buffer ready to accept new data.

*Table 4-11. Endpoint Interrupts*

EP0-IN	EP0-IN ready to be loaded with data (BUSY bit 1-to-0)
EP0-OUT	EP0-OUT has received USB data (BUSY bit 1-to-0)
EP1-IN	EP1-IN ready to be loaded with data (BUSY bit 1-to-0)
EP1-OUT	EP1-OUT has received USB data (BUSY bit 1-to-0)
EP2	IN: Buffer available (Empty Flag 1-to-0) OUT: Buffer has received USB data (Empty Flag 0-to-1)
EP4	IN: Buffer available (Empty Flag 1-to-0) OUT: Buffer has received USB data (Empty Flag 0-to-1)
EP6	IN: Buffer available (Empty Flag 1-to-0) OUT: Buffer has received USB data (Empty Flag 0-to-1)
EP8	IN: Buffer available (Empty Flag 1-to-0) OUT: Buffer has received USB data (Empty Flag 0-to-1)

#### 4.4.2.8 In-Bulk-NAK (IBN) Interrupt

When the host sends an IN token to any IN endpoint which does not have data to send, the FX2 automatically NAKs the IN token and asserts this interrupt.

#### 4.4.2.9 EPxPING Interrupt

These interrupts are active only during high speed (480 Mbits/sec) operation.

USB 2.0 improves the USB 1.1 bus bandwidth utilization by implementing a PING-NAK mechanism for OUT transfers. When the host wishes to send OUT data to an endpoint, it first sends a PING token to see if the endpoint is ready (i.e. if it has an empty buffer). If a buffer is not available, the FX2 returns a NAK handshake. PING-NAK transactions continue to occur until an OUT buffer is available, at which time the FX2 answers a PING with an ACK handshake and the host sends the OUT data to the endpoint.

The EPxPING interrupt is asserted when the host PINGs an endpoint and the FX2 responds with a NAK because no endpoint buffer memory is available.

#### 4.4.2.10 ERRLIMIT Interrupt

This interrupt is asserted when the USB error-limit counter has exceeded the preset error limit threshold. See Section 8.6.3.3 for full details.

#### 4.4.2.11 EPxISOERR Interrupt

These interrupts are asserted when an ISO data PID is missing or arrives out of sequence, or when an ISO packet is dropped because no buffer space is available (to receive an OUT packet) or no data is available to be sent (from an IN buffer).

### 4.5 USB-Interrupt Autovectors

The main USB interrupt is shared by 27 interrupt sources. To save the code and processing time which normally would be required to identify the individual USB interrupt source, the FX2 provides a second level of interrupt vectoring, called *Autovectoring*. When a USB interrupt is asserted, the FX2 pushes the program counter onto its stack then jumps to address 0x0043, where it expects to find a “jump” instruction to the USB Interrupt service routine.

The FX2 jump instruction is encoded as follows:

*Table 4-12. FX2 JUMP Instruction*

Address	Op-Code	Hex Value
0x0043	LJMP	0x02
0x0044	AddrH	0xHH
0x0045	AddrL	0xLL

If Autovectoring is enabled (AV2EN=1 in the INTSETUP register), the FX2 substitutes its INT2VEC byte (see Table 4-10) for the byte at address 0x0045. Therefore, if the high byte (“page”) of a jump-table address is preloaded at location 0x0044, the automatically-inserted INT2VEC byte at 0x0045 will direct the jump to the correct address out of the 27 addresses within the page.

As shown in Table 4-13, the jump table contains a series of jump instructions, one for each individual USB Interrupt source’s ISR.

Table 4-13. A Typical USB-Interrupt Jump Table

Table Offset	Instruction
0x00	LJMP SUDAV_ISR
0x04	LJMP SOF_ISR
0x08	LJMP SUTOK_ISR
0x0C	LJMP SUSPEND_ISR
0x10	LJMP USBRESET_ISR
0x14	LJMP HISPEED_ISR
0x18	LJMP EP0ACK_ISR
0x1C	LJMP SPARE_ISR
0x20	LJMP EP0IN_ISR
0x24	LJMP EP0OUT_ISR
0x28	LJMP EP1IN_ISR
0x2C	LJMP EP1OUT_ISR
0x30	LJMP EP2_ISR
0x34	LJMP EP4_ISR
0x38	LJMP EP6_ISR
0x3C	LJMP EP8_ISR
0x40	LJMP IBN_ISR
0x44	LJMP SPARE_ISR
0x48	LJMP EP0PING_ISR
0x4C	LJMP EP1PING_ISR
0x50	LJMP EP2PING_ISR
0x54	LJMP EP4PING_ISR
0x58	LJMP EP6PING_ISR
0x5C	LJMP EP8PING_ISR
0x60	LJMP ERRLIMIT_ISR
0x64	LJMP SPARE_ISR
0x68	LJMP SPARE_ISR
0x6C	LJMP SPARE_ISR
0x70	LJMP EP2ISOERR_ISR
0x74	LJMP EP2ISOERR_ISR
0x78	LJMP EP2ISOERR_ISR
0x7C	LJMP EP2ISOERR_ISR

## 4.5.1 USB Autovector Coding

To employ autovectoring for the USB interrupt:

1. Insert a jump instruction at 0x0043 to a table of jump instructions to the various USB interrupt service routines. Make sure the jump table starts on a 0x0100-byte page boundary.
2. Code the jump table with jump instructions to each individual USB interrupt service routine. This table has two important requirements, arising from the format of the INT2VEC Byte (zero-based, with the 2 LSBs set to 0):
  - It must begin on a page boundary (address 0xnn00)
  - The jump instructions must be four bytes apart.
3. The interrupt service routines can be placed anywhere in memory.
4. Write initialization code to enable the USB interrupt (INT2) and Autovectoring.

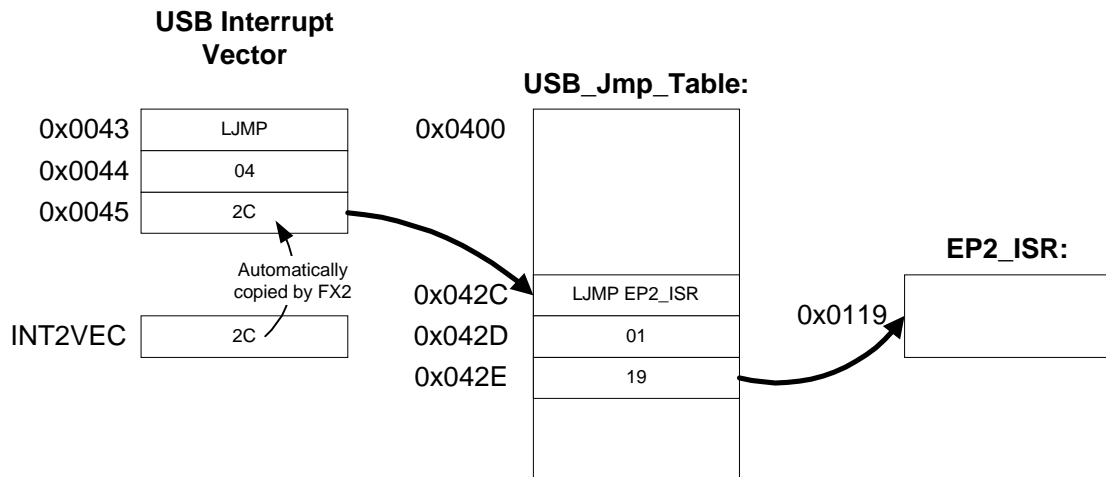

Figure 4-5. The USB Autovector Mechanism in Action

Figure 4-5 illustrates an ISR that services endpoint 2. When endpoint 2 requires service, the FX2 asserts the USB interrupt request, vectoring to location 0x0043.

The jump instruction at this location, which was originally coded as “LJMP 0400”, becomes “LJMP 042C” because the FX2 automatically inserts **2C**, the INT2VEC value for EP2 (Table 4-13).

The FX2 jumps to 0x042C, where it executes the jump instruction to the EP2 ISR, arbitrarily located for this example at address 0x0119.

Once the FX2 vectors to 0x0043, initiation of the endpoint-specific ISR takes only eight instruction cycles.

## 4.6 I<sup>2</sup>C-Compatible Bus Interrupt

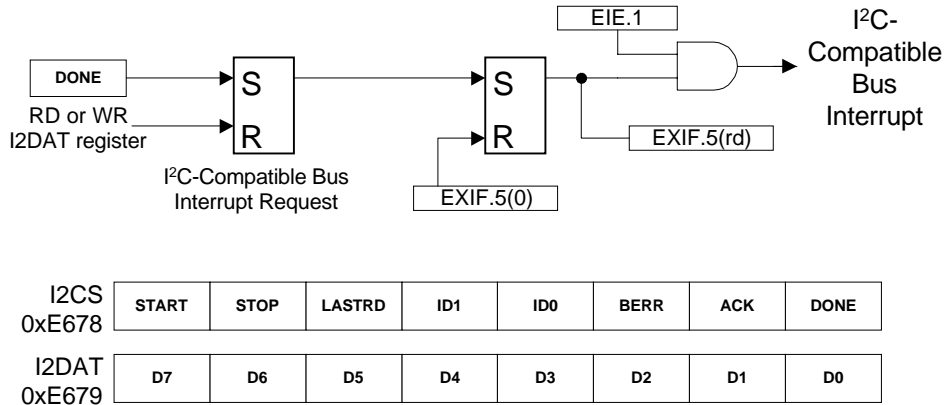

Figure 4-6. I<sup>2</sup>C-Compatible Bus Interrupt-Enable Bits and Registers

Chapter 13, "Input/Output" describes the interface to the FX2's I<sup>2</sup>C-Compatible Bus controller. The FX2 uses two registers, I2CS (Control and Status) and I2DAT (Data), to transfer data over the bus.

An I<sup>2</sup>C-Compatible Bus Interrupt is asserted whenever one of the following occurs:

- The DONE Bit (I2CS.0) makes a zero-to-one transition, signalling that the bus controller is ready for another command.
- The STOP bit (I2CS.6) makes a one-to-zero transition.

To enable the "Done" interrupt source, set EIE.1 to 1; to additionally enable the "Stop" interrupt source, set STOPIE to 1. If both interrupts are enabled, the interrupt source may be determined by checking the DONE and STOP Bits in the I2CS register.

To reset the Interrupt Request, write a zero to EXIF.5. Any firmware read or write to the I2DAT or I2CS register also automatically clears the Interrupt Request.



*While the I<sup>2</sup>C-Compatible Bus controller is generating the "stop" condition, it ignores accesses to the I2CS and I2DAT registers. Firmware should therefore check the STOP Bit for zero before writing new data to I2CS or I2DAT.*



## 4.7 FIFO/GPIF Interrupt (INT4)

Just as the USB Interrupt is shared among 27 individual USB-interrupt sources, the FIFO/GPIF interrupt is shared among 14 individual FIFO/GPIF sources.

The FIFO/GPIF Interrupt, like the USB Interrupt, can employ autovectoring. Table 4-14 shows the priority and INT4VEC values for the 14 FIFO/GPIF interrupt sources.

Table 4-14. Individual FIFO/GPIF Interrupt Sources

Priority	INT4VEC Value	Source	Notes
1	80	EP2PF	Endpoint 2 Programmable Flag
2	84	EP4PF	Endpoint 4 Programmable Flag
3	88	EP6PF	Endpoint 6 Programmable Flag
4	8C	EP8PF	Endpoint 8 Programmable Flag
5	90	EP2EF	Endpoint 2 Empty Flag
6	94	EP4EF	Endpoint 4 Empty Flag
7	98	EP6EF	Endpoint 6 Empty Flag
8	9C	EP8EF	Endpoint 8 Empty Flag
9	A0	EP2FF	Endpoint 2 Full Flag
10	A4	EP4FF	Endpoint 4 Full Flag
11	A8	EP6FF	Endpoint 6 Full Flag
12	AC	EP8FF	Endpoint 8 Full Flag
13	B0	GPIFDONE	GPIF Operation Complete (See Chapter 10, "General Programmable Interface (GPIF)")
14	B4	GPIFWF	GPIF Waveform (See Chapter 10, "General Programmable Interface (GPIF)")

When FIFO/GPIF interrupt sources are asserted, the FX2 prioritizes them and constructs an Autovector, which appears in the INT4VEC register; 0 is the highest priority, 14 is the lowest. If two FIFO/GPIF interrupts occur simultaneously, the prioritization affects which one is first indicated in the INT4VEC register. If Autovectoring is enabled, the INT4VEC byte replaces the contents of address 0x0055 in the FX2's program memory. This causes the FX2 to automatically vector to a different address for each FIFO/GPIF interrupt source. This mechanism is explained in detail in Section 4.8 "FIFO/GPIF-Interrupt Autovectors".

**Important**

It is important in any FIFO/GPIF Interrupt Service Routine (ISR) to clear the main INT4 Interrupt **before** clearing the individual FIFO/GPIF interrupt request latch. This is because as soon as the individual FIFO/GPIF interrupt is cleared, any pending FIFO/GPIF interrupt will immediately try to generate another main FIFO/GPIF Interrupt. If the main INT4 IRQ bit has not been previously cleared, the pending interrupt will be lost.

The registers associated with the individual FIFO/GPIF interrupt sources are described in *Chapter 15, "Registers"* and Section 8.6, "CPU Control of FX2 Endpoints". Each interrupt source has an enable (IE) and a request (IRQ) bit. Firmware sets the IE bit to 1 to enable the interrupt. The FX2 sets an IRQ bit to 1 to request an interrupt, and the firmware clears an IRQ bit by setting it to 1.



The main FIFO/GPIF interrupt request is cleared by **clearing** the EXIF.6 bit to 0; each individual FIFO/GPIF interrupt is cleared by **setting** its IRQ bit to 1.

---

## 4.8 FIFO/GPIF-Interrupt Autovectors

---

The main FIFO/GPIF interrupt is shared by 14 interrupt sources. To save the code and processing time which normally would be required to sort out the individual FIFO/GPIF interrupt source, the FX2 provides a second level of interrupt vectoring, called *Autovectoring*. When a FIFO/GPIF interrupt is asserted, the FX2 pushes the program counter onto its stack then jumps to address 0x0053, where it expects to find a "jump" instruction to the FIFO/GPIF Interrupt service routine.

The FX2 jump instruction is encoded as follows:

Table 4-15. FX2 JUMP Instruction

Address	Op-Code	Hex Value
0x0053	LJMP	0x02
0x0054	AddrH	0xHH
0x0055	AddrL	0xLL

If Autovectoring is enabled (AV4EN=1 in the INTSETUP register), the FX2 substitutes its INT4VEC byte (see Table 4-14) for the byte at address 0x0055. Therefore, if the high byte ("page") of a jump-table address is preloaded at location 0x0054, the automatically-inserted INT4VEC byte at 0x0055 will direct the jump to the correct address out of the 14 addresses within the page.

As shown in Table 4-16, the jump table contains a series of jump instructions, one for each individual FIFO/GPIF Interrupt source's ISR.

*Table 4-16. A Typical FIFO/GPIF-Interrupt Jump Table*

Table Offset	Instruction
0x80	LJMP EP2PF_ISR
0x84	LJMP EP4PF_ISR
0x88	LJMP EP6PF_ISR
0x8C	LJMP EP8PF_ISR
0x90	LJMP EP2EF_ISR
0x94	LJMP EP4EF_ISR
0x98	LJMP EP6EF_ISR
0x9C	LJMP EP8EF_ISR
0xA0	LJMP EP2FF_ISR
0xA4	LJMP EP4FF_ISR
0xA8	LJMP EP6FF_ISR
0xAC	LJMP EP8FF_ISR
0xB0	LJMP GPIFDONE_ISR
0xB4	LJMP GPIFWF_ISR

### **4.8.1 FIFO/GPIF Autovector Coding**

To employ autovectoring for the FIFO/GPIF interrupt, perform the following steps:

1. Insert a jump instruction at 0x0053 to a table of jump instructions to the various FIFO/GPIF interrupt service routines. Make sure the jump table starts at a 0x0100-byte page boundary *plus 0x80*.
2. Code the jump table with jump instructions to each individual FIFO/GPIF interrupt service routine. This table has two important requirements, arising from the format of the INT4VEC byte (0x80-based, with the 2 LSBs set to 0); the two requirements are the following:
  - It must begin on a page boundary + 0x80 (address 0xnn80).
  - The jump instructions must be four bytes apart.
3. Place the interrupt service routines anywhere in memory.
4. Write initialization code to enable the FIFO/GPIF interrupt (INT4) and Autovectoring.

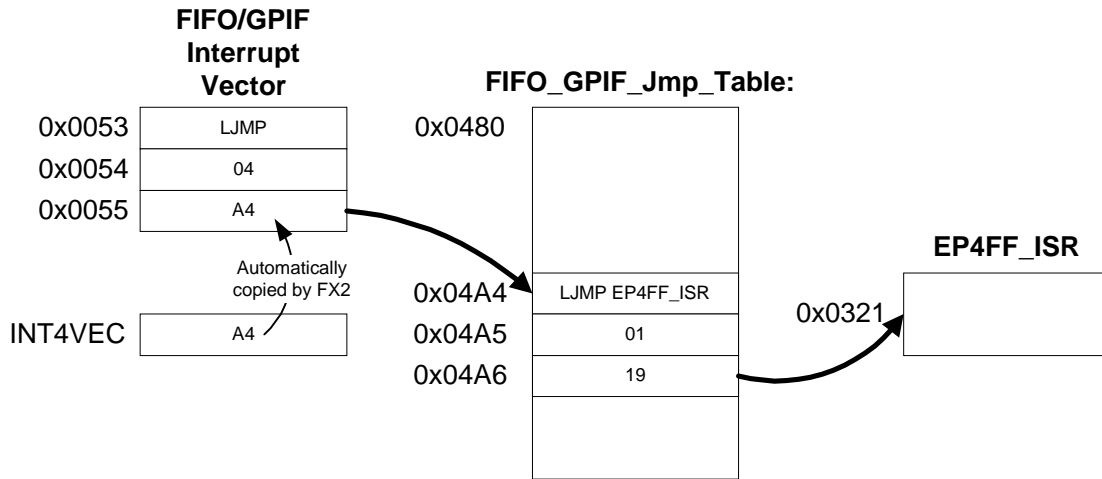

Figure 4-7. The FIFO/GPIF Autovector Mechanism in Action

Figure 4-7 illustrates an ISR that services EP4's Full Flag. When EP4 goes full, the FX2 asserts the FIFO/GPIF interrupt request, vectoring to location 0x0053.

The jump instruction at this location, which was originally coded as "LJMP 0480", becomes "LJMP 04A4" because the FX2 automatically inserts **A4**, the INT4VEC value for EP4FF (Table 4-13).

The FX2 jumps to 0x04A4, where it executes the jump instruction to the EP4FF ISR, arbitrarily located for this example at address 0x0321.

Once the FX2 vectors to 0x0053, initiation of the endpoint-specific ISR takes only eight instruction cycles.

## Chapter 5 Memory

### 5.1 Introduction

Memory organization in the FX2 is similar, but not identical, to that of the standard 8051. There are three distinct memory areas: Internal Data Memory, External Data Memory, and External Program Memory. As will be explained below, “External” memory is **not** necessarily external to the FX2 chip.

### 5.2 Internal Data RAM

As shown in Figur e5-1, the FX2’s Internal Data RAM is divided into three distinct regions: the “Lower 128”, the “Upper 128”, and “SFR Space”. The Lower 128 and Upper 128 are general-purpose RAM; the SFR Space contains FX2 control and status registers.

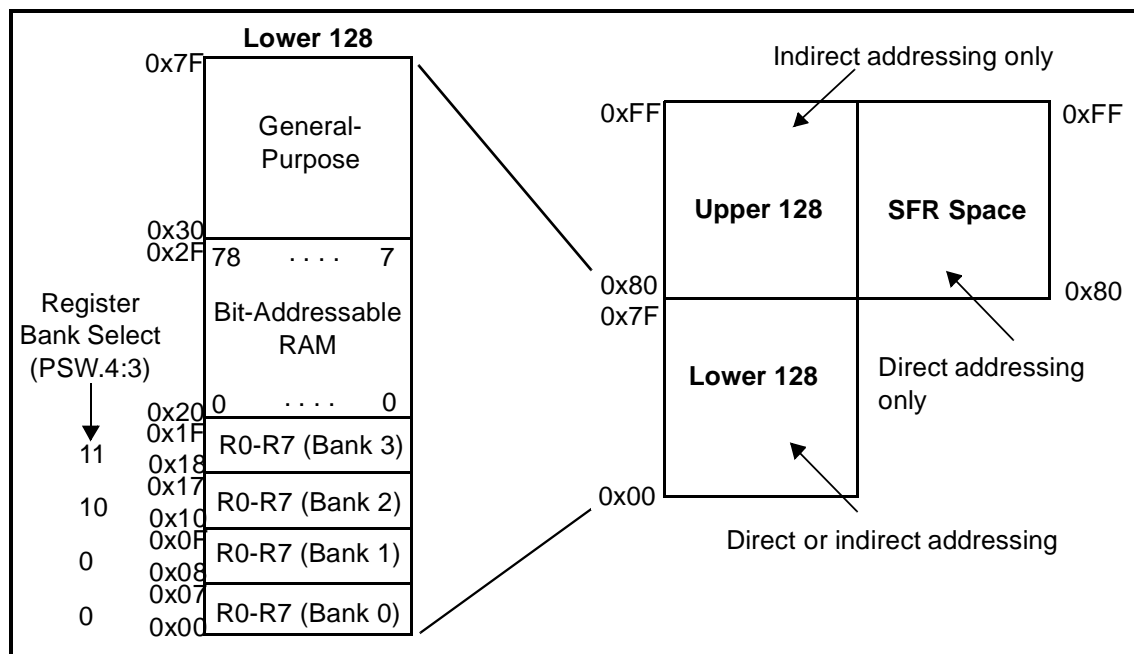

Figure 5-1. Internal Data RAM Organization

---

### 5.2.1 The Lower 128

The Lower 128 occupies Internal Data RAM locations 0x00-0x7F. All of the Lower 128 may be accessed as general-purpose RAM, using either *direct* or *indirect* addressing (for more information on the FX2 addressing modes, see *Chapter 12 "Instruction Set"*).

Two segments of the Lower 128 may additionally be accessed in other ways.

- Locations 0x00-0x1F comprise four banks of 8 registers each, numbered R0 through R7. The current bank is selected via the "register-select" bits (RS1:RS0) in the PSW special-function register; code which references registers R0-R7 will access them only in the currently-selected bank.
- Locations 0x20-0x2F are bit-addressable. Each of the 128 bits in this segment may be individually addressed, either by its bit address (0x00 to 0x7F) or by reference to the byte which contains it (0x20.0 to 0x2F.7).

---

### 5.2.2 The Upper 128

The Upper 128 occupies Internal Data RAM locations 0x80-0xFF; all 128 bytes may be accessed as general-purpose RAM, but only by using *indirect* addressing (for more information on the FX2 addressing modes, see *Chapter 12 "Instruction Set"*).

Since the FX2's stack is internally accessed using indirect addressing, it's a good idea to put the stack in the Upper 128; this frees the more-efficiently-accessed Lower 128 for General-Purpose use.

---

### 5.2.3 SFR (Special Function Register) Space

The SFR Space, like the Upper 128, is accessed at Internal Data RAM locations 0x80-0xFF. The FX2 keeps SFR Space separate from the Upper 128 by using different addressing modes to access the two regions: SFRs may only be accessed using *direct* addressing, and the Upper 128 may only be accessed using *indirect* addressing.

The SFR Space contains FX2 control and status registers; an overview is in Section 11.12, "Special Function Registers (SFR)", and a full description of all the SFRs is in *Chapter 15 "Registers"*.

The sixteen SFRs at locations 0x80, 0x88, ..., 0xF0, 0xF8 are bit-addressable. Each of the 128 bits in these registers may be individually addressed, either by its bit address (0x80 to 0xFF) or by reference to the byte which contains it (e.g., 0x80.0, 0xC8.7, etc.).

---

## 5.3 External Program Memory and External Data Memory

---

The standard 8051 employs a Harvard architecture for its External memory; the program and data memories are physically separate. The FX2 uses a modified version of this memory model; *off-chip* program and data memories are separate, but the *on-chip* program and data memories are unified in a Von Neumann architecture. This allows the FX2's on-chip RAM to be loaded from an external source (USB or EEPROM, see *Chapter 3 "Enumeration and ReNumeration™"*), then used as program memory.

### **Standard 8051**

The standard 8051 has separate address spaces for program and data memory; it can address 64K of read-only program memory at addresses 0x0000-0xFFFF, and another 64K of read/write data memory, *also* at addresses 0x0000-0xFFFF. The standard 8051 keeps the two memory spaces separate by using different bus signals to access them; the read strobe for program memory is PSEN (Program Store Enable), and the read and write strobes for data memory are RD and WR. The 8051 generates PSEN strobes for instruction fetches and for the MOVC (move code memory into the accumulator) instruction; it generates RD and WR strobes for all data-memory accesses. In a standard 8051 application, an external 64K ROM chip (enabled by the 8051's PSEN signal) might be used for program memory and an external 64K RAM chip (enabled by the 8051's RD and WR signals) might be used for data memory.

*In the standard 8051, all program memory is read-only.*

### **FX2**

The FX2 has 8K of on-chip RAM (the "Main RAM") at addresses 0x0000-0x1FFF, and 512 bytes of on-chip RAM (the "Scratch RAM") at addresses 0xE000-0xE1FFF. Although this RAM is physically located inside the chip, it's addressed by FX2 firmware as *External* memory, just as though it were in an external RAM chip.

Some systems use only this on-chip RAM, with no off-chip memory. In those systems, the RD and PSEN strobes are automatically combined for accesses to addresses below 0x2000, so the Main RAM is accessible as *both* data and program memory. The RD and PSEN strobes are *not* combined for the Scratch RAM; Scratch RAM is accessible as data memory only.

Although it's technically accurate to say that the Main RAM *data* memory is writable while the Main RAM *program* memory is not, it's a distinction without a difference. The Main RAM is accessible both as program memory and data memory, so writing to Main RAM data memory is equivalent to writing to Main RAM program memory at the same address.

The Scratch RAM is never accessible as program memory.

The FX2 also reserves 7.5K (0xE200-0xFFFF) of the data-memory address space for control/status registers and endpoint buffers (see *Section 5.6, "On-Chip Data Memory at 0xE000-0xFFFF"*).

Note that *only* the data-memory space is reserved; *program* memory in the 0xE000-0xFFFF range is not reserved, so the 128-pin FX2 can access off-chip program memory in that range.

---

### 5.3.1 56- and 100-pin FX2

The 56- and 100-pin FX2 chips have no facility for adding off-chip program or data memory. Therefore, the Main RAM must serve as both program and data memory. To accomplish this, the FX2 reads the Main RAM using the logical OR of the PSEN and RD strobes. It is the responsibility of the system designer to ensure that the program- and data-memory spaces do not overlap; with most C compilers, this is done by using linker directives that place the code and data modules into separate areas.

---

### 5.3.2 128-pin FX2

It is possible to add off-chip program and data memory to the 128-pin FX2; the organization of that memory depends on the state of the EA (External Access) pin.

#### **EA = 0**

*The Main RAM is accessible both as program and data memory, just as in the 56- and 100-pin FX2.*

To avoid conflict with the Main RAM, the pins which control access to off-chip memory (the  $\overline{RD}$ ,  $\overline{WR}$ ,  $\overline{CS}$ ,  $\overline{OE}$ , and  $\overline{PSEN}$  pins) are inactive whenever the FX2 accesses addresses 0x0000-0x1FFF. This allows a 64K memory chip (data and/or program) to be added without requiring additional external logic to inhibit access to the lower 8K of that chip. Note that the PSEN and RD signals are available on separate pins, so the program and data spaces *outside* the FX2 are not combined as they are *inside* the FX2.

When code in the range 0x0000-0x1FFF is fetched from the on-chip RAM, the  $\overline{PSEN}$  pin is *not* asserted; when code is fetched from program memory in the range 0x2000-0xFFFF, the  $\overline{PSEN}$  pin is asserted.

#### **EA = 1**

*All program memory is off-chip; all on-chip RAM, including the Main RAM, is data memory only.*

The FX2 reads all on-chip RAM using only the RD strobe; the combining of RD and PSEN is disabled, so the on-chip RAM becomes data memory only. All program memory is off-chip; accesses to the lower 8K of off-chip program memory are not inhibited.

Any code fetch will assert the  $\overline{PSEN}$  pin.

After a power-on-reset, the FX2 immediately begins executing code at address 0x0000 in the off-chip program memory, rather than waiting for an EEPROM load or USB code download to complete (see *Chapter 7 "Resets"* for a full description of the FX2 resets).



## 5.4 FX2 Memory Maps

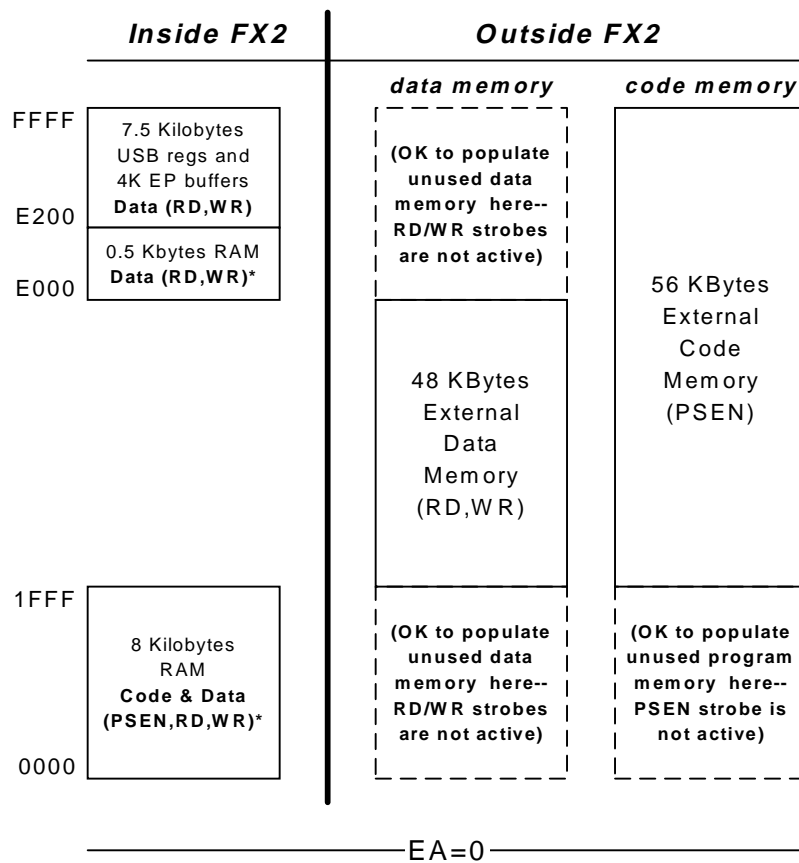

\* SUDPTR, USB upload/download, EEPROM boot access

Figure 5-2. FX2 External Program/Data Memory Map, EA=0

Figure 5-2 illustrates the memory map of the 128-pin FX2 with off-chip program and data memory.



The 56- and 100-pin FX2 chips cannot access off-chip memory; the entire memory map for those chips is illustrated on the left side of Figure 5-2, in the "Inside FX2" column.

On-chip FX2 memory consists of three RAM regions:

- 0x0000-0x1FFF (Main RAM)
- 0xE000-0xE1FF (Scratch RAM)
- 0xE200-0xFFFF (Registers/Buffers)

The 8K “Main RAM” occupies code-memory (PSEN) and data-memory (RD/WR) addresses 0x0000-0x1FFF.

The 512-byte “Scratch RAM” occupies data-memory (RD/WR) addresses 0xE000-0xE1FF.

7.5K of control/status registers and endpoint buffers occupy data-memory (RD/WR) addresses 0xE200-0xFFFF.

*When off-chip memory is connected to the FX2, it fills in the gaps not occupied by on-chip FX2 RAM. Since the lower 8K of memory is occupied by on-chip program/data memory and the upper 8K is occupied by on-chip data memory, the off-chip memory cannot be active in these regions. Nevertheless, it's still safe to *populate* those regions with off-chip memory, as the following paragraphs explain.*

The middle column of Figure 5-2 indicates FX2 data memory (activated by the RD and WR strobes) and the right-most column indicates FX2 code memory (activated by PSEN).

The “middle” 48K of the data-memory space may be filled with off-chip memory, since it does not conflict with the upper and lower 8K of on-chip FX2 data memory. To allow a 64K RAM to be connected to the FX2, the FX2 gates its RD and WR strobes to exclude the top and bottom 8K for off-chip accesses. Therefore, a 64K RAM can be connected to FX2, and the top and bottom 8K of it are automatically disabled.

Likewise, when a 64K *code* memory (PSEN strobe) is attached to the FX2 (when EA = 0), the lower 8K is automatically excluded for off-chip code fetches, avoiding conflict with the on-chip code memory inside FX2.



*The asterisks in Figures 5-2 and 5-3 indicate memory regions that may be accessed using three special FX2 resources:*

- Setup Data Pointer (see Section 8.7)
- Upload or download via USB (see Section 3.8)
- Code boot from an I<sup>2</sup>C-compatible EEPROM (see Section 13.5 and Section 3.4)

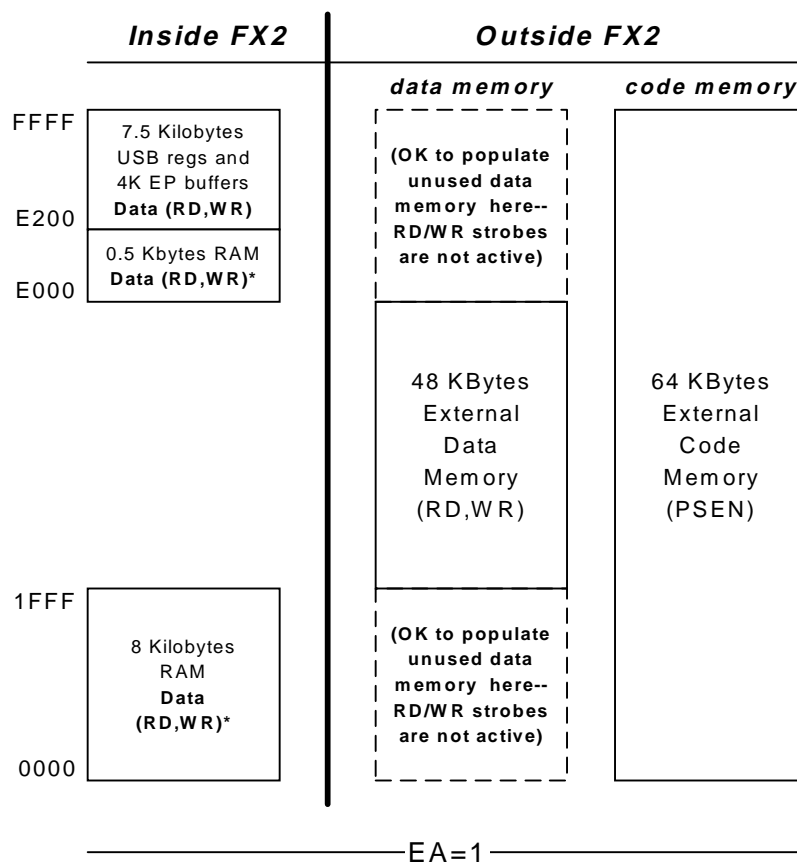

\* SUDPTR, USB upload/download, EEPROM boot access

Figure 5-3. FX2 External Program/Data Memory Map, EA=1

Figure 5-3 illustrates the 128-pin FX2 memory map when the EA pin is tied high. *The only difference from Figure 5-2 is that the Main RAM is data memory only, instead of combined code/data memory.* This allows an off-chip code memory to contain all of the FX2 firmware. In this configuration, the FX2 can begin executing code from off-chip memory immediately after power-on-reset.



*FX2 code execution begins at address 0x0000, where the reset vector is located.*

Off-chip *data* memory is partially disabled just as in Figure 5-2, ensuring that off-chip data memory does not conflict with on-chip data RAM.



Be careful to check the access time of external Flash or other code memory in this mode. The FX2 can stretch its RD and WR strobes to compensate for slow **data** memories, but it does not have the capability to stretch its PSEN signal to allow for slow **code** memories. At 48 MHz, an external code-memory chip must have an access time of approximately 44 ns or shorter (access-time parameters are given in the CY7C68013 data sheet).

---

## 5.5 “Von-Neumannizing” Off-Chip Program and Data Memory

---

The 128-pin FX2 package provides a 16-bit address bus, an 8-bit data bus, and memory control signals PSEN, RD, and WR. These signals are used to expand the FX2’s External Program and/or External Data memory.

As described in the previous section, the FX2 gates the  $\overline{RD}$  and  $\overline{WR}$  signals to exclude selection of off-chip data memory in the range occupied by the on-chip memory. The  $\overline{PSEN}$  signal is also available on a pin for connection to off-chip code memory.

In some systems, it may be desirable to combine off-chip program and data memory, just as the FX2 combines its on-chip program/data Main RAM. These systems must logically OR the PSEN and RD strobes to qualify the off-chip memory’s chip enable and output enable signals. To save the external logic which would normally be needed, FX2 provides two additional control signals,  $\overline{CS}$  and  $\overline{OE}$ . The equations for these active-low signals are:

$$\overline{CS} = \overline{RD + WR + PSEN}$$

$$\overline{OE} = \overline{RD + PSEN}$$

Because the RD, WR, and PSEN signals are already qualified by the addresses allocated to off-chip memory, the added strobes  $\overline{CS}$  and  $\overline{OE}$  strobes are active only when the FX2 accesses off-chip memory.

## 5.6 On-Chip Data Memory at 0xE000-0xFFFF

FFFF FC00	EP8 Buffer (1024)
FBFF F800	EP6 Buffer (1024)
F7FF F400	EP4 Buffer (1024)
F3FF F000	EP2 Buffer (1024)
EFFF	RESERVED (2048)
E800	
E7FF E7C0	EP1IN (64)
E7BF E780	EP1OUT (64)
E77F E740	EP0 IN/OUT (64)
E73F E700	UNAVAILABLE (64)
E6FF E600	Registers (256)
E5FF E480	RESERVED (384)
E47F E400	GPIF waveforms (128)
E3FF	RESERVED (512)
E200	
E1FF	8051 data (512)
E000	

Figure 5-4. On-Chip Data Memory at 0xE000-0xFFFF

Figure 5-4 shows the memory map for on-chip data RAM at 0xE000-0xFFFF.

512 bytes of Scratch RAM is available at 0xE000-0xE1FF. This is data RAM only; code cannot be run from it. The 128 bytes at 0xE400-0xE47F hold the four waveform descriptors for the GPIF, described in Chapter 10. The shaded area from 0xE600-0xE6FF contains FX2 control and status registers.

Memory blocks 0xE200-0xE3FF, 0xE480-0xE5FF, 0xE700-0xE73F, and 0xE800-0xEFFF) are reserved; they must not be used for data storage.

The remaining RAM contains the endpoint buffers. These buffers are accessible either as addressable data RAM (via the 'MOVX' instruction) or as a FIFO (via the Autopointer, described in Section 8.8).



## Chapter 6 Power Management

---

### 6.1 Introduction

---

The USB host can *suspend* a device to put it into a power-down mode. When the USB signals a SUSPEND operation, the FX2 goes through a sequence of steps to allow the firmware first to turn off external power-consuming subsystems, and then to enter a low-power mode by turning off the FX2's oscillator. Once suspended, the FX2 is awakened either by resumption of USB bus activity or by assertion of one of its two WAKEUP pins (provided that they're enabled). This chapter describes the suspend-resume mechanism.

It is important to understand the distinction between 'suspend', 'resume', 'idle', and 'wakeUp'.

- **SUSPEND** is a request—indicated by a 3-millisecond “J” state on the USB bus—from the USB host/hub to the device. This request is usually sent by the host when *it* enters a low-power “suspended” state. USB devices are required to enter a low power state in response to this request.

The FX2 also provides a register called SUSPEND; writing any value to it will allow the FX2 to enter the suspended state even when a SUSPEND condition doesn't exist on the bus.

- **RESUME** is a signal from the device to the host, requesting that the host be taken out of its low-power “suspended” mode. RESUME can be signaled only by a USB device that has reported (via its Configuration Descriptor) that it supports this “remote wakeup” feature, and only if the host has enabled remote wakeup from that device.
- **Idle** is an FX2 low-power state. FX2 firmware initiates this mode by setting bit 0 of the PCON (Power Control) register. To meet the stringent USB suspend current specification, the FX2's oscillator must be stopped; after the PCON.0 bit is set, the oscillator will stop if a) a SUSPEND condition exists on the bus or the SUSPEND register has been written to, and b) the two WAKEUP pins are either disabled or false. The FX2 exits the **Idle** state when it receives a Wakeup Interrupt.
- **WakeUp** is the mechanism which restarts the FX2 oscillator and asserts an interrupt to force the FX2 to exit the Idle state and resume code execution. The FX2 recognizes three wakeup sources: one from the USB itself (when bus activity resumes) and two from device pins (WAKEUP and WU2).

The FX2 enters and exits its **Idle** state independent of USB activity; in other words, the FX2 can enter the **Idle** state at any time, even when not connected to USB. The **Idle** state is “hooked into” the USB SUSPEND-RESUME mechanism using interrupts. An interrupt is automatically generated when the USB goes inactive for 3 milliseconds; FX2 firmware may respond to that interrupt by entering the **Idle** state to reduce power. If the FX2 is in the **Idle** state, a Wakeup Interrupt is generated when one of the three Wakeup sources is asserted; the FX2 responds to that interrupt by exiting the **Idle** state and resuming code execution.

Once the FX2 is awake, its firmware may send a USB RESUME request by setting the SIGRSUME bit in the USBCS register (at 0xE680). Before sending the RESUME request, the device must have: a) reported remote-wakeup capability in its Configuration Descriptor, and b) been given permission (via a *Set Feature-Remote Wakeup* request from the host) to use that remote-wakeup capability. To be compliant with the USB Specification, firmware should wait 5 milliseconds after the wakeup interrupt, set the SIGRSUME bit, wait 10-15 milliseconds, then clear it.

Figure 6-1 illustrates the FX2 logic that implements USB suspend and resume. These operations are explained in the next sections.

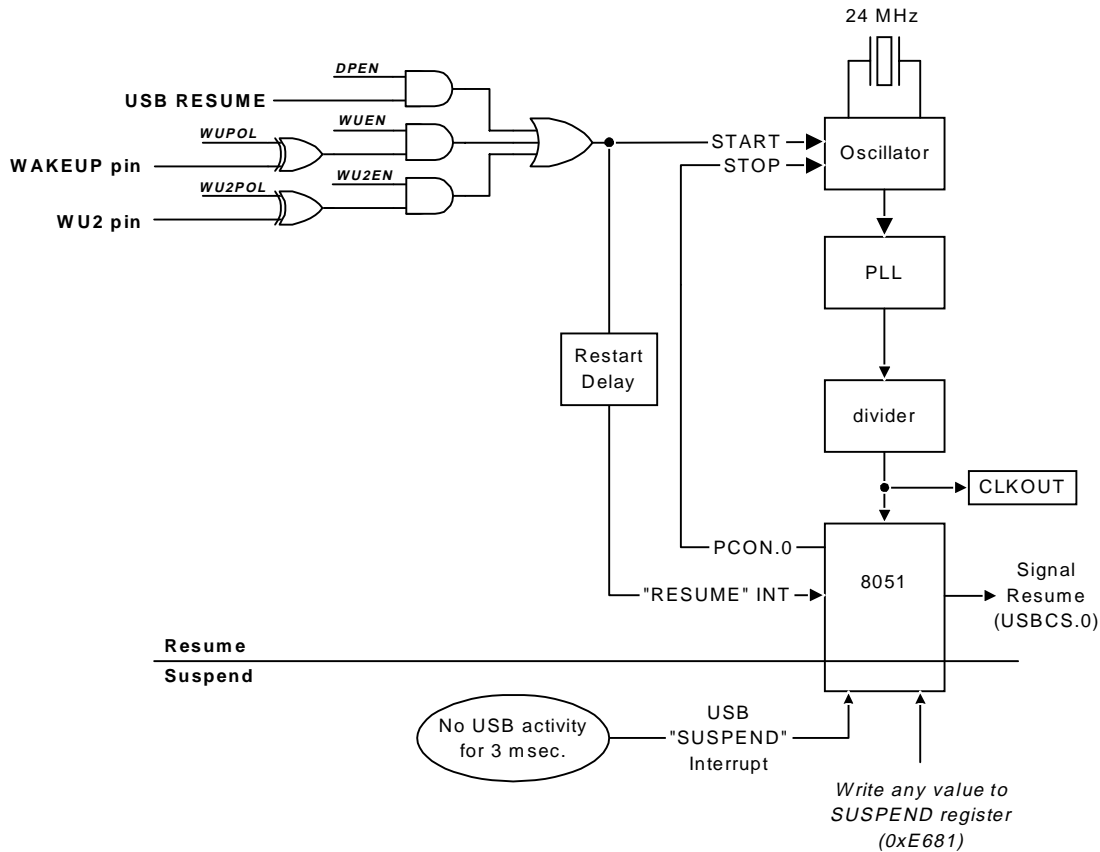

Figure 6-1. Suspend-Resume Control



## 6.2 USB Suspend

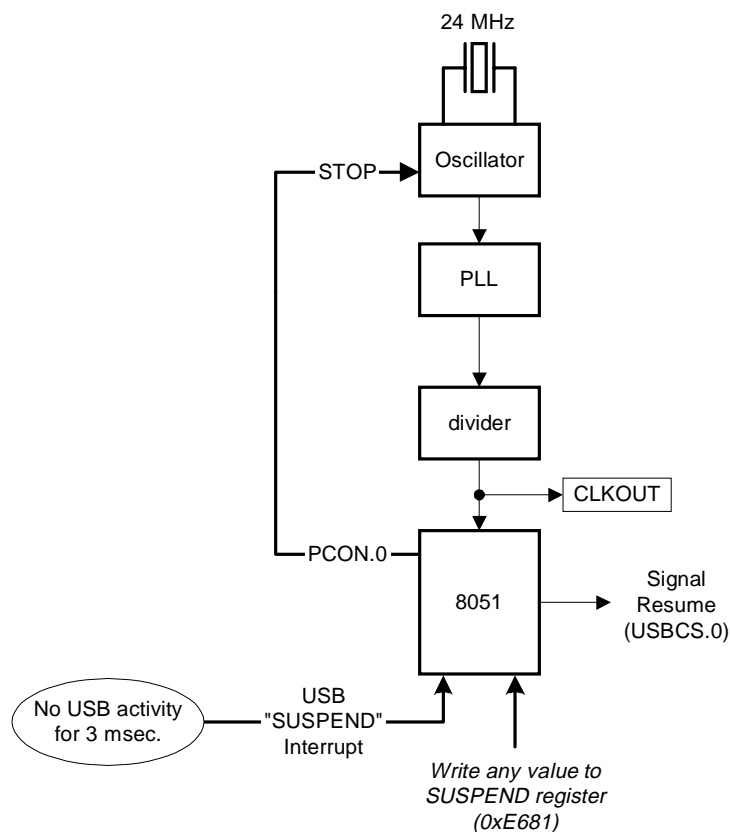

Figure 6-2. USB Suspend sequence

A USB device recognizes a SUSPEND request as three milliseconds of the bus-idle (“J”) state. When the FX2 detects this condition, it asserts the USB interrupt (INT2) and the SUSPEND interrupt autovector (vector #3).

If the CPU is in reset when a SUSPEND condition is detected on the bus, the FX2 will automatically turn off its oscillators (and keep the CPU in reset) until an enabled wakeup source is asserted.



The bus-idle (“J”) state is **not** equivalent to the disconnected-from-USB state; the “J” state means that the voltage on D+ is higher than that on D-.

FX2 firmware responds to the SUSPEND interrupt by taking the following actions:

1. Perform any necessary housekeeping such as shutting off external power-consuming devices.
2. Set bit 0 of the PCON register.

These actions put the FX2 into a low power ‘suspend’ state, as required by the USB Specification.

---

### 6.2.1 SUSPEND Register

FX2 firmware can force the chip into its low-power mode at any time, even without detecting a 3-millisecond “J” state on the USB bus. This “unconditional suspend” functionality is useful in applications which require the FX2 to enter its low-power mode even while disconnected from the USB bus.

To force the FX2 unconditionally to enter its low-power mode, firmware simply writes any value to the SUSPEND register (at 0xE681) before setting the PCON.0 bit.

---

## 6.3 Wakeup/Resume

---

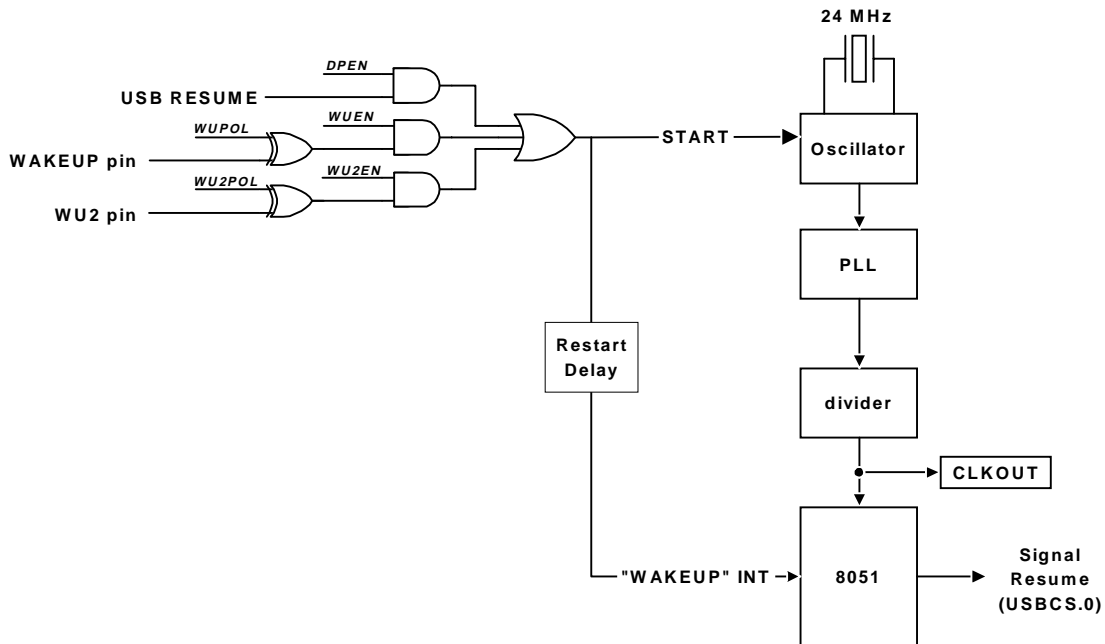

Figure 6-3. FX2 Wakeup/Resume sequence

Once in the low-power mode, there are three ways to wake up the FX2:

- USB activity on the FX2's DPLUS pin
- Assertion of the WAKEUP pin
- Assertion of the WU2 ("Wakeup 2") pin

These three wakeup sources may be individually enabled by setting the DPEN, WUEN, and WU2EN bits in the Wakeup Control register.

**WAKEUPCS** **Wakeup Control & Status** **E682**

b7	b6	b5	b4	b3	b2	b1	b0
<b>WU2</b>	<b>WU</b>	<b>WU2POL</b>	<b>WUPOL</b>	<b>0</b>	<b>DPEN</b>	<b>WU2EN</b>	<b>WUEN</b>
R/W	R/W	R/W	R/W	R	R/W	R/W	R/W
0	0	0	0	0	1	0	1

The polarities of the wakeup pins are set using the WUPOL and WU2POL bits; 0 is active low and 1 is active high.

Three bits in the WAKEUP register enable the three wakeup sources. DPEN stands for "DPLUS Enable" (DPLUS is one of the USB data lines; the other is DMINUS).

WUEN (Wakeup Enable) enables the WAKEUP pin, and WU2EN (Wakeup 2 Enable) enables the WU2 pin.

When the FX2 chip detects activity on DPLUS while DPEN is true, or a false-to-true transition on WAKEUP or WU2 while WUEN or WU2EN is true, it asserts the "wakeup" interrupt.

The status bits WU and WU2 indicate which of the wakeup pins caused the wakeup event. Asserting the wakeup pin (according to its programmed polarity) sets the corresponding bit. If the wakeup was caused by resumption of USB DPLUS activity, neither of these bits is set, leading to the conclusion that the third source, a USB bus reset, caused the wakeup event. FX2 firmware clears the WU and WU2 flags by writing "1" to them.

### **6.3.1 Wakeup Interrupt**

When a wakeup event occurs, the FX2 restarts its oscillator and, after the PLL stabilizes, it generates an interrupt request. This applies whether or not the FX2 is connected to the USB. The Wakeup Interrupt is a dedicated interrupt, and is not shared by USBINT like most of the other individual USB interrupts.

The Wakeup Interrupt vector is at 0x33, and has the highest interrupt priority. It is enabled by EICON.5, and its IRQ flag is at EICON.4 (EICON is SFR 0xD8).

The Wakeup Interrupt Service Routine clears the interrupt request flag (using the 'bit clear' instruction, i.e. 'clr EICON.4'), and then executes a 'reti' (return from interrupt) instruction. This causes the FX2 to continue program execution at the instruction following the one that set PCON.0 to initiate the power-down operation.

### **About the Wakeup Interrupt**

The FX2 enters its idle state when it sets PCON.0 to 1. Although a standard 8051 exits the idle state when *any* interrupt occurs, the FX2 supports only the Wakeup Interrupt to exit the idle state.



*If PCON.0 is set when no Suspend condition exists (i.e., the USB is not signaling "Suspend", and firmware hasn't written to the SUSPEND register), the Wakeup Interrupt will fire immediately.*

## **6.4 USB Resume (Remote Wakeup)**

USBCS		USB Control and Status						7FD6
b7	b6	b5	b4	b3	b2	b1	b0	
HSM	-	-	-	DISCON	NOSYNSOF	RENUM	SIGRSUME	

Figure 6-4. USB Control and Status register

Firmware sets the SIGRSUME bit to send a remote-wakeup request to the host. To be compliant with the USB Specification, the firmware should wait 5 milliseconds after the wakeup interrupt, set the SIGRSUME bit, wait 10-15 milliseconds, then clear it.



*Holding either WAKEUP pin in its active state (as determined by the programmed polarity) inhibits the FX2 chip from turning off its oscillator in order to enter the 'suspend' state.*

The Default USB Device does not support remote wakeup. This fact is reported at enumeration time in byte 7 of the built-in Configuration Descriptor (see Appendices A and B).

### **6.4.1 WU2 Pin**

The WU2 function shares the general-purpose I/O pin PA3. Unlike other multi-purpose I/O pins that use configuration registers (PORTACFG, PORTBCFG and PORTCCFG) to select alternate

functions, the PA3 and WU2 functions are *simultaneously* active. However, the WU2 function has no effect unless enabled (by setting the WU2EN bit to 1). If WU2 is used as a wakeup pin, make sure to set PA3 as an input (OEA.3=0, the default state) to prevent PA3 from also driving the pin.

The dual nature of the PA3/WU2 pin allows the FX2 to enter the low-power mode, then periodically awaken itself. This is done by connecting an RC network to the PA3/WU2 pin; if the WU2 pin is set to the default polarity (active-high), the resistor is connected to 3.3V and the capacitor is connected to ground.

The firmware then performs the following steps:

1. Set W2POL to 1 for active-high polarity on the WU2 pin.
2. Set WU2EN to 1 to enable Wakeup 2.
3. Enable the wakeup interrupt by setting EICON.5=1.
4. Set PA3 to 0, then set OEA.3 to 1. This enables the PA3 output and drives the PA3/WU2 pin to ground, discharging the capacitor.
5. Set OEA.3 to 0. This floats the PA3/WU2 pin, allowing the resistor to begin charging the capacitor.
6. Write any value to the SUSPEND register, so the FX2 will unconditionally stop the oscillator when the firmware sets PCON.0.
7. Set PCON.0 to 1. This commands the FX2 to enter the **Idle** state.

After the capacitor charges to a logic high level, the wakeup interrupt triggers via the WU2 pin.

8. In the Wakeup interrupt service routine, clear EICON.4 (the wakeup interrupt request flag), then execute a 'reti' instruction. This resumes program execution at the instruction following the instruction in step 7.
9. At this point, the firmware can check for any tasks to perform; if none are required, it can then re-enter the **Idle** state starting at step 4.

By selecting a long time constant for the RC network attached to the WU2 pin, the FX2 chip can operate at extremely low average power, since the on/off (active/suspend) duty-cycle is very short.



## Chapter 7 Resets

### 7.1 Introduction

The FX2 chip has two internal resets:

- *Power-On Reset (POR)*, controlled by the  $\overline{\text{RESET}}$  pin, which puts the FX2 in a known state.
- *CPU Reset*, controlled by the FX2's USB Core logic. The CPU Reset is always asserted (i.e., the CPU is always held in reset) while the FX2's  $\overline{\text{RESET}}$  pin is asserted.

Additionally, the USB Specification defines a *USB Bus Reset*, which is a condition on the bus initiated by the USB host in order to put every device's USB functions in a known state.

This chapter describes the effects of these three resets.

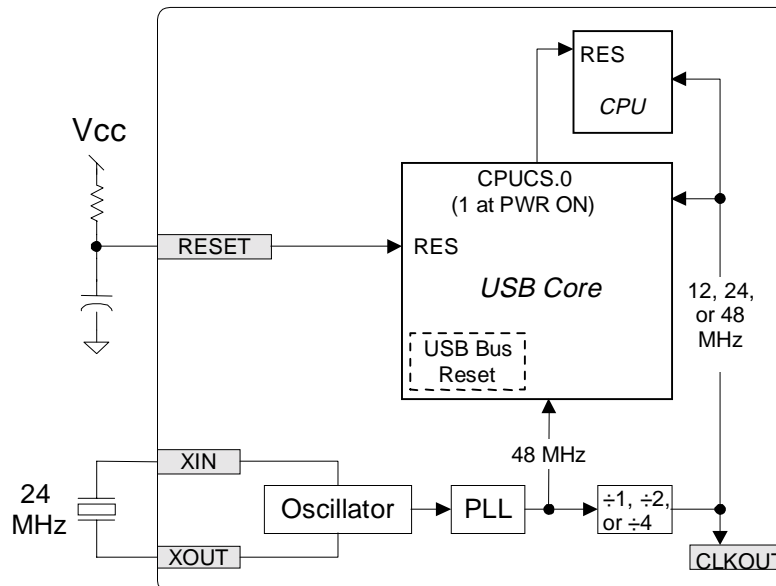

Figure 7-1. EZ-USB FX2 Resets

## 7.2 Power-On Reset (POR)

---

An active-low input pin ( $\overline{\text{RESET}}$ ) resets the FX2 chip. **Note that the term “Power-On Reset” refers to a reset initiated *either* by application of power *or* by assertion of the RESET pin.**

The  $\overline{\text{RESET}}$  pin is normally connected to an external R-C network in order to ensure that, when power is first applied, the FX2 is held in reset until the operating parameters (Vcc voltage, crystal frequency, PLL frequency, etc.) stabilize. The recommended values for the R-C network are a 10K resistor to Vcc and a 1  $\mu\text{F}$  capacitor to GND (see Figure 7-1). External logic can force a POR at any time by pulling the RESET pin low.

Whenever the  $\overline{\text{RESET}}$  pin is asserted, the USB Core holds the CPU in reset.

The CLKOUT pin, crystal oscillator, and PLL are active as soon as power is applied. Once the CPU is out of reset, firmware may clear a control bit (CLKOE, CPUCS.1) to inhibit the CLKOUT output pin for EMI-sensitive applications that do not need this signal.

The CLKOUT signal is active while  $\overline{\text{RESET}}$  is low. When  $\overline{\text{RESET}}$  returns high, the activity on the CLKOUT pin depends on whether or not the FX2 is in the low-power “suspend” state; if it is, CLKOUT stops. Resumption of USB bus activity or assertion of the WAKEUP or WU2 pin (if enabled) restarts the CLKOUT signal.

The oscillator and PLL are unaffected by the state of the  $\overline{\text{RESET}}$  pin.

Power-on default values for all FX2 register bits are shown in *Chapter 15, “Registers”*. At power-on reset:

- Endpoint data buffers and byte counts are uninitialized.
- The CPU clock speed is set to 12 MHz, the CPU is held in reset, and the CLKOUT pin is active.
- All port pins are configured as general-purpose input pins.
- USB interrupts are disabled and USB interrupt requests are cleared.
- Bulk IN and OUT endpoints are unarmed, and their stall bits are cleared. The FX2 will NAK IN and OUT tokens while the CPU is reset.
- Endpoint toggle bits are cleared to 0.
- The RENUM bit is cleared to 0. This means that the Default USB Device, not the firmware, will respond to USB device requests.
- The USB Function Address register is cleared to zero.
- The endpoints are configured for the Default USB Device.
- Interrupt autovectoring is turned off.
- Configuration Zero, Alternate Setting Zero is in effect.



---

## 7.3 Releasing the CPU Reset

---

Register bit CPUCS.0 resets the CPU. This bit is set to 1 at power-on, initially holding the CPU in reset. There are three ways that the CPUCS.0 bit can be cleared to 0, releasing the CPU from reset:

- By the host, as the final step of a RAM download.
- Automatically, at the end of an EEPROM load (assuming the EEPROM is correctly programmed).
- Automatically, when external ROM is used (EA=1) and no “C0” or “C2” EEPROM is present.



*FX2 firmware cannot put the CPU into reset by setting CPUCS.0 to 1; to the firmware, that bit is read-only.*

---

### 7.3.1 RAM Download

Once enumerated, the host can download code into the FX2 RAM using the “Firmware Load” vendor request (*Chapter 2, “Endpoint Zero”*). The last packet loaded writes 0x00 to the CPUCS register, which releases the CPU from reset.

---

### 7.3.2 EEPROM Load

*Chapter 3, “Enumeration and ReNumeration™”* describes the EEPROM boot loads in detail. At power-on, the FX2 checks for the presence of an EEPROM on its I<sup>2</sup>C-compatible bus. If found, it reads the first EEPROM byte. If it reads 0xC2 as the first byte, the FX2 downloads firmware from the EEPROM into internal RAM. The last operation in a “C2” Load writes 0x00 to the CPUCS register, which releases the CPU from reset.

After a “C2” Load, the FX2 sets the RENUM bit to 1, so the firmware will be responsible for responding to USB device requests.

---

### 7.3.3 External ROM

The 128-pin FX2 can use off-chip program memory containing FX2 code and USB device descriptors, which include the VID/DID/PID bytes. Because such a system does not require an I<sup>2</sup>C-compatible EEPROM to supply the VID/DID/PID, the FX2 automatically releases the CPU from reset when:

- The EA pin is pulled high (indicating off-chip code memory), *and*

- No “C0/C2” EEPROM is detected on the I<sup>2</sup>C-compatible bus.

Under these conditions, the FX2 also sets the RENUM bit to 1, so the firmware will be responsible for responding to USB device requests.

---

## 7.4 CPU Reset Effects

---

The USB host may reset the CPU at any time by downloading the value 0x01 to the CPUCS register. The host might do this, for example, in preparation for loading code overlays, effectively magnifying the size of the internal FX2 RAM. For such applications, it is important to know the state of the FX2 chip during and after a CPU reset. In this section, this particular reset is called a “CPU Reset,” and should not be confused with the POR described in Section 7.2, “Power-On Reset (POR).” This discussion applies only to the condition in which the FX2 chip is powered, and the CPU is reset by the host setting the CPUCS.0 bit to 1.

The basic USB device configuration remains intact through a CPU reset. Endpoints keep their configuration, the USB Function Address remains the same, and the I/O ports retain their configurations and values. Stalled endpoints remain stalled, data toggles don’t change, and the RENUM bit is unaffected. The only effects of a CPU reset are as follows:

- USB (INT2) interrupts are disabled, but pending interrupt requests remain pending.
- When the CPU comes out of reset, pending interrupts are kept pending, but disabled. This gives the firmware writer the choice of acting on pre-reset USB events, or ignoring them by clearing the pending interrupt(s) before enabling INT2.
- The breakpoint condition (BREAKPT.3) is cleared.
- While the CPU is in reset, the FX2 will enter the Suspend state automatically if a “suspend” condition is detected on the bus.

---

## 7.5 USB Bus Reset

---

The host signals a USB Bus Reset by driving an SE0 state (both D+ and D- data lines low) for a minimum of 10 ms. The FX2 senses this condition, requests the USB Interrupt (INT2), and supplies the interrupt vector for a USB Reset. After a USB bus reset, the following occurs:

- Toggle bits are cleared to 0.
- The device address is reset to zero.
- If the Default USB Device is active, the USB configuration and alternate settings are reset to zero.
- The FX2 will renegotiate with the host for high-speed (480 Mbps) mode.

Note that the RENUM bit is unchanged after a USB bus reset. Therefore, if a device has ReNumerated™ and loaded a new personality, it retains the new personality through a USB bus reset.

---

## 7.6 FX2 Disconnect

---

Although not strictly a “reset,” the disconnect-reconnect sequence used for ReNumeration™ affects the FX2 in ways similar to the other resets. When the FX2 simulates a disconnect-reconnect, the following occurs:

- Endpoint STALL bits are cleared.
- Data toggles are reset to 0.
- The Function Address is reset to zero.
- If the Default USB Device is active, the USB configuration and alternate settings are reset to zero.

---

## 7.7 Reset Summary

---

Table 7-1. Effects of Various Resets on FX2 Resources (“—” means “no change”)

	RESET Pin	CPU Reset	USB Bus Reset	Disconnect
CPU Reset	Reset	n/a	—	—
IN Endpoints	Unarm	—	—	—
OUT Endpoints	Unarm	—	—	—
Breakpoint	0	0	—	—
Stall Bits	0	—	—	0
Interrupt Enables	0	0	—	—
Interrupt Requests	0	—	—	—
CLKOUT	Active	—	—	—
CPU Clock Speed	12 MHz	—	—	—
Data Toggles	0	—	0	0
Function Address	0	—	0	0
Default USB Device Configuration	0	—	0	0
Default USB Device Alternate Setting	0	—	0	0
RENUM Bit	0	—	—	—



## Chapter 8 Access to Endpoint Buffers

---

### 8.1 Introduction

---

USB data enters and exits FX2 via endpoint buffers. In order to keep up with the high-speed 480 megabit/second transfer rates, *external logic usually reads and writes this data by direct connection to the endpoint FIFOs without any participation by the FX2's CPU.*



*Chapter 9, "Slave FIFOs" and Chapter 10, "General Programmable Interface (GPIF)" give details about how external logic directly connects to the large endpoint FIFOs.*

When an application requires the CPU to process the data as it flows between external logic and the USB — or when there *is* no external logic — firmware can access the endpoint buffers either as blocks of RAM or (using a special auto-incrementing pointer) as a FIFO.

Even when external logic or the built-in General Programmable Interface (GPIF) is handling high-bandwidth data transfers through the four large endpoint FIFOs without any CPU intervention, the firmware has certain responsibilities:

- Configure the endpoints.
- Respond to host requests on CONTROL endpoint zero.
- Optionally make decisions on committing data packets to the USB or external logic.
- Handle all application-specific tasks using its UARTs, counter-timers, interrupts, I/O pins, etc.

### 8.2 FX2 Large and Small Endpoints

---

FX2 endpoint buffers are divided into “small” and “large” groups. EP0 and EP1 are small, 64-byte endpoints which are accessible only by the CPU; they can't be connected directly to external logic.

EP2, EP4, EP6 and EP8 are large, configurable endpoints designed to meet the high-bandwidth requirements of USB 2.0. Although data normally flows through the large endpoint buffers under

control of the FIFO interfaces described in Chapters 9 and 10, the CPU can access the large endpoints if necessary.

---

### 8.3 High-Speed and Full-Speed Differences

---

FX2 operates at both full speed (12 Mbps) and high speed (480 Mbps). The data-payload-size and transfer-speed requirements differ between the two modes. FX2 architecture is optimized for high speed transfers:

- Instead of many small endpoint buffers, FX2 provides a reduced number of large buffers.
- FX2 provides double, triple or quad buffering on its large endpoints (EP2, 4, 6, and 8).
- *The CPU need not participate in high-bandwidth transfers.* Instead, dedicated FX2 logic and unified endpoint/interface FIFOs move data on and off the chip at USB 2.0 rates without any CPU intervention.

FX2 endpoint buffers appear to have different sizes depending on whether the FX2 is operating at full or high speed. This is due to the difference in maximum packet sizes allowed by the USB specification for the two modes, as illustrated by Table 8-1.

Table 8-1. Maximum Packet Sizes for USB 1.1 and 2.0

Transfer Type	Max Packet Size	
	USB 1.1	USB 2.0
CONTROL (EP0 only)	8,16,32,64	64
BULK	8,16,32,64	512
INTERRUPT	1-64	1-1024
ISOCRONOUS	1-1023	1-1024

Although the EP2, EP4, EP6 and EP8 buffers are physically large, they appear as smaller buffers when the FX2 is operating at full speed to account for the smaller maximum packet sizes.

When operating at high speed, firmware can configure the large endpoints' size, type, and buffering; when operating at full speed, type and buffering are configurable but the maximum packet size is always fixed at 64 bytes for the non-isochronous types.

## 8.4 How the CPU Configures the Endpoints

Endpoints are configured via the six registers shown in Table 8-2.

Table 8-2. Endpoint Configuration Registers

Address	Name	Configurable Parameters
0xE610	<b>EP1OUTCFG</b>	valid, type <sup>1</sup> (always OUT, 64 bytes, single-buffered)
0xE611	<b>EP1INCFG</b>	valid, type <sup>1</sup> (always IN, 64 bytes, single-buffered)
0xE612	<b>EP2CFG</b>	valid, direction, type, size, buffering
0xE613	<b>EP4CFG</b>	valid, direction, type (always 512 double-buffered)
0xE614	<b>EP6CFG</b>	valid, direction, type, size, buffering
0xE615	<b>EP8CFG</b>	valid, direction, type (always 512 double-buffered)
Note 1: For EP1, "type" may be set to Interrupt or Bulk only.		



Chapter 15 gives full bit-level details for all registers.

Endpoint 0 does not require a configuration register since it is fixed as valid, IN/OUT, CONTROL, 64 bytes, single-buffered. EP0 uses a single 64-byte buffer both for IN and OUT transfers. EP1 uses separate 64 byte buffers for IN and OUT transfers.

Endpoints 2, 4, 6 and 8 handle the high bandwidth USB 2.0 transfers. Endpoints EP2 and EP6 are the most flexible endpoints, as they are configurable for size (512 or 1024 bytes) and depth of buffering (double, triple, or quad). Endpoints EP4 and EP8 are fixed at 512 bytes, double-buffered.

The bits in these registers control the following:

- **Valid.** Set to 1 (default) to enable the endpoint. A non-valid endpoint does not respond to host IN or OUT packets.
- **Type.** Two bits, TYPE1:0 (bits 5 and 4) set the endpoint type:
  - 00 = *invalid*
  - 01 = ISOCHRONOUS (EP2,4,6,8 only)
  - 10 = BULK (default)
  - 11 = INTERRUPT
- **Direction.** 1 = IN, 0 = OUT.
- **Buffering.** EP2 and EP6 only. Two bits, BUF1:0 control the depth of buffering:
  - 00 = quad

- 01 = *invalid*
- 10 = *double* (default)
- 11 = *triple*

“**Buffering**” refers to the number of RAM blocks available to the endpoint. With double buffering, for example, USB data can fill or empty an endpoint buffer at the same time that another packet from the same endpoint fills or empties from the external logic. This technique maximizes performance by saving each side, USB and external-logic interface, from waiting for the other side. Multiple buffering is most effective when the providing and consuming rates are comparable but bursty (as is the case with USB and many other interfaces, such as disk drives). Assigning more RAM blocks (triple and quad buffering) provides more “smoothing” of the bursty data rates. A simple way to determine the appropriate buffering depth is to start with the minimum, then increase it until no NAKs appear on the USB side and no wait states appear on the interface side.

---

## 8.5 CPU Access to FX2 Endpoint Data

---

Endpoint data is visible to the CPU at the addresses shown in Table8-3. Whenever the application calls for endpoint buffers smaller than the physical buffer sizes shown in Table8-3, the CPU accesses the endpoint data starting from the lowest address in the buffer. For example, if EP2 has a reported MaxPacketSize of 512 bytes, the CPU accesses the data in the lower portion of the EP2 buffer (i.e., from 0xF000 to 0xF1FF). Similarly, if the FX2 is operating in full speed mode (which dictates a maximum Bulk packet size of only 64 bytes), only the lower 64 bytes of the endpoint (i.e., 0xF000-0xF03F for EP2) will be used for Bulk data.

Table 8-3. Endpoint Buffers in RAM Space

Name	Address	Size (bytes)
<b>EPOBUF</b>	0xE740-0xE77F	64
<b>EP1OUTBUF</b>	0xE780-0xE7BF	64
<b>EP1INBUF</b>	0xE7C0-0xE7FF	64
<b>EP2FIFOBUF</b>	0xF000-0xF3FF	1024
<b>EP4FIFOBUF</b>	0xF400-0xF5FF	512
<b>EP6FIFOBUF</b>	0xF800-0xFBFF	1024
<b>EP8FIFOBUF</b>	0xFC00-0xFDFF	512



*EPOBUF is for the (optional) data stage of a CONTROL transfer. The eight bytes of data from the CONTROL packet appear in a separate FX2 RAM buffer called SETUPDAT, at 0xE6B8-0xE6BF.*

The CPU can only access the “active” buffer of a multiple-buffered endpoint. In other words, firmware must treat a quad-buffered 512-byte endpoint as being only 512 bytes wide, even though the quad-buffered endpoint actually occupies 2048 bytes of RAM. Also, when EP2 and EP6 are configured such that EP4 and/or EP8 are unavailable, the firmware must never attempt to access the buffers corresponding to those unavailable endpoints.



For example, if EP2 is configured for triple-buffered 1024-byte operation, the firmware should access EP2 only at 0xF000-0xF3FF. The firmware should not access the EP4 or EP6 buffers in this configuration, since they don't exist (the RAM space which they would normally occupy is used to implement the EP2 triple-buffering).

---

## 8.6 CPU Control of FX2 Endpoints

---

From the CPU's point of view, the "small" and "large" endpoints operate slightly differently, due to the multiple-packet buffering scheme used by the large endpoints.

The CPU uses internal registers to control the flow of endpoint data. Since the small endpoints EP0 and EP1 are programmed differently than the large endpoints EP2, EP4, EP6, and EP8, these registers fall into three categories:

- Registers that apply to the small endpoints (EP0, EP1IN, and EP1OUT)
- Registers that apply to the large endpoints (EP2, EP4, EP6, and EP8)
- Registers that apply to both sets of endpoints

---

### 8.6.1 Registers That Control EP0, EP1IN, and EP1OUT

Table 8-4. Registers that control EP0 and EP1

Address	Name	Function
0xE6A0	<b>EP0CS</b>	EP0 HSNACK, Busy, Stall
0xE68A	<b>EP0BCH</b>	EP0 Byte Count (MSB)
0xE68B	<b>EP0BCL</b>	EP0 Byte Count (LSB)
0xE65C	<b>USBIE</b>	EP0 Interrupt Enables
0xE65D	<b>USBIRQ</b>	EP0 Interrupt Requests
SFR 0xBA	<b>EP01STAT</b>	Endpoint 0 and 1 Status
0xE6A1	<b>EP1OUTCS</b>	EP1OUT Busy, Stall
0xE68D	<b>EP1OUTBC</b>	EP1OUT Byte Count
0xE6A2	<b>EP1INCS</b>	EP1IN Busy, Stall
0xE68F	<b>EP1INBC</b>	EP1IN Byte Count

#### 8.6.1.1 EP0CS

Firmware uses this register to coordinate CONTROL transfers over endpoint 0. The EP0CS register contains three bits: **HSNACK**, **BUSY** and **STALL**.

## HSNAK

HSNAK is automatically set to 1 whenever the SETUP token of a CONTROL transfer arrives. The FX2 logic automatically NAKs the STATUS (handshake) stage of the CONTROL transfer until the firmware clears the HSNAK bit *by writing "1" to it*. This mechanism gives the firmware a chance to hold off subsequent transfers until it completes the actions required by the CONTROL transfer.



*Firmware must clear the HSNAK bit after servicing every CONTROL transfer.*

## BUSY

The read-only BUSY bit is relevant only for the data stage of a CONTROL transfer. BUSY=1 indicates that the endpoint is currently being serviced by USB, so firmware should not access the endpoint data.

BUSY is automatically cleared to 0 whenever the SETUP token of a CONTROL transfer arrives. The BUSY bit is set to 1 under different conditions for IN and OUT transfers.

For IN transfers, FX2 logic will NAK all IN0 tokens until the firmware has “armed” EP0 for IN transfers by writing to the EP0BCH:L Byte Count register, which sets BUSY=1 to indicate that firmware should not access the data. Once the endpoint data is sent and acknowledged, BUSY is automatically cleared to 0 and the EP0IN interrupt request bit is asserted. After BUSY is automatically cleared to 0, the firmware may refill the EP0IN buffer.

For OUT transfers, FX2 logic will NAK all OUT0 tokens until the firmware has “armed” EP0 for OUT transfers by writing any value to the EP0BCL register. BUSY is automatically set to 1 when the firmware writes to EP0BCL, and BUSY is automatically cleared to 0 after the data has been correctly received and ACK'd. When BUSY transitions to zero, the FX2 also generates an EP0OUT interrupt request.



*The FX2's autovectorred interrupt system automatically transfers control to the appropriate ISR (Interrupt Service Routine) for the endpoint requiring service. Chapter 4, "Interrupts" describes this mechanism.*

## STALL

Set STALL=1 to instruct the FX2 to return the STALL response to a CONTROL transfer. This is generally done when the firmware does not recognize an incoming USB request. According to the USB spec, endpoint zero must always accept transfers, so STALL is automatically cleared to 0 whenever a SETUP token arrives. If it's desired to stall a transfer and also clear HSNAK to 0 (by writing a 1 to it), the firmware should set STALL=1 first, in order to ensure that the STALL bit is set before the “acknowledge” phase of the CONTROL transfer can complete.

### 8.6.1.2 EP0BCH and EP0BCL

These are the byte count registers for bytes sent as the optional data stage of a CONTROL transfer. Although the EP0 buffer is only 64 bytes wide, the byte count registers are 16 bits wide to allow using the Setup Data Pointer to send USB IN data records that consist of multiple packets.

To use the Setup Data Pointer in its most-general mode, firmware clears the SUDPTR AUTO bit and writes the address of a data block into the Setup Data Pointer, then loads the EP0BCH:L registers with the total number of bytes to transfer. The FX2 automatically transfers the entire block, partitioning the data into MaxPacketSize packets as necessary.



*The Setup Data Pointer is the subject of Section 8.8.*

For IN transfers *without* using the Setup Data Pointer, firmware loads data into EP0BUF, then writes the number of bytes to transfer into EP0BCH and EP0BCL. The packet is armed for IN transfer when the firmware writes to EP0BCL, so EP0BCH should always be loaded first. These transfers are always 64 bytes or less, so EP0BCH must be loaded with 0 (and EP0BCL must be in the range [0-63]). EP0BCH will hold that zero value until firmware overwrites it.

For EP0 OUT transfers, the byte count registers indicate the number of bytes received in EP0BUF. Byte counts for EP0 OUT transfers are always 64 or fewer, so EP0BCH is always zero after an OUT transfer. To re-arm the EP0 buffer for a future OUT transfer, the firmware simply writes any value to EP0BCL.

### 8.6.1.3 USBIE, USBIRQ

Three interrupts — SUTOK, SUDAV, and EP0ACK — are used to manage CONTROL transfers over endpoint zero. The individual enables for these three interrupt sources are in the USBIE register, and the interrupt-request flags are in the USBIRQ register.

Each of the three interrupts signals the completion of a different stage of a CONTROL transfer.

- **SUTOK** (“Setup Token”) asserts when FX2 receives the SETUP token.
- **SUDAV** (“Setup Data Available”) asserts when FX2 logic has loaded the eight bytes from the SETUP stage into the 8-byte buffer at SETUPDAT.
- **EP0ACK** (“Endpoint Zero Acknowledge”) asserts when the handshake stage has completed.

The SUTOK interrupt is not normally used; it is provided for debug and diagnostic purposes. Firmware generally services the CONTROL transfer by responding to the SUDAV interrupt, since this interrupt fires only after the 8 setup bytes are available for examination in the SETUPDAT buffer.

#### 8.6.1.4 EP01STAT

The BUSY bits in EP0CS, EP1OUTCS, and EP1INCS (described later in this chapter) are replicated in this SFR; they are provided here in order to allow faster access (via the MOV instruction rather than MOVX) to those bits.

Three status bits are provided in the EP01STAT register; the status bits are the following:

- EP1INBSY: 1 = EP1IN is busy
- EP1OUTBSY: 1 = EP1OUT is busy
- EP0BSY: 1 = EP0 is busy

#### 8.6.1.5 EP1OUTCS

This register is used to coordinate BULK or INTERRUPT transfers over EP1OUT. The EP1OUTCS register contains two bits, **BUSY** and **STALL**.

##### **BUSY**

This bit indicates when the firmware can read data from the Endpoint 1 OUT buffer. BUSY=1 means that the SIE “owns” the buffer, so firmware should not read (or write) the buffer. BUSY=0 means that the firmware may read from (or write to) the buffer. A 1-to-0 BUSY transition asserts the EP1OUT interrupt request, signaling that new EP1OUT data is available.

BUSY is automatically cleared to 0 after the FX2 verifies the OUT data for accuracy and ACKs the transfer. If a transmission error occurs, the FX2 automatically retries the transfer; error recovery is transparent to the firmware.

Firmware arms the endpoint for OUT transfers by writing any value to the byte count register EP1BC, which automatically sets BUSY=1.

At power-on (or whenever a 0-to-1 transition occurs on the RESET pin), the BUSY bit is set to 0, so the FX2 will NAK all EP1OUT transfers until the firmware arms EP1OUT by writing any value to EP1BC.



##### **EZ-USB / EZ-USB FX Programmers:**

*The power-on state of all FX2 endpoint BUSY bits is zero, in contrast to EZ-USB and EZ-USB FX, whose BUSY bits for OUT endpoints default to one. This means that FX2 firmware must arm OUT endpoints prior to using them (EZ-USB and EZ-USB FX accept one OUT transfer before the OUT endpoint must be armed).*

## **STALL**

Firmware sets **STALL=1** to instruct the FX2 to return the **STALL PID** (instead of **ACK** or **NAK**) in response to an **EP1OUT** transfer. The FX2 will continue to respond to **EP1OUT** transfers with the **STALL PID** until the firmware clears this bit.

### **8.6.1.6 EP1OUTBC**

Firmware may read this 7-bit register to determine the number of bytes (0-64) in **EP1OUTBUF**.

Firmware writes any value to **EP1OUTBC** to arm an **EP1OUT** transfer.

### **8.6.1.7 EP1INCS**

This register is used to coordinate **BULK** or **INTERRUPT** transfers over **EP1IN**. The **EP1INCS** register contains two bits, **BUSY** and **STALL**.

#### **BUSY**

This bit indicates when the firmware can load data into the Endpoint 1 IN buffer. **BUSY=1** means that the SIE “owns” the buffer, so firmware should not write (or read) the buffer. **BUSY=0** means that the firmware may write data into (or read from) the buffer. A 1-to-0 **BUSY** transition asserts the **EP1IN** interrupt request, signaling that the **EP1IN** buffer is free and ready to be loaded with new data.

The firmware schedules an IN transfer by loading up to 64 bytes of data into **EP1INBUF**, then writing the byte count register **EP1INBC** with the number of bytes loaded (0-64). Writing the byte count register automatically sets **BUSY=1**, indicating that the transfer over USB is pending. After the FX2 subsequently receives an IN token, sends the data, and successfully receives an **ACK** from the host, **BUSY** is automatically cleared to 0 to indicate that the buffer is ready to accept more data. This generates the **EP1IN** interrupt request, which signals that the buffer is again available.

At power-on, or whenever a 0-to-1 transition occurs on the **RESET** pin, the **BUSY** bit is set to 0, meaning that the FX2 will **NAK** all **EP1IN** transfers until the firmware arms the endpoint by writing the number of bytes to transfer into the **EP1BC** register.

## **STALL**

Firmware sets **STALL=1** to instruct the FX2 to return the **STALL PID** (instead of **ACK** or **NAK**) in response to an **EP1IN** transfer. The FX2 will continue to respond to **EP1IN** transfers with the **STALL PID** until the firmware clears this bit.

### **8.6.1.8 EP1INBC**

Firmware arms an IN transfer by loading this 7-bit register with the number of bytes (0-64) it has previously loaded into **EP1INBUF**.

## 8.6.2 Registers That Control EP2, EP4, EP6, EP8

In order to achieve the high transfer bandwidths required by USB 2.0's high-speed mode, the FX2's CPU should not participate in transfers to and from the "large" endpoints. Instead, those endpoints are usually connected directly to external logic (see *Chapter 9* and *Chapter 10* for details).

Some applications, however, may require the firmware to have at least some small amount of control over the large endpoints. For those applications, the FX2 provides the registers shown in Table 8-5.

Table 8-5. Registers that control EP2, EP4, EP6 and EP8

Address	Name	Function
SFR 0xAA	<b>EP2468STAT</b>	EP2, 4, 6, 8 empty/full
0xE648	<b>INPKTEND</b>	force end of IN packet
0xE640	<b>EP2ISOINPKTS</b>	ISO IN packets per frame or microframe
0xE6A3	<b>EP2CS</b>	npak, full, empty, stall
0xE690	<b>EP2BCH</b>	byte count (H)
0xE691	<b>EP2BCL</b>	byte count (L)
0xE641	<b>EP4ISOINPKTS</b>	ISO IN packets per frame or microframe
0xE6A4	<b>EP4CS</b>	npak, full, empty, stall
0xE694	<b>EP4BCH</b>	byte count (H)
0xE695	<b>EP4BCL</b>	byte count (L)
0xE642	<b>EP6ISOINPKTS</b>	ISO IN packets per frame/microframe
0xE6A5	<b>EP6CS</b>	npak, full, empty, stall
0xE698	<b>EP6BCH</b>	byte count (H)
0xE699	<b>EP6BCL</b>	byte count (L)
0xE643	<b>EP8ISOINPKTS</b>	ISO IN packets per frame/microframe
0xE6A6	<b>EP8CS</b>	npak, full, empty, stall
0xE69C	<b>EP8BCH</b>	byte count (H)
0xE69D	<b>EP8BCL</b>	byte count (L)

### 8.6.2.1 EP2468STAT

The Endpoint Full and Endpoint Empty status bits (described below, in Section 8.6.2.3) are replicated here in order to allow faster access by the firmware.

### 8.6.2.2 EP2ISOINPKTS, EP4ISOINPKTS, EP6ISOINPKTS, EP8ISOINPKTS

For high-speed (480 Mbps) ISOCHRONOUS IN endpoints only, the **INPPF1** and **INPPF0** bits in each of these registers determine the number of packets per microframe.

These registers do not affect full-speed (12 Mbps) operation; full-speed isochronous transfers are always fixed at one packet per frame.

Table 8-6. Isochronous IN Packets per Microframe, High-Speed Only

INPPF1	INPPF0	Packets
0	0	Invalid
0	1	1
1	0	2
1	1	3

### 8.6.2.3 EP2CS, EP4CS, EP6CS, EP8CS

Because the four large FX2 endpoints offer double, triple or quad buffering, a single BUSY bit is not sufficient to convey the state of these endpoint buffers. Therefore, these endpoints have multiple bits (NPAK, FULL, EMPTY) that can be inspected in order to determine the state of the endpoint buffers.



Multiple-buffered endpoint data must be read or written **only** at the buffer addresses given in Table 8-3. The FX2 automatically switches the multiple buffers in and out of the single addressable buffer space.

#### NPAK[2:0] (EP2, EP6) and NPAK[1:0] (EP4, EP8)

NPAK values have different interpretations for IN and OUT endpoints:

- **OUT Endpoints:** NPAK indicates the number of packets received over USB and ready for the firmware to read.
- **IN Endpoints:** NPAK indicates the number of IN packets committed to USB (i.e., loaded and armed for USB transfer), and thus *unavailable* to the firmware.

The NPAK fields differ in size to account for the depth of buffering available to the endpoints. Only double buffering is available for EP4 and EP8 (two NPAK bits), and up to quad buffering is available for EP2 and EP6 (three NPAK bits).

#### FULL

While FULL and EMPTY apply to transfers in both directions, “FULL” is more useful for IN transfers. It has the same meaning as “BUSY”, but applies to multiple-buffered IN endpoints. FULL=1 means that all buffers are committed to USB, and none are available for firmware access.

For IN transfers, FULL=1 means that all buffers are committed to USB, so firmware should not load the endpoint buffer with any more data. When FULL=1, NPAK will hold 2, 3 or 4, depending on the buffering depth (double, triple or quad). This indicates that all buffers are in use by the USB

transfer logic. As soon as one buffer becomes available, FULL will be cleared to 0 and NPAK will decrement by one, indicating that all but one of the buffers are committed to USB (i.e., one is available for firmware access). As IN buffers are transferred over USB, NPAK decrements to indicate the number still pending, until all are sent and NPAK=0.

## EMPTY

While FULL and EMPTY apply to transfers in both directions, EMPTY is more useful for OUT transfers. EMPTY=1 means that the buffers are empty; all received packets (2, 3, or 4, depending on the buffering depth) have been serviced.

## STALL

Firmware sets STALL=1 to instruct the FX2 to return the STALL PID (instead of ACK or NAK) in response to an IN or OUT transfer. The FX2 will continue to respond to IN or OUT transfers with the STALL PID until the firmware clears this bit.

### 8.6.2.4 EP2BCH:L, EP4BCH:L, EP6BCH:L, EP8BCH:L

Endpoints EP2 and EP6 have 11-bit byte count registers to account for their maximum buffer sizes of 1024 bytes. Endpoints EP4 and EP8 have 10-bit byte count registers to account for their maximum buffer sizes of 512 bytes.

The byte count registers function similarly to the EP0 and EP1 byte count registers:

- For an IN transfer, the firmware loads the byte count registers to arm the endpoint (if EPxBCH must be loaded, it should be loaded first, since the endpoint is armed when EPxBCL is loaded).
- For an OUT transfer, the firmware reads the byte count registers to determine the number of bytes in the buffer, then writes any value to the low byte count register to re-arm the endpoint. See the “Skip” section, below, for further details.



*The EP0BCH register must be initialized on reset, since its power-on-reset state is undefined.*

## SKIP

Normally, the CPU interface and outside-logic interface to the endpoint FIFOs are independent, with separate sets of control bits for each interface. The AUTOOUT mode and the SKIP bit implement an “overlap” between these two domains. A brief introduction to the AUTOOUT mode is given below; full details appear in *Chapter 9, “Slave FIFOs.”*

When outside logic is connected to the interface FIFOs, the normal data flow is for the FX2 automatically to commit OUT data packets to the outside interface FIFO as they become available. This ensures an uninterrupted flow of OUT data from the host to the outside world, and preserves the high bandwidth required by high speed mode.



In some cases, it may be desirable to insert a “hook” into this data flow, so that -- rather than the FX2 automatically committing the packets to the outside interface as they are received over USB, firmware receives an interrupt for every received OUT packet, then has the option to either commit the packet to the outside interface (the “output FIFO”), or discard it. The firmware might, for example, inspect a packet header to make this skip/commit decision.

To enable this “hook”, the AUTOOUT bit is cleared to 0. If AUTOOUT = 0 and an OUT endpoint is re-armed by writing to its low byte-count register, the actual value written to the register becomes significant:

- If the SKIP bit (bit 7 of each EPxBCL register) is cleared to 0, the packet will be committed to the output FIFO and thereby made available to the external logic.
- If the SKIP bit is set to 1, the just-received OUT packet will not be committed to the output FIFO for transfer to the external logic; instead, the packet will be ignored, its buffer will immediately be made available for the next OUT packet, and the output FIFO (and external logic) will never even “know” that it arrived.



*The AUTOOUT bit appears in bit 4 of the Endpoint FIFO Configuration Registers EP2FIFOCFG, EP4FIFOCFG, EP6FIFOCFG and EP8FIFOCFG.*

### 8.6.3 Registers That Control All Endpoints

*Table 8-7. Registers that control all endpoints*

0xE658	<b>IBNIE</b>	IN-BULK-NAK individual interrupt enables
0xE659	<b>IBNIRQ</b>	IN-BULK-NAK individual interrupt requests
0xE65A	<b>NAKIE</b>	PING plus combined IBN-interrupt enable
0xE65B	<b>NAKIRQ</b>	PING plus combined IBN-interrupt request
0xE65C	<b>USBIE</b>	SUTOK, SUDAV, EP0-ACK, SOF interrupt enables
0xE65D	<b>USBIRQ</b>	SUTOK, SUDAV, EP0-ACK, and SOF interrupt requests
0xE65E	<b>EPIE</b>	Endpoint interrupt enables
0xE65F	<b>EPIRQ</b>	Endpoint interrupt requests
0xE662	<b>USBERRIE</b>	USB error interrupt enables
0xE663	<b>USBERRIE</b>	USB error interrupt requests
0xE664	<b>ERRCNTLIM</b>	USB error counter and limit
0xE665	<b>CLRERRCNT</b>	Clear error count
0xE683	<b>TOGCTL</b>	EP0/EP1 data toggle

### 8.6.3.1 IBNIE, IBNIRQ, NAKIE, NAKIRQ

These registers contain the interrupt-enable and interrupt-request bits for two endpoint conditions, **IN-BULK-NAK** and **PING**.

#### IN-BULK-NAK (IBN)

When the host requests an IN packet from an FX2 BULK endpoint, the endpoint NAKs (returns the NAK PID) until the endpoint buffer is filled with data and armed for transfer, at which point the FX2 answers the IN request with data.

Until the endpoint is loaded and armed, a flood of IN-NAKs can tie up bus bandwidth. Therefore, if the IN endpoints aren't always kept full and armed, it may be useful to know when the host is "knocking at the door", requesting IN data.

The IN-BULK-NAK (IBN) interrupt provides this notification. The IBN interrupt fires whenever a BULK endpoint NAKs an IN request. The IBNIE/IBNIRQ registers contain individual enable and request bits per endpoint, and the NAKIE/NAKIRQ registers each contain a single bit, IBN, that is the OR'd combination of the individual bits in IBNIE/IBNIRQ, respectively.

Firmware enables an interrupt by setting the enable bit high, and clears an interrupt request bit by writing a 1 to it.



*The FX2 interrupt system is described in detail in Chapter 4, "Interrupts."*

The IBNIE register contains an individual interrupt-enable bit for each endpoint: EP0, EP1, EP2, EP4, EP6 and EP8. These bits are valid only if the endpoint is configured as a BULK or INTERRUPT endpoint. The IBNIRQ register similarly contains individual interrupt request bits for the 6 endpoints.

The IBN interrupt-service routine should take the following actions, in the order shown:

1. Clear the USB (INT2) interrupt request (by writing 0 to it).
2. Inspect the endpoint bits in IBNIRQ to determine which IN endpoint just NAK'd.
3. Take the required action (set a flag, arm the endpoint, etc.), then clear the individual IBN bit in IBNIRQ for the serviced endpoint (by writing 1 to it).
4. Repeat steps (2) and (3) for any other endpoints that require IBN service, until all IRQ bits are cleared.
5. Clear the IBN bit in the NAKIRQ register (by writing 1 to it).



*Because the IBN bit represents the OR'd combination of the individual IBN interrupt requests, it will not "fire" again until all individual IBN interrupt requests have been serviced and cleared.*

## PING

PING is the “flip side” of IBN; it’s used for high speed (480 Mbits/sec) BULK OUT transfers.

When operating at full speed (USB 1.1 spec), every host OUT transfer consists of the OUT PID *and the endpoint data*, even if the endpoint is NAKing (not ready). While the endpoint is not ready, the host repeatedly sends all the OUT data; if it’s repeatedly NAK’d, bus bandwidth is wasted.

USB 2.0 introduced a new mechanism, called PING, that makes better use of bus bandwidth for “unready” BULK OUT endpoints.

At high speed (USB 2.0 spec), the host can “ping” a BULK OUT endpoint to determine if it is ready to accept data, *holding off the OUT data transfer until it can actually be accepted*. The host sends a PING token, and the FX2 responds with:

- An ACK to indicate that there is space in the OUT endpoint buffer
- A NAK to indicate “not ready, try later”.

The PING interrupts indicate that an FX2 BULK OUT endpoint returned a NAK in response to a PING.



*PING only applies at high speed (480 Mbits/sec).*

Unlike the IBN bits, which are combined into a single IBN interrupt for all endpoints, each BULK OUT endpoint has a separate interrupt (EP0PING, EP1PING, EP2PING, ..., EP8PING). Interrupt-enables for the individual interrupts are in the NAKIE register; the interrupt-requests are in the NAKIRQ register.

The interrupt service routine for the PING interrupts should perform the following steps, in the order shown:

1. Clear the INT2 interrupt request.
2. Take the action for the requesting endpoint.
3. Clear the appropriate EPxPING bit for the endpoint.

### 8.6.3.2 EPIE, EPIRQ

These registers are used to manage interrupts from the FX2 endpoints. In general, an interrupt request is asserted whenever the following occurs:

- An IN endpoint buffer becomes available for the CPU to load.
- An OUT endpoint has new data for the CPU to read.

For the small endpoints (EP0 and EP1IN/OUT), these conditions are synonymous with the endpoint BUSY bit making a 1-to-0 transition (busy to not-busy). As with all FX2 interrupts, this one is enabled by writing a “1” to its enable bit, and the interrupt flag by writing a “1” to it.



**Do not** attempt to clear an IRQ bit by reading the IRQ register, ORing its contents with a bit mask (e.g. 00010000), then writing the contents back to the register. Since a “1” clears an IRQ bit, this clears **all** the asserted IRQ bits rather than just the desired one. Instead, simply write a single “1” (e.g., 00010000) to the register.

### 8.6.3.3 USBERRIE, USBERRIRQ, ERRCNTLIM, CLRERRCNT

These registers are used to monitor the “health” of the USB connection between the FX2 and the host.

#### USBERRIE

This register contains the interrupt-enable bits for the “Isochronous Endpoint Error” interrupts and the “USB Error Limit” interrupt.

An “Isochronous Endpoint Error” occurs when the FX2 detects a PID sequencing error for a high-bandwidth, high-speed ISO endpoint.

#### USBERRIRQ

This register contains the interrupt flags for the “Isochronous Endpoint Error” interrupts and the “USB Error Limit” interrupt.

#### ERRCNTLIM

FX2 firmware sets the USB error limit to any value from 1 to 15 by writing that value to the lower nibble of this register; when that many USB errors (CRC errors, Invalid PIDs, garbled packets, etc.) have occurred, the “USB Error Limit” interrupt flag will be set. At power-on-reset, the error limit defaults to 4 (0100 binary).

The upper nibble of this register contains the current USB error count.

#### CLRERRCNT

Writing any value to this register clears the error count in the upper nibble of ERRCNTLIM. The lower nibble of ERRCNTLIM is not affected.

### 8.6.3.4 TOGCTL

As described in *Chapter 1, “Introducing EZ-USB FX2”* the host and device maintain a *data toggle* bit, which is toggled between data packet transfers. There are certain times when the firmware must reset an endpoint’s data toggle bit to 0:

- After a configuration changes (i.e., after the host issues a *Set Configuration* request).
- After an interface's alternate setting changes (i.e., after the host issues a *Set Interface* request).
- After the host sends a *Clear Feature - Endpoint Stall* request to an endpoint.

For the first two, the firmware must clear the data toggle bits for all endpoints contained in the affected interfaces. For the third, only one endpoint's data toggle bit is cleared.

The TOGCTL register contains bits to set or clear an endpoint data toggle bit, as well as to read the current state of a toggle bit.



*At this writing, there is no known reason for firmware to set an endpoint toggle to "1". Also, since the FX2 handles all data toggle management, normally there is no reason to know the state of a data toggle. These capabilities are included in the TOGCTL register for completeness and debug purposes.*

TOGCTL							Data Toggle Control	E683
b7	b6	b5	b4	b3	b2	b1	b0	
<b>Q</b>	<b>S</b>	<b>R</b>	<b>IO</b>	<b>EP3</b>	<b>EP2</b>	<b>EP1</b>	<b>EP0</b>	
R	R/W	R/W	R/W	R/W	R/W	R/W	R/W	
x	x	x	x	x	x	x	x	

A two-step process is employed to clear an endpoint data toggle bit to 0. First, writes the TOGCTL register with an endpoint address (EP3:EP0) plus a direction bit (IO). Then, keeping the endpoint and direction bits the same, write a "1" to the R (reset) bit. For example, to clear the data toggle for EP6 configured as an "IN" endpoint, write the following values sequentially to TOGCTL:

- 00010110
- 00110110

---

## 8.7 The Setup Data Pointer

---

The USB host sends device requests using CONTROL transfers over endpoint 0. Some requests require the FX2 to return data over EP0. During enumeration, for example, the host issues *Get Descriptor* requests that ask for the device's capabilities and requirements. The returned data can span many packets, so it must be partitioned into packet-sized blocks, then the blocks must be sent at the appropriate times (i.e., when the EP0 buffer becomes ready).

The Setup Data Pointer automates this process of returning IN data over EP0, simplifying the firmware.



For the Setup Data Pointer to work properly, EP0's *MaxPacketSize* **must** be set to 64.

Table 8-8 lists the registers which configure the Setup Data Pointer.

Table 8-8. Registers used to control the Setup Data Pointer

Address	Register Name	Function
0xE6B3	SUDPTRH	High address
0xE6B4	SUDPTL	Low address
0xE6B5	SUDPTRCTL	SDPAUTO bit

To send a block of data, the block's starting address is loaded into SUDPTRH:L. The block length must previously have been set; the method for accomplishing this depends on the state of the SDPAUTO bit:

- **SDPAUTO = 0 (Manual Mode):** Used for general-purpose block transfers. Firmware writes the block length to EP0BCH:L.
- **SDPAUTO = 1 (Auto Mode):** Used for sending Device, Configuration, String, Device Qualifier, and Other Speed Configuration descriptors *only*. The block length is automatically read from the "length" field of the descriptor itself; no explicit loading of EP0BCH:L is necessary.

Writing to SUDPTL starts the transfer; the FX2 automatically sends the entire block, packetizing as necessary.

For example, to answer a *Get Descriptor - Device* request, firmware sets SDPAUTO = 1, then loads the address of the device descriptor into SUDPTRH:L. The FX2 then automatically loads the EP0 data buffer with the required number of packets and transfers them to the host.

To command the FX2 to ACK the status (handshake) packet, the firmware clears the HSNACK bit (by writing 1 to it) before starting the Setup Data Pointer transfer.

If the firmware needs to know when the transaction is complete (i.e., sent and acknowledged), it can enable the EP0ACK interrupt before starting the Setup Data Pointer transfer.



When SDPAUTO = 0, writing to EP0BCH:L only sets the block length; it does not arm the transfer (the transfer is armed by writing to SUDPTL). Therefore, before performing an EP0 transfer which does **not** use the Setup Data Pointer (i.e., one which is meant to be armed by writing to EP0BCL), SDPAUTO **must** be set to 1.

---

### 8.7.1 Transfer Length

When the host makes any EP0IN request, the FX2 respects the following two length fields:

- the requested number of bytes (from the last two bytes of the SETUP packet received from the host)
- the available number of bytes, supplied either as a length field in the actual descriptor (SDPAUTO=1) or in EP0BCH:L (SDPAUTO=0)

In accordance with the USB Specification, the FX2 sends the *smaller* of these two length fields.

---

### 8.7.2 Accessible Memory Spaces

The Setup Data Pointer can access data in either of two RAM spaces:

- On-chip Main RAM (8 KB at 0x0000-0x1FFF)
- On-chip Scratch RAM (512 bytes at 0xE000-0xE1FF)



*The Setup Data Pointer cannot be used to access off-chip memory at any address.*

---

## 8.8 Autopointers

---

Endpoint data is available to the CPU in RAM buffers (see Table 8-3). In some cases, it is faster for the firmware to access endpoint data as though it were in a FIFO register. The FX2 provides two special data pointers, called “Autopointers”, that automatically increment after each byte transfer. Using the Autopointers, firmware can access contiguous blocks of on- or off-chip data memory as a FIFO.

Each Autopointer is controlled by a 16-bit address register (AUTOPTRNH:L), a data register (AUTODATn/XAUTODATn), and a control bits (APTRnINC). An additional control bit, EXTACC, applies to both Autopointers.

A read from (or write to) an Autopointer data register *actually* accesses the address pointed to by the corresponding Autopointer address register, which increments on every data-register access. To read or write a contiguous block of memory (for example, an endpoint buffer) using an Autopointer, load the Autopointer’s address register with the starting address of the block, then repeatedly read or write the Autopointer’s data register.

The AUTOPTRNH:L registers may be written or read at any time to determine the current Autopointer address.

Most of the Autopointer registers are in SFR Space for quick access; the data registers are available *both* in SFR Space and in External Data space, as explained below.

Table 8-9. Registers that control the Autopointers

Address	Register Name	Function
SFR 0xAF	<b>AUTOPTTRSETUP</b>	Increment/freeze, off-chip access enable
SFR 0x9A	<b>AUTOPTTR1H</b>	Address high
SFR 0x9B	<b>AUTOPTTR1L</b>	Address low
SFR 0x9C	<b>AUTODAT1</b>	Data (on-chip data access)
0xE67B	<b>XAUTODAT1</b>	Data (on- or off-chip data access)
SFR 0x9D	<b>AUTOPTTR2H</b>	Address high
SFR 0x9E	<b>AUTOPTTR2L</b>	Address low
SFR 0x9F	<b>AUTODAT2</b>	Data (on-chip data access)
0xE67C	<b>XAUTODAT2</b>	Data (on- or off-chip data access)

The Autopointers are configured using three bits in the AUTOPTTRSETP register: two bits (one for each Autopointer, called APTR1INC and APTR2INC, respectively) control whether or not the address increments for every Autodata access, and one bit (EXTACC) controls whether or not the XAUTODATn registers are used to access off-chip data.

To access on-chip data memory using the Autopointers, use the SFR registers AUTODAT1/2. The AUTODATn registers can **only** be used to access on-chip FX2 memory, *and they do so regardless of the EXTACC setting.*

To access off-chip data memory, set EXTACC=1, then use the XAUTODATn registers. This has one side effect: Any *code* access (an instruction fetch, for instance) from addresses 0xE67B and 0xE67C will return the AUTODATA values, rather than the code-memory values at these two addresses. This introduces a two-byte “hole” in the code memory. If this is undesirable in the application, simply restrict Autopointer access to on-chip data memory by setting EXTACC=0, the default.



*There is no two-byte hole in the **data** memory at 0xE67B:E67C; the hole only appears in the **program** memory.*

Proper selection of the AUTODATn or XAUTODATn registers for an application can be summarized as follows:

- Reference the memory maps in *Chapter 5, “Memory”* to determine whether the memory referenced by the Autopointer is on-chip or off-chip.
- If the Autopointers will reference on-chip data memory, use the AUTODATn registers.



- If the Autopointers will reference off-chip data memory, set EXTACC=1, then use the XAUTODATn registers. This introduces a two-byte hole in External Program memory at addresses 0xE67B and 0xE67C.
- In either case, the Autopointers can be set to auto-increment via the APTRnINC bits in the AUTOPTRSETUP register.

An Autopointer whose auto-increment feature has been disabled (i.e., APTRnINC = 0) can be useful, as it allows faster polling (via the MOV instruction, rather than MOVX) of FX2 registers in External Data memory.



## Chapter 9 Slave FIFOs

---

### 9.1 Introduction

---

Although some FX2-based devices may use the FX2's CPU to process USB data directly (see *Chapter 8 "Access to Endpoint Buffers"*), most will use the FX2 simply as a conduit between the USB and external data-processing logic (e.g., an ASIC or DSP, or the IDE controller on a hard disk drive).

In devices with external data-processing logic, USB data flows between the host and that external logic — *usually without any participation by the FX2's CPU* — through the FX2's internal *endpoint FIFOs*. To the external logic, these endpoint FIFOs look like most others; they provide the usual timing signals, handshake lines (full, empty, programmable-level), read and write strobes, output enable, etc.

These FIFO signals must, of course, be controlled by a FIFO "master". The FX2's General Programmable Interface (GPIF) can act as an *internal* master when the FX2 is connected to external logic which doesn't include a standard FIFO interface, or the FIFOs can be controlled by an external master. While its FIFOs are controlled by an external master, the FX2 is said to be in "Slave FIFO" mode.

Chapter 10, "General Programmable Interface (GPIF)," discusses the internal-master GPIF. This chapter provides details on the interface — both hardware and software — between the FX2's slave FIFOs and an *external* master.

## 9.2 Hardware

Figure 9-1 illustrates the four slave FIFOs. The figure shows the FIFOs operating in 16-bit mode, although they can also be configured for 8-bit operation.

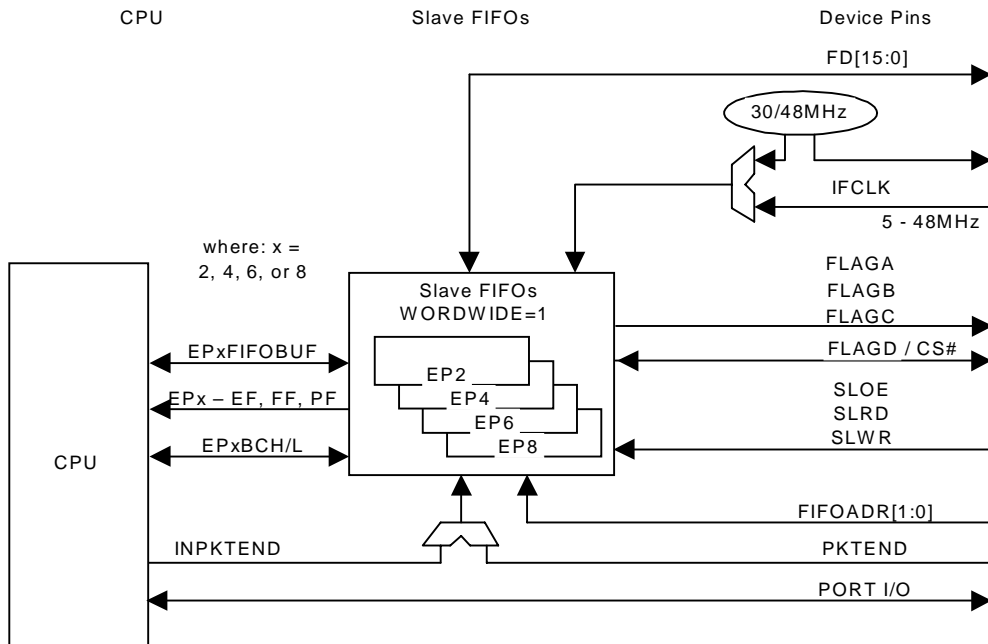

Figure 9-1. Slave FIFOs' Role in the FX2 System

Table 9-1 lists the registers associated with the slave-FIFO hardware. The registers are fully described in *Chapter 15, "Registers."*

Table 9-1. Registers Associated with Slave FIFO Hardware

IFCONFIG	EPxFIFOPFH/L
PINFLAGAB	PORTACFG
PINFLAGCD	INPKTEND
FIFORESET	EPxFLAGIE
FIFOPINPOLAR	EPxFLAGIRQ
EPxCFG	EPxFIFOBCH:L
EPxFIFOCFG	EPxFLAGS
EPxAUTOINLENH:L	EPxBUF

## 9.2.1 Slave FIFO Pins

The FX2 comes out of reset with its I/O pins configured in “Ports” mode, not “Slave FIFO” mode. To configure the pins for Slave FIFO mode, the IFCFG1:0 bits in the IFCONFIG register must be set to 11 (see Table 13-10, “IFCFG Selection of Port I/O Pin Functions” for details). When IFCFG1:0 = 11, the Slave FIFO interface pins are presented to the external master, as shown in Figure 9-2.

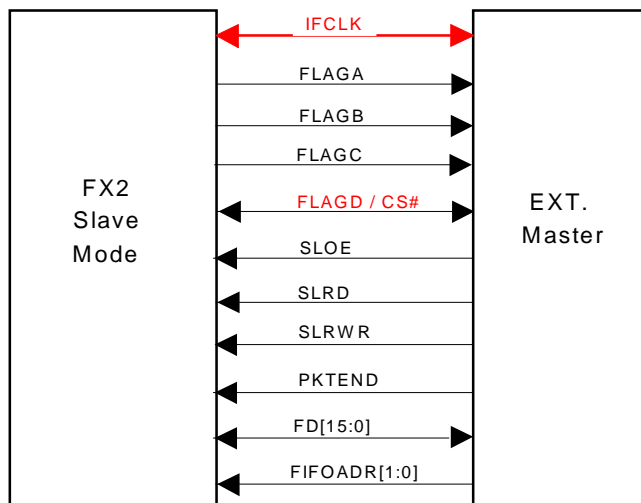

Figure 9-2. FX2 Slave Mode Full-Featured Interface Pins

External logic accesses the FIFOs through an 8- or 16-bit-wide data bus, FD. The data bus is bidirectional, with its output drivers controlled by the SLOE pin.

The FIFOADR[1:0] pins select which of the four FIFOs is connected to the FD bus.

In asynchronous mode (IFCONFIG.3 = 1), SLRD and SLWR are read and write strobes; in synchronous mode (IFCONFIG.3 = 0), SLRD and SLWR are enables for the IFCLK clock pin.

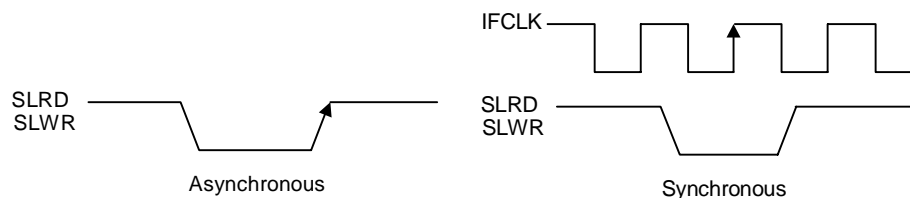

Figure 9-3. Asynchronous vs. Synchronous Timing Models

## 9.2.2 FIFO Data Bus (FD)

The FIFO data bus, FD[x:0], can be either 8 or 16 bits wide. The width is selected via each FIFO's WORDWIDE bit, (EPxFIFOCFG.0):

- WORDWIDE=0: 8-bit mode. FD[7:0] replaces Port B. See Figure 9-4.
- WORDWIDE=1: 16-bit mode. FD[15:8] replaces Port D and FD[7:0] replaces Port B. See Figure 9-5.

At power-on reset, the FIFO data bus defaults to 16-bit mode (WORDWIDE = 1) for all FIFOs.

In either mode, the FIFOADR[1:0] pins select which of the four FIFOs is internally connected to the FD pins.



*If **all** of the FIFOs are configured for 8-bit mode, Port D remains available for use as general-purpose I/O. If **any** FIFO is configured for 16-bit mode, Port D is unavailable for use as general-purpose I/O regardless of which FIFO is currently selected via the FIFOADR[1:0] pins.*

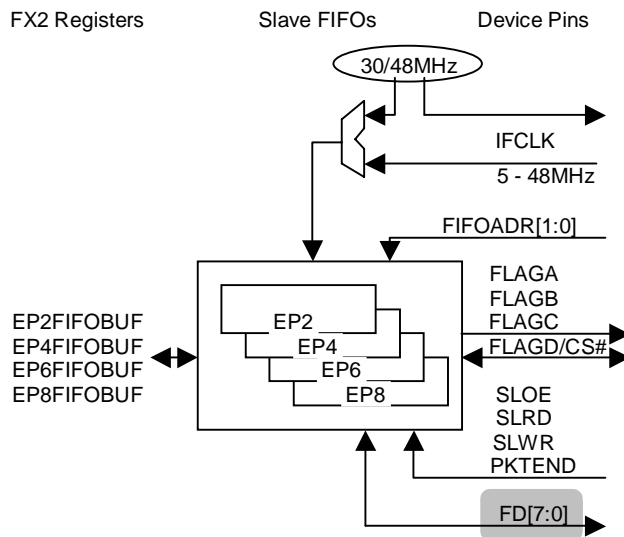

Figure 9-4. 8-bit Mode Slave FIFOs, WORDWIDE=0

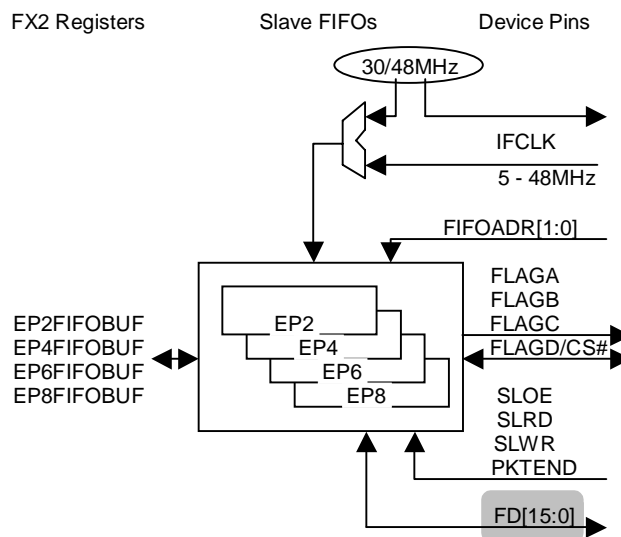

Figure 9-5. 16-bit Mode Slave FIFOs, WORDWIDE=1

### 9.2.3 Interface Clock (IFCLK)

The slave FIFO interface can be clocked from either an internal or an external source. The FX2's internal clock source can be configured to run at either 30 or 48 MHz, and it can optionally be output on the IFCLK pin. If the FX2 is configured to use an external clock source, the IFCLK pin can be driven at any frequency between 5 MHz and 48 MHz. On power-on reset, the FX2 defaults to the internal source at 48 MHz, normal polarity, with the IFCLK output disabled. See Figur e9-6.

IFCONFIG.7 selects between internal and external sources: 0 = external, 1 = internal.

IFCONFIG.6 selects between the 30- and 48-MHz internal clock: 0 = 30 MHz, 1 = 48 MHz. This bit has no effect when IFCONFIG.7 = 0.

IFCONFIG.5 is the output enable for the internal clock source: 0 = disable, 1 = enable. This bit has no effect when IFCONFIG.7 = 0.

IFCONFIG.4 inverts the polarity of the interface clock (whether it's internal or external): 0 = normal, 1 = inverted. IFCLK inversion can make it easier to interface the FX2 with certain external circuitry; Figure 9-7, for example, demonstrates the use of IFCLK inversion in order to ensure a long-enough setup time for reading the FX2's FIFO flags.



*When IFCLK is configured as an input, the minimum frequency that can be applied to it is 5 MHz.*

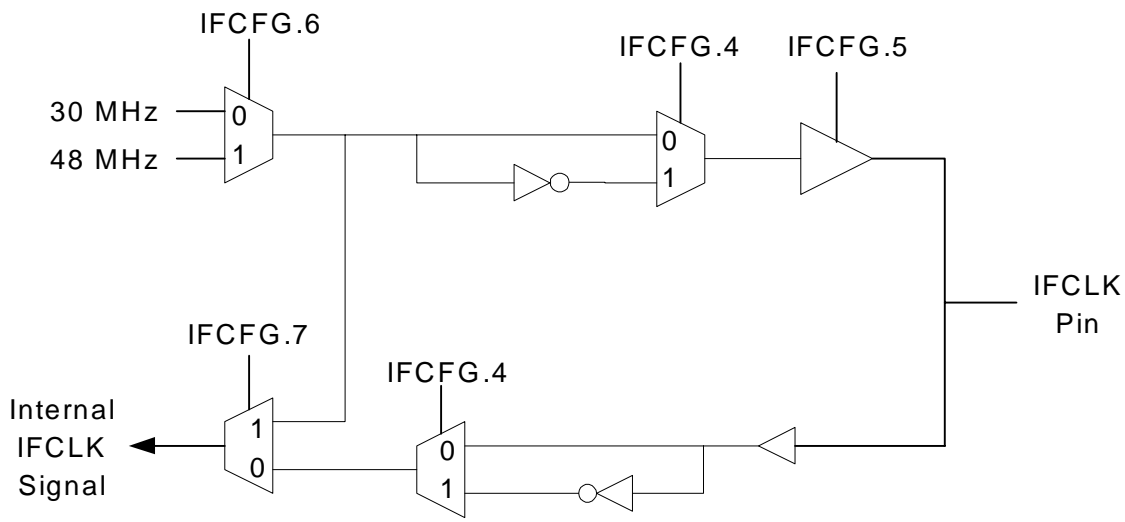

Figure 9-6. IFCLK Configuration

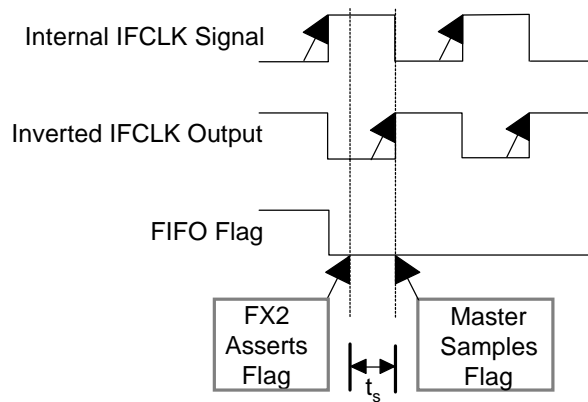

Figure 9-7. Satisfying Setup Timing by Inverting the IFCLK Output

### 9.2.4 FIFO Flag Pins (FLAGA, FLAGB, FLAGC, FLAGD)

Four pins — FLAGA, FLAGB, FLAGC, and FLAGD — report the status of the FX2's FIFOs; in addition to the usual "FIFO full" and "FIFO empty" signals, there is also a signal which indicates that a FIFO has filled to a user-programmable level. The external master typically monitors the "empty" flag of OUT endpoints and the "full" flag of IN endpoints; the "programmable-level" flag is



equally useful for either type of endpoint (it can, for instance, give advance warning that an OUT endpoint is almost empty or that an IN endpoint is almost full).

The FLAGA, FLAGB, and FLAGC pins can operate in either of two modes: *Indexed* or *Fixed*, as selected via the PINFLAGSAB and PINFLAGSCD registers. The FLAGD pin operates in Fixed mode only. Each pin is configured independently; some pins can be in Fixed mode while others are in Indexed mode. See Chapter 15, "Registers," for complete details.

Flag pins configured for Indexed mode report the status of the FIFO currently selected by the FIFOADR[1:0] pins. When configured for Indexed mode, FLAGA reports the "programmable-level" status, FLAGB reports the "full" status, and FLAGC reports the "empty" status.

Flag pins configured for Fixed mode report one of the three conditions for a specific FIFO, regardless of the state of the FIFOADR[1:0] pins. The condition and FIFO are user-selectable. For example, FLAGA could be configured to report FIFO2's "empty" status, FLAGB to report FIFO4's "empty" status, FLAGC to report FIFO4's "programmable level" status, and FLAGD to report FIFO6's "full" status.

The polarity of the "empty" and "full" flag pins defaults to active-low but may be inverted via the FIFOPINPOLAR register.

At power-on reset, the FIFO flags are configured for Indexed operation.

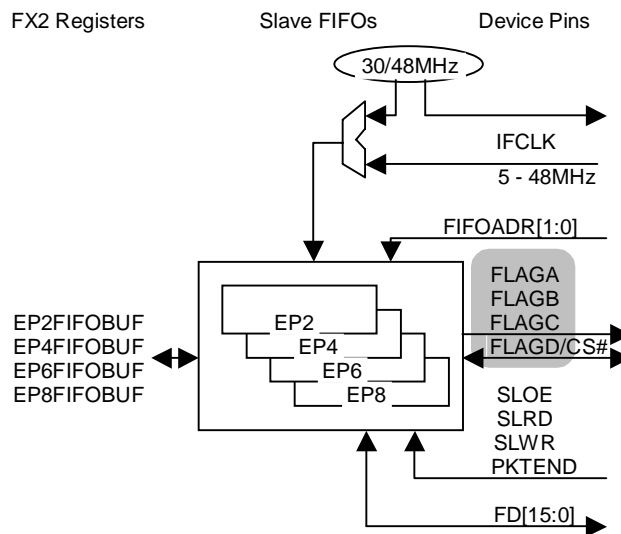

Figure 9-8. FLAGx Role

## 9.2.5 Control Pins (SLOE, SLRD, SLWR, PKTEND, FIFOADR[1:0])

The Slave FIFO “control” pins are SLOE (Output Enable), SLRD (Read), SLWR (Write), PKTEND (Packet End), and FIFOADR[1:0] (FIFO Select). “Read” and “Write” are from the external master’s point of view; the external master reads from OUT endpoints and writes to IN endpoints. See Figure 9-9.

### Read — SLOE and SLRD:

In synchronous mode (IFCONFIG.3 = 0), the FIFO pointer is incremented on each rising edge of IFCLK while SLRD is asserted. In asynchronous mode (IFCONFIG.3 = 1), the FIFO pointer is incremented on each asserted-to-deasserted transition of SLRD.

The SLOE pin enables the FD outputs.

By default, SLOE and SLRD are active-low; their polarities can be changed via the FIFOPINPOLAR register.

### Write — SLWR:

In synchronous mode (IFCONFIG.3 = 0), data on the FD bus is written to the FIFO (and the FIFO pointer is incremented) on each rising edge of IFCLK while SLWR is asserted. In asynchronous mode (IFCONFIG.3 = 1), data on the FD bus is written to the FIFO (and the FIFO pointer is incremented) on each asserted-to-deasserted transition of SLWR.

By default, SLWR is active-low; its polarity can be changed via the FIFOPINPOLAR register.

### FIFOADR[1:0]:

The FIFOADR[1:0] pins select which of the four FIFOs is connected to the FD bus (and, if the FIFO flags are operating in Indexed mode, they select which FIFO’s flags are presented on the FLAGx pins):

Table 9-2. FIFO Selection via FIFOADR[1:0]

FIFOADR[1:0]	Selected FIFO
00	EP2
01	EP4
10	EP6
11	EP8

## PKTEND:

An external master asserts the PKTEND pin to commit an IN packet to USB regardless of the packet's length. PKTEND is usually used when the master wishes to send a "short" packet (i.e., a packet smaller than the size specified in the EPxAUTOINLENH:L registers).

For example: Assume that EP4AUTOINLENH:L is set to the default of 512 bytes. If AUTOIN = 1, the external master can stream data to FIFO4 continuously, and (absent any bottlenecks in the data path) the FX2 will automatically commit a packet to USB whenever the FIFO fills with 512 bytes. If the master wants to send a stream of data whose length is not a multiple of 512, the last packet will *not* be automatically committed to USB because it's smaller than 512 bytes. To commit that last packet, the master can do one of two things: It can pad the packet with dummy data in order to make it exactly 512 bytes long, or it can write the short packet to the FIFO then assert the PKTEND pin.

If the FIFO is configured to allow zero-length packets (EPxFIFOCFG.2 = 1), asserting the PKTEND pin when the FIFO is empty will commit a zero-length packet.

By default, PKTEND is active-low; its polarity can be changed via the FIFOPINPOLAR register.



*The PKTEND pin must not be asserted unless a buffer is available, even if only a zero-length packet is being committed. The "full" flag may be used to determine whether a buffer is available.*

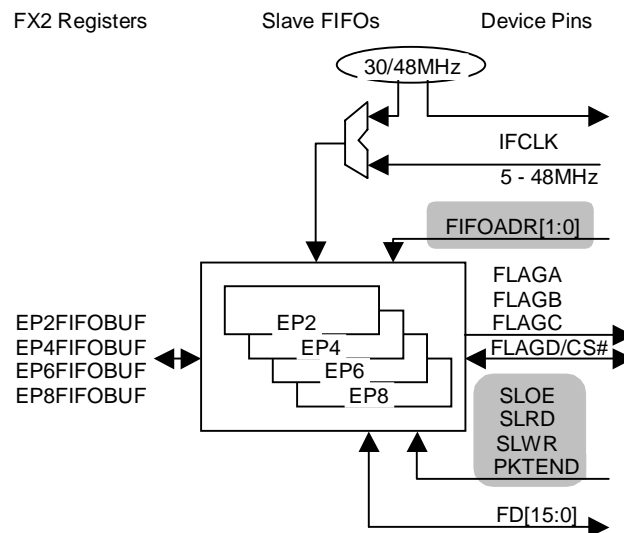

Figure 9-9. Slave FIFO Control Pins

## 9.2.6 Slave FIFO Chip Select ( $\overline{\text{SLCS}}$ )

The “Slave FIFO Chip Select” pin ( $\overline{\text{SLCS}}$ ) is an alternate function of pin PA7; it’s enabled via the PORTACFG.6 bit (see Section 13.3.1, “Port A Alternate Functions”).

The  $\overline{\text{SLCS}}$  pin allows external logic to effectively remove the FX2 from the FIFO Data bus, in order to, for example, share that bus among multiple slave devices.

While the  $\overline{\text{SLCS}}$  pin is pulled low by external logic, the FX2 floats its FD[x:0] pins and ignores the SLOE, SLRD, SLWR, and PKTEND pins.

## 9.2.7 Implementing Synchronous Slave FIFO Writes

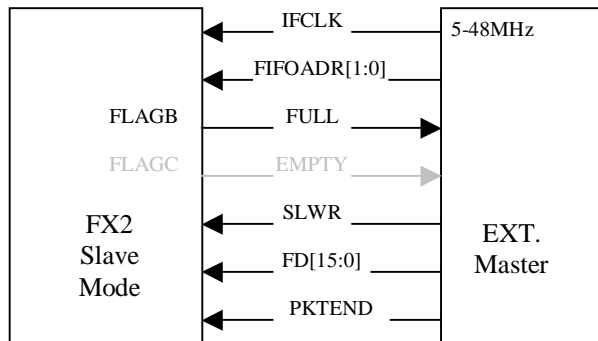

Figure 9-10. Interface Pins Example: Synchronous FIFO Writes

Typically, the sequence of events for the external master is:

IDLE: When write event occurs, transition to State 1.

STATE 1: Point to IN FIFO, assert FIFOADR[1:0], transition to State 2.

STATE 2: If FIFO-Full flag is false (FIFO not full), transition to State 3 else remain in State 2.

STATE 3: Drive data on the bus, assert SLWR for one IFCLK, transition to State 4.

STATE 4: If more data to write, transition to State 2 else transition to IDLE.

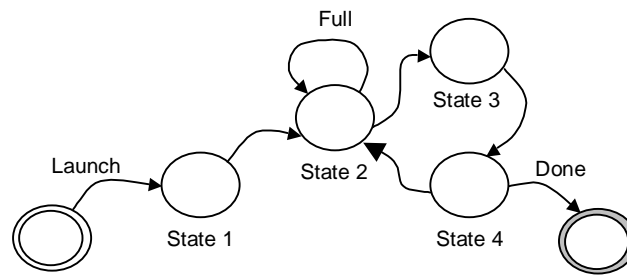

Figure 9-11. State Machine Example: Synchronous FIFO Writes

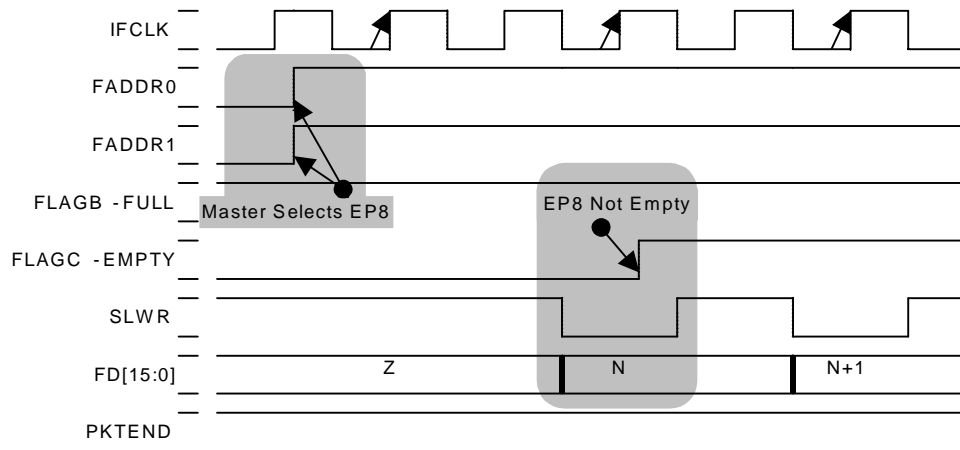

Figure 9-12. Timing Example: Synchronous FIFO Writes, Waveform 1

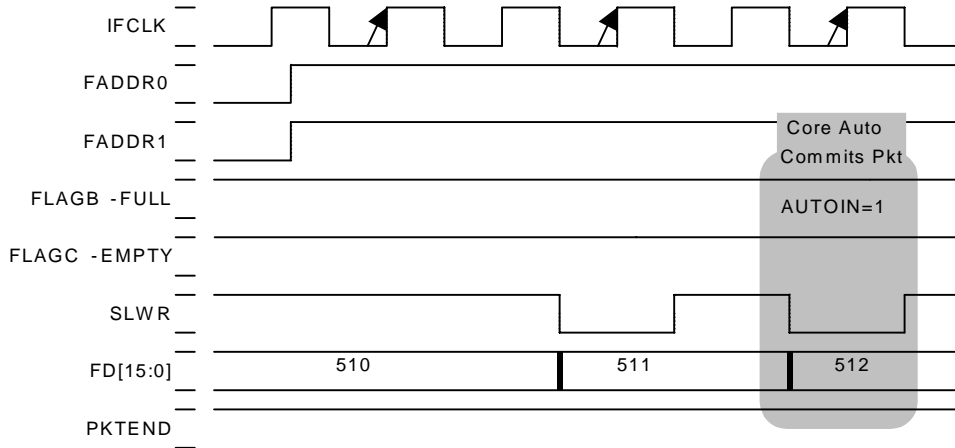

Figure 9-13. Timing Example: Synchronous FIFO Writes, Waveform 2

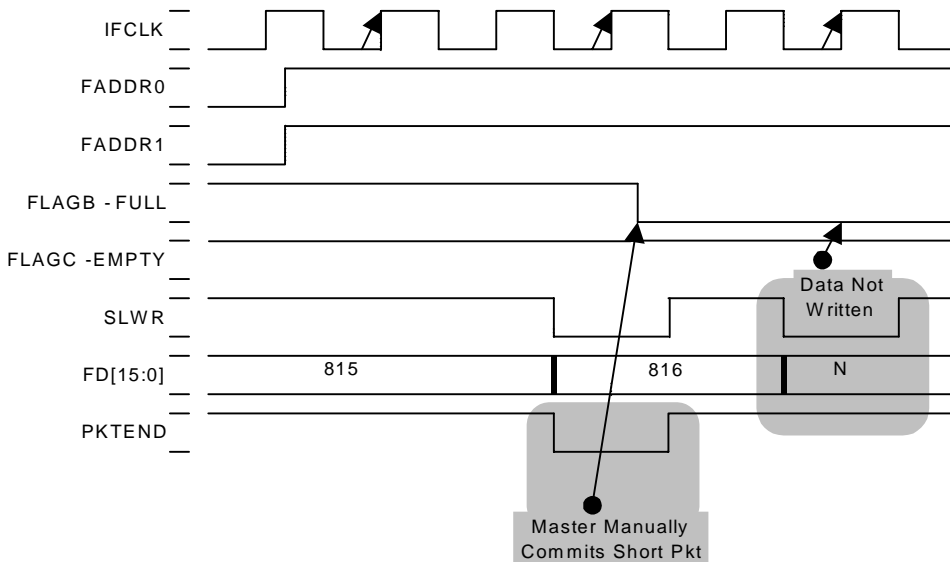

Figure 9-14. Timing Example: Synchronous FIFO Writes, Waveform 3, PKTEND Pin Illustrated

## 9.2.8 Implementing Synchronous Slave FIFO Reads

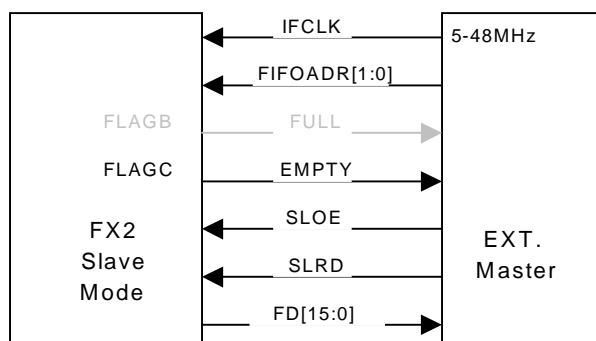

Figure 9-15. Interface Pins Example: Synchronous FIFO Reads

Typically, the sequence of events for the external master is:

IDLE: When read event occurs, transition to State 1.

STATE 1: Point to OUT FIFO, assert FIFOADR[1:0], transition to State 2.

STATE 2: Assert SLOE. If FIFO-Empty flag is false (FIFO not empty), transition to State 3 else remain in State 2.

STATE 3: Sample data on the bus, increment pointer by asserting SLRD for one IFCLK, de-assert SLOE, transition to State 4.

STATE 4: If more data to read, transition to State 2 else transition to IDLE.

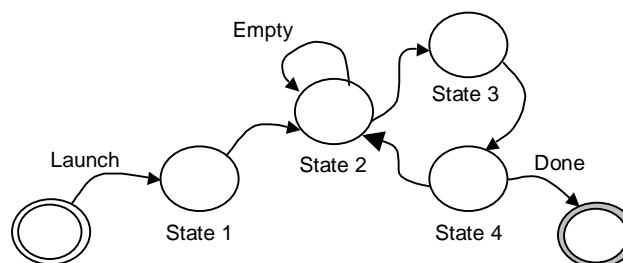

Figure 9-16. State Machine Example: Synchronous FIFO Reads

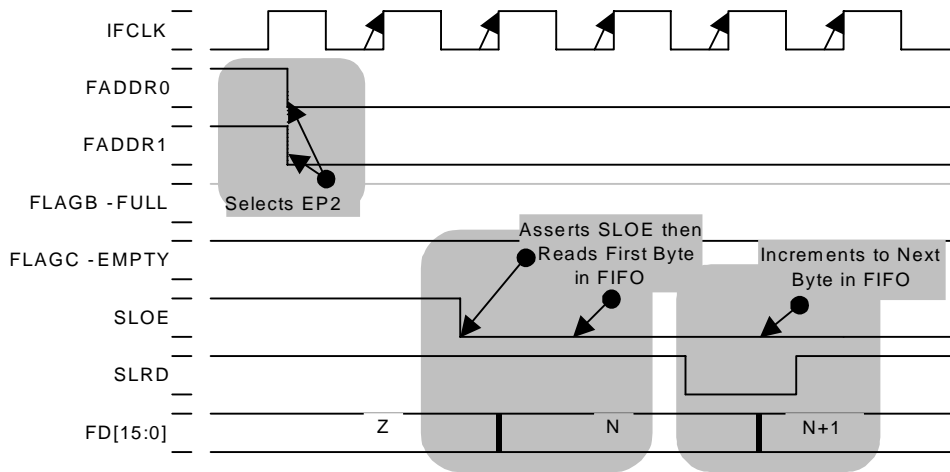

Figure 9-17. Timing Example: Synchronous FIFO Reads, Waveform 1

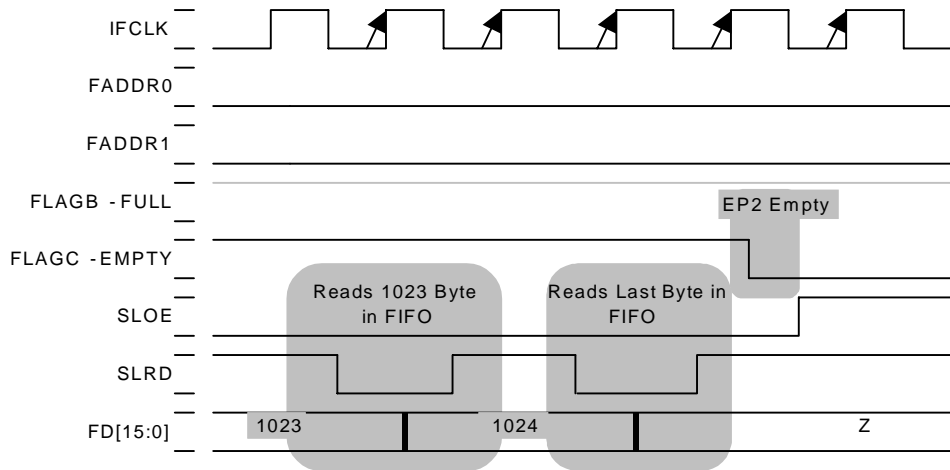

Figure 9-18. Timing Example: Synchronous FIFO Reads, Waveform 2, EMPTY Flag Illustrated



## 9.2.9 Implementing Asynchronous Slave FIFO Writes

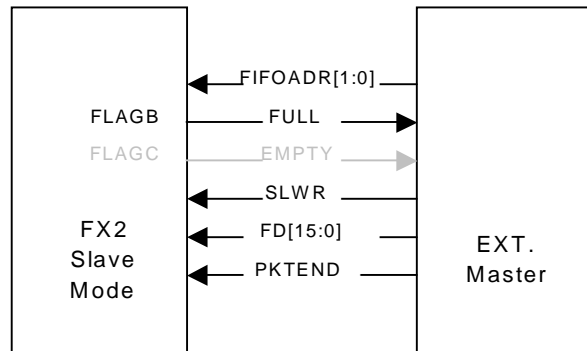

Figure 9-19. Interface Pins Example: Asynchronous FIFO Writes

Typically, the sequence of events for the external master is:

IDLE: When write event occurs, transition to State 1.

STATE 1: Point to IN FIFO, assert FIFOADR[1:0], transition to State 2.

STATE 2: If FIFO-Full flag is false (FIFO not full), transition to State 3 else remain in State 2.

STATE 3: Drive data on the bus, increment pointer by asserting then de-asserting SLWR, transition to State 4.

STATE 4: If more data to write, transition to State 2 else transition to IDLE.

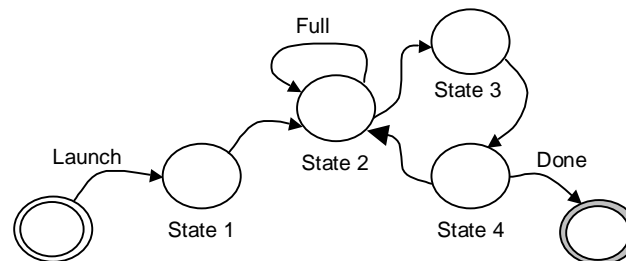

Figure 9-20. State Machine Example: Asynchronous FIFO Writes

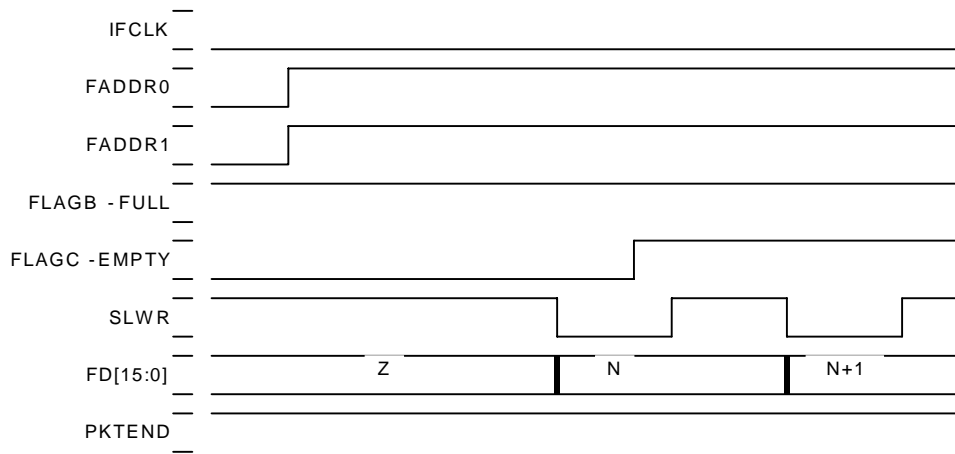

Figure 9-21. Timing Example: Asynchronous FIFO Writes

## 9.2.10 Implementing Asynchronous Slave FIFO Reads

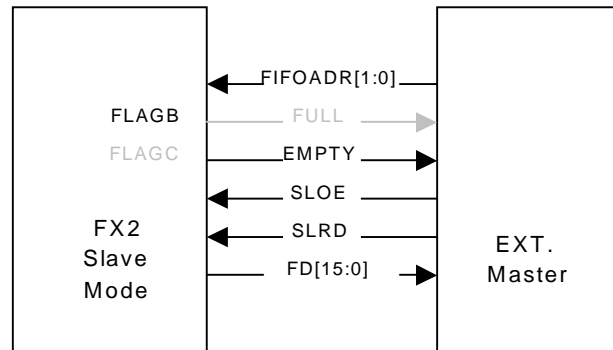

Figure 9-22. Interface Pins Example: Asynchronous FIFO Reads

Typically, the sequence of events for the external master is:

IDLE: When read event occurs, transition to State 1.

STATE 1: Point to OUT FIFO, assert FIFOADR[1:0], transition to State 2.

STATE 2: If Empty flag is false (FIFO not empty), transition to State 3 else remain in State 2.

STATE 3: Assert SLOE, assert SLRD, sample data on the bus, de-assert SLRD (increment pointer), de-assert SLOE, transition to State 4.

STATE 4: If more data to read, transition to State 2 else transition to IDLE.

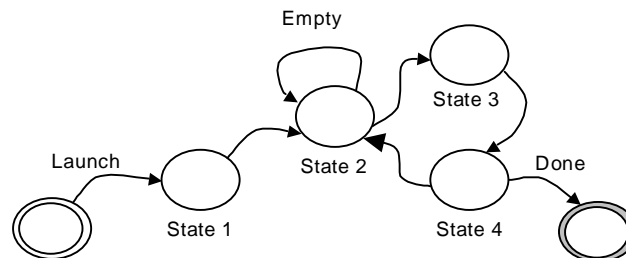

Figure 9-23. State Machine Example: Asynchronous FIFO Reads

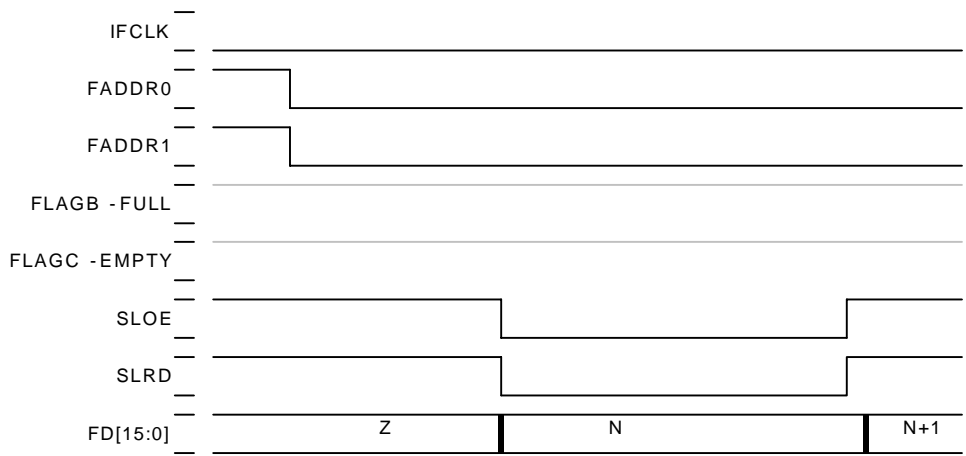

Figure 9-24. Timing Example: Asynchronous FIFO Reads

## 9.3 Firmware

This section describes the interface between FX2 firmware and the FIFOs. More information is available in *Chapter 8, "Access to Endpoint Buffers."*

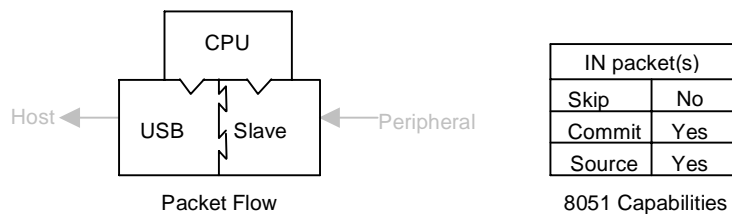

Figure 9-25. Firmware Access to IN Data

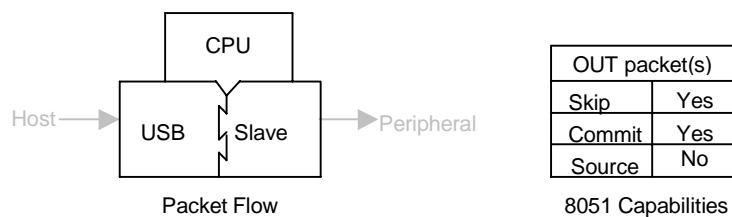

Figure 9-26. Firmware Access to OUT Data

Table 9-3. Registers Associated with Slave FIFO Firmware

EPxCFG	INPKTEND
EPxFIFO CFG	EPxFIFOIE
EPxAUTOINLENH/L	EPxFIFOIRQ
EPxFIFOPFH/L	INT2IVEC
EP2468STAT	INT4IVEC
EP24FIFOFLGS	INTSETUP
EP68FIFOFLGS	IE
EPxCS	IP
EPxFIFOFLGS	INT2CLR
EPxBCH/L	INT4CLR
EPxFIFOBCH/L	EIE
EPxFIFOBUF	EXIF

### 9.3.1 Firmware FIFO Access

FX2 firmware can access the slave FIFOs using four registers in XDATA memory: EP2FIFOBUF, EP4FIFOBUF, EP6FIFOBUF, and EP8FIFOBUF. These registers can be read and written directly (using the MOVX instruction), or they can serve as sources and destinations for the dual Auto-pointer mechanism built into the EZ-USB FX2 (see Section 8.8. "Autopointers").

Additionally, there are a number of FIFO control and status registers: Byte Count registers indicate the number of bytes in each FIFO; flag bits indicate FIFO fullness, mode bits control the various FIFO modes, etc.

This chapter focuses on the registers and bits which are specific to slave-FIFO operation; for a fuller description of all the FIFO registers, see *Chapter 8 "Access to Endpoint Buffers"* and *Chapter 15, "Registers."*

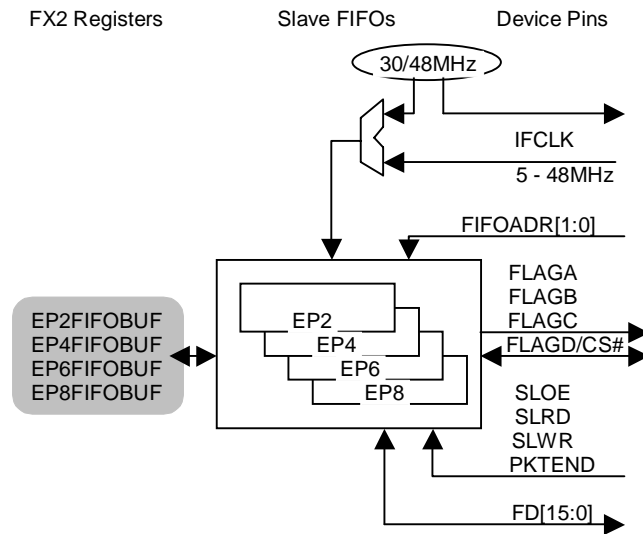

Figure 9-27. EPxFIFOBUF Registers

### 9.3.2 EPx Memories

The slave FIFOs connect external logic to the FX2's four endpoint memories (EP2, EP4, EP6, and EP8). These endpoint memories have the following programmable features:

1. Type can be either BULK, INTERRUPT, or ISOCHRONOUS.
2. Direction can be either IN or OUT.

3. For EP2 and EP6, size can be either 512 or 1024 bytes. EP4 and EP8 are fixed at 512 bytes.
4. Buffering can be 2x, 3x, or 4x for EP2 and EP6. EP4 and EP8 are fixed at 2x.
5. FX2 automatically commits endpoint data to and from the slave FIFO interface (AUTOIN=1, AUTOOUT=1).

At power-on-reset, these endpoint memories are configured as follows:

1. EP2 - Bulk OUT, 512 bytes/packet, 2x buffered.
2. EP4 - Bulk OUT, 512 bytes/packet, 2x buffered.
3. EP6 - Bulk IN, 512 bytes/packet, 2x buffered.
4. EP8 - Bulk IN, 512 bytes/packet, 2x buffered.

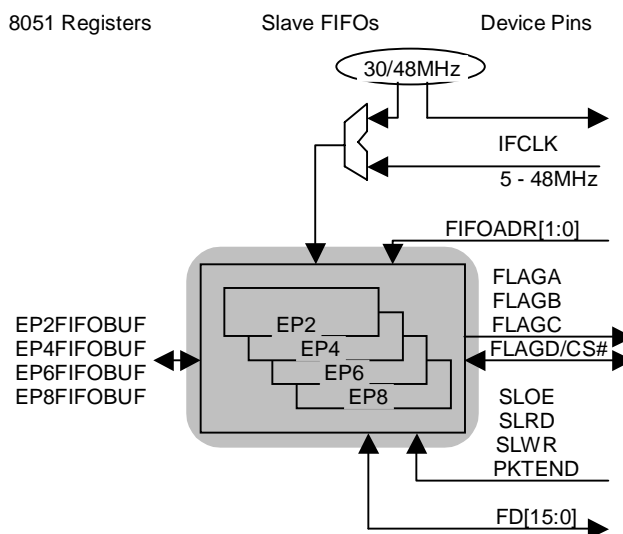

Figure 9-28. EPx Memories

### 9.3.3 Slave FIFO Programmable-Level Flag (PF)

Each FIFO's programmable-level flag (PF) asserts when the FIFO reaches a user-defined fullness threshold. That threshold is configured as follows:

1. For OUT packets: The threshold is stored in PFC12:0. The PF is asserted when the number of bytes *in the entire FIFO* is less than/equal to (DECIS=0) or greater than/equal to (DECIS=1) the threshold.
2. For IN packets, with PKTSTAT = 1: The threshold is stored in PFC9:0. The PF is asserted when the number of bytes written into *the current packet in the FIFO* is less than/equal to (DECIS=0) or greater than/equal to (DECIS=1) the threshold.
3. For IN packets, with PKTSTAT = 0: The threshold is stored in two parts: PKTS2:0 holds the number of committed packets, and PFC9:0 holds the number of bytes in the current packet.

The PF is asserted when the FIFO is at or less full than (DECIS=0), or at or more full than (DECIS=1), the threshold.

By default, FLAGA is the Programmable-Level Flag (PF) for the endpoint currently pointed to by the FIFOADR[1:0] pins. For EP2 and EP4, the default endpoint configuration is BULK, OUT, 512, 2x, and the PF pin asserts when the entire FIFO has greater than/equal to 512 bytes. For EP6 and EP8, the default endpoint configuration is BULK, IN, 512, 2x, and the PF pin asserts when the entire FIFO has less than/equal to 512 bytes.

In other words, the default-configuration PFs for EP2 and EP4 assert when the FIFOs are half-full, and the default-configuration PFs for EP6 and EP8 assert when those FIFOs are half-empty.

See Chapter 15, "Registers," for full details.

### 9.3.4 Auto-In / Auto-Out Modes

The FX2 FIFOs can be configured to commit packets to/from USB automatically. For IN endpoints, Auto-In Mode allows the external logic to stream data into a FIFO continuously, with no need for it or the FX2 firmware to packetize the data or explicitly signal the FX2 to send it to the host. For OUT endpoints, Auto-Out Mode allows the host to continuously fill a FIFO, with no need for the external logic or FX2 firmware to handshake each incoming packet, arm the endpoint buffers, etc. See Figure 9-29.

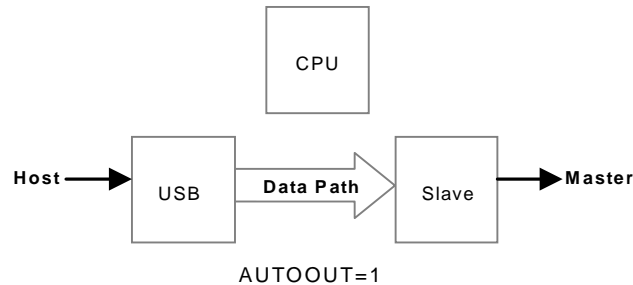

Figure 9-29. When AUTOOUT=1, OUT Packets are Automatically Committed

To configure an IN endpoint FIFO for Auto Mode, set the AUTOIN bit in the appropriate EPxFIFOCFG register to 1. To configure an OUT endpoint FIFO for Auto Mode, set the AUTOOUT bit in the appropriate EPxFIFOCFG register to 1. See Figures 9-30 and 9-31.

At power-on reset, all FIFOs default to Manual Mode (i.e., AUTOIN = 0 and AUTOOUT = 0).

```

TD_Init():
... ..
EP2CFG = 0xA2; // EP2 is DIR=OUT, TYPE=BULK, SIZE=512, BUF=2x
EP2FIFOCFG = 0x10; // EP2 is AUTOOUT=1, AUTOIN=0, ZEROLEN=0, WORDWIDE=0
// "all" EP2 buffers automatically arm when AUTOOUT=1
... ..

```

Figure 9-30. TD\_Init Example: Configuring AUTOOUT = 1



```
TD_Init():
... ..
EP8CFG = 0xE0; // EP8 is DIR=IN, TYPE=BULK
EP8FIFOCFG = 0x0C; // EP8 is AUTOOUT=0, AUTOIN=1, ZEROLEN=1, WORDWIDE=0
EP8AUTOINLENH = 0x02; // if AUTOIN=1, auto commit 512 byte packets
EP8AUTOINLENL = 0x00;
... ..
```

Figure 9-31. TD\_Init Example: Configuring AUTOIN = 1

### 9.3.5 CPU Access to OUT Packets, AUTOOUT = 1

The FX2's CPU is not in the host-to-master data path when AUTOOUT = 1. To achieve the maximum USB 2.0 bandwidth, the host and master are directly connected, bypassing the CPU. Figure 9-32 shows that, in Auto-Out mode, data from the host is automatically committed to the FIFOs with no firmware intervention.

```
TD_Poll():
... ..
// no code necessary to xfr data from host to master!
// AUTOOUT=1 and SIZE=0 auto-commits packets
// in 512 byte chunks.
... ..
```

Figure 9-32. TD\_Poll Example: No Code Necessary for OUT Packets When AUTOOUT=1

### 9.3.6 CPU Access to OUT Packets, AUTOOUT = 0

In some systems, it may be desirable to allow the FX2's CPU to participate in the transfer of data between the host and the slave FIFOs. To configure a FIFO for this "Manual-Out" mode, the AUTOOUT bit in the appropriate EPxFIFOCFG register must be cleared to 0 (see Figure 9-33).

```
TD_Init():
... ..
EP2CFG = 0xA2; // EP2 is DIR=OUT, TYPE=BULK, SIZE=512, BUF=2x
EP2FIFOCFG = 0x00; // EP2 is AUTOOUT=0, AUTOIN=0, ZEROLEN=0, WORDWIDE=0
// OUT endpoints do NOT come up armed
EP2BCL = 0x80; // arm first buffer by writing BC w/skip=1
EP2BCL = 0x80; // arm second buffer by writing BC w/skip=1
... ..
```

Figure 9-33. TD\_Init Example, AUTOOUT=0

As illustrated in Figure 9-34, FX2 firmware can do one of two things when it's in Manual-Out mode and a packet is received from the host:

1. It can *commit* (pass to the FIFOs) the packet by writing EPxBCL with SKIP=0 (Figure 9-35).
2. It can *skip* (discard) the packet by writing EPxBCL with SKIP=1 (Figure 9-36).

In either case, the OUT buffer automatically re-arms so it can receive the next packet.

See Section 8.6.2.4 for a detailed description of the SKIP bit.

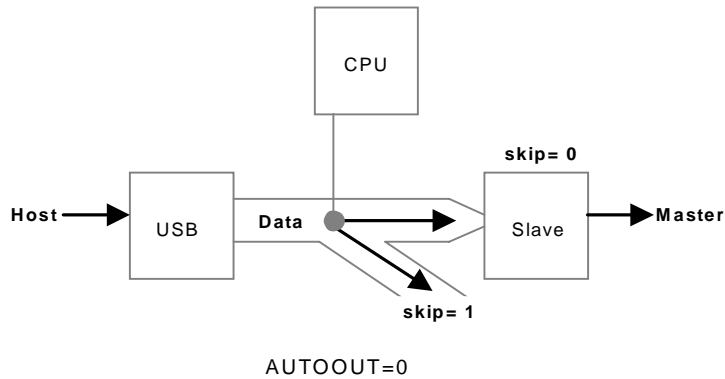

Figure 9-34. Skip or Commit, AUTOOUT=0

```

TD_Poll():
... ..
if( !( EP2468STAT & 0x01 ) )
{ // EP2EF=0 when FIFO NOT empty, host sent packet
  EP2BCL = 0x00; // SKIP=0, pass buffer on to master
}
... ..
    
```

Figure 9-35. TD\_Poll Example, AUTOOUT=0, Commit Packet

```

TD_Poll():
... ..
if( !( EP2468STAT & 0x01 ) )
{ // EP2EF=0 when FIFO NOT empty, host sent packet
  EP2BCL = 0x80; // SKIP=1, do NOT pass buffer on to master
}
... ..
    
```

Figure 9-36. TD\_Poll Example, AUTOOUT=0, Skip Packet

FX2 firmware does not have the ability to change the length of an OUT packet, but (as shown in Figure 9-37), it *can* modify the contents of an OUT packet before choosing to commit or discard it.



*Firmware can not source (i.e., directly create by writing to the EPx memories) an OUT packet.*

```

TD_Poll():
... ..
if( !( EP2468STAT & 0x01 ) )
{ // EP2EF=0 when FIFO NOT empty, host sent packet
  // modify the data
  EP2FIFOBUF[ 0 ] = 0x02; // <STX>, packet start of text msg
  EP2FIFOBUF[ 9 ] = 0x03; // <ETX>, packet end of text msg
  if( my_foo_pkt_good( EP2FIFOBUF ) )
  {
    EP2BCL = 0x00; // SKIP=0, pass buffer on to master
  }
  else
  {
    EP2BCL = 0x80; // SKIP=1, do NOT pass buffer on to master
  }
}
... ..

```

Figure 9-37. TD\_Poll Example, AUTOOUT=0, Commit or Skip



*If an uncommitted packet is in an OUT endpoint buffer when the FX2 is reset, that packet is **not** automatically committed to the host. To ensure that no uncommitted packets are in the endpoint buffers after a reset, the FX2 firmware's "endpoint initialization" routine should skip 2, 3, or 4 packets (depending on the buffering depth selected for the FIFO) by writing EPxBCL with SKIP=1. See Figure 9-38.*

```

TD_Init():
... ..
EP2CFG = 0xA2; // EP2 is DIR=OUT, TYPE=BULK, SIZE=512, BUF=2x
EP2FIFOCFG = 0x00; // EP2 is AUTOOUT=0, AUTOIN=0, ZEROLEN=0, WORDWIDE=0
// OUT endpoints do NOT come up armed
EP2BCL = 0x80; // arm first buffer by writing BC w/skip=1
EP2BCL = 0x80; // arm second buffer by writing BC w/skip=1
... ..

```

Figure 9-38. TD\_Init Example, OUT Endpoint Initialization

### 9.3.7 CPU Access to IN Packets, AUTOIN = 1

Auto-In mode is similar to Auto-Out mode: When an IN FIFO is configured for Auto-In mode (by setting its AUTOIN bit to 1), data from the master is automatically packetized and committed to USB without any CPU intervention (see Figure 9-39).

```

TD_Poll():
... ..
// no code necessary to xfr data from master to host!
// AUTOIN=1 and EP8AUTOINLEN=512 auto commits packets
// in 512 byte chunks.
... ..

```

Figure 9-39. TD\_Poll Example, AUTOIN = 1

Auto-In mode differs in two important ways from Auto-Out mode:

1. In Auto-Out mode, data (excluding data in short packets) is always auto-committed in 512- or 1024-byte packets; in Auto-In mode, the auto-commit packet size may be set to *any non-zero value* (with the single restriction, of course, that the packet size must be less than or equal to the size of the endpoint buffer). Each FIFO's Auto-In packet size is stored in its EPxAUTOINLENH:L register pair.
2. In Auto-In mode, the CPU can *source* IN packets. In other words, FX2 firmware can temporarily halt the flow of data from the external master (via a signal on a general-purpose I/O pin, typically), wait for an endpoint buffer to become available, create a new packet by writing directly to that buffer, then commit the packet to USB and release the external master. In this way, the firmware can insert its own packets in the data stream. See Figure 9-40, which illustrates data flowing directly between the master and the host, and Figure 9-41, which shows the CPU sourcing an IN packet. A firmware example appears in Figure 9-42.

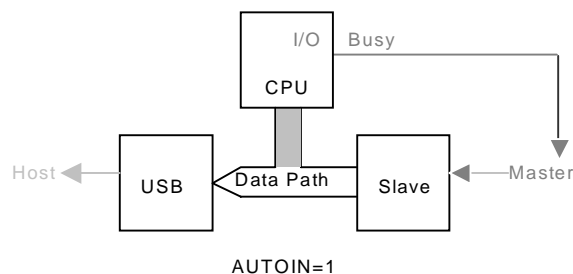

Figure 9-40. Master Writes Directly to Host, AUTOIN = 1

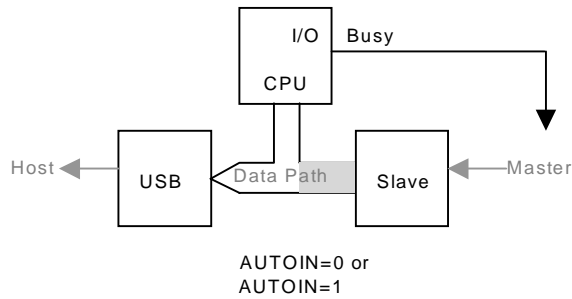

Figure 9-41. Firmware Intervention, AUTOIN = 0 or 1

```

TD_Poll():
... ..
if( source_pkt_event )
{ // 100-msec background timer fired
  if( holdoff_master( ) )
  { // signaled "busy" to master successful
    while( !( EP68FIFOFLGS & 0x20 ) )
    { // EP8EF=0, when buffer not empty
      ; // wait 'til host takes entire FIFO data
    }

    FIFORESET = 0x80; // initiate the "source packet" sequence
    FIFORESET = 0x06;
    FIFORESET = 0x00;

    EP8FIFOBUF[ 0 ] = 0x02; // <STX>, packet start of text msg
    EP8FIFOBUF[ 1 ] = 0x06; // <ACK>
    EP8FIFOBUF[ 2 ] = 0x07; // <HEARTBEAT>
    EP8FIFOBUF[ 3 ] = 0x03; // <ETX>, packet end of text msg

    EP8BCH = 0x00;
    EP8BCL = 0x04; // pass newly-sourced buffer on to host
  }
  else
  {
    history_record( EP8, BAD_MASTER );
  }
}
... ..

```

Figure 9-42. TD\_Poll Example: Sourcing a Packet

### 9.3.8 Access to IN Packets, AUTOIN=0

In some systems, it may be desirable to allow the FX2's CPU to participate in every data-transfer between the external master and the host. To configure a FIFO for this "Manual-In" mode, the AUTOIN bit in the appropriate EPxFIFOCFG register must be cleared to 0.

In Manual-In mode, FX2 firmware *must* commit (pass to the USB) packets sent by the external master. It can, however, change the length and/or contents of the packet before committing it.

The firmware may commit the packet by either of two methods:

1. Writing the endpoint number (2, 4, 6, or 8) to the INPKTEND register (Figure 9-43).
2. Writing the packet length to the EPxBCH:L register pair (Figure 9-44).

The first method may only be used if the packet length and contents are not changed by the firmware; if the length or contents *are* changed, the "new" packet must be committed via the second method.

```

TD_Poll():
... ..
if( master_finished_longxfr( ) )
{ // master currently points to EP8, pins FIFOADR[1:0]=11
  if( !( EP68FIFOFLGS & 0x10 ) )
  { // EP8FF=0 when buffer available
    INPKTEND = 0x08; // firmware commits EP8 packet
                  // by writing 8 to INPKTEND
    release_master( EP8 );
  }
}
... ..

```

Figure 9-43. TD\_Poll Example, AUTOIN=0, Committing a Packet via INPKTEND

```
TD_Poll():
... ..
if( master_finished_xfr( ) )
{ // modify the data
  EP8FIFOBUF[ 0 ] = 0x02; // <STX>, packet start of text msg
  EP8FIFOBUF[ 7 ] = 0x03; // <ETX>, packet end of text msg
  EP8BCH = 0x00;
  EP8BCL = 0x08; // pass buffer on to host
}
... ..
```

Figure 9-44. TD\_Poll Example, AUTOIN=0, Committing a Packet via EPxBCH:L

### 9.3.9 Auto-In / Auto-Out Initialization

#### ***Enabling Auto-In transfers between slave FIFO and endpoint***

Typically, a FIFO is configured for Auto-In mode as follows:

1. Configure bits IFCONFIG[7:4] to define the behavior of the interface clock.
2. Set bits IFCFG1:0=11.
3. Set bit EPxFIFOCFG.3=1.
4. If an auto-commit packet size other than the default of 512 bytes is required, set the size via the EPxAUTOINLENH:L registers.

#### ***Enabling Auto-Out transfers between endpoint and slave FIFO***

Typically, a FIFO is configured for Auto-Out mode as follows:

1. Configure bits IFCONFIG[7:4] to define the behavior of the interface clock.
2. Set bits IFCFG1:0=11.
3. Set bit EPxFIFOCFG.4=1.

### 9.3.10 Auto-Mode Example: Synchronous FIFO IN Data Transfers

```

TD_Init():
FIFORESET = 0x80; // reset all FIFOs
FIFORESET = 0x02;
FIFORESET = 0x04;
FIFORESET = 0x06;
FIFORESET = 0x08;
FIFORESET = 0x00;
IFCONFIG = 0x43;
// this defines the external interface to be the following:
// use IFCLK pin driven by external logic (5MHz to 48MHz)
// use slave FIFO interface pins driven sync by external master

// EP8 (IN) is a good choice
EP8FIFCFG = 0x0C;
// this lets the FX2 auto commit IN packets, AUTOIN=1
// and gives the ability to send zero length packets, ZEROLENIN=1
// and sets the slave FIFO data interface to 8-bits
EP8CFG = 0xE0;
// sets EP8 valid for IN's
// and defines the endpoint for 512 byte packets, 2x buffered

FLAGSAB = 0x00;
FLAGSCD = 0x00;
// defines FLAGA as programmable flag, as pointed to by FIFOADR[1:0]
// FLAGB as full flag, as pointed to by FIFOADR[1:0]
// FLAGC as empty flag, as pointed to by FIFOADR[1:0]
// won't generally need FLAGD

PORTACFG = 0x00;
// used PA7/FLAGD as a port pin, not as a FIFO flag

FIFOPOLAR = 0x00;
// set all slave FIFO interface pins as active low

EP8PKTLENH = 0x02;
EP8PKTLENL = 0x00;
// you can define these as you wish to have the FX2 automatically limit IN's

EP8PFTH = 0x82;
EP8PFTL = 0x00;
// you can define the programmable flag (FLAGA) to be active at the level you wish

// out endpoints do not POR (power-on reset) armed
// since the defaults are double buffered we must
// write dummy byte counts twice
EP2BCL = EP4BCL = 0x80;
// arm EP2OUT & EP4OUT by writing to the byte count w/skip.
EP2BCL = EP4BCL = 0x80;
// arm EP2OUT & EP4OUT by writing to the byte count w/skip.

```

```

TD_Poll():
// nothing! The FX2 is doing all the work of transferring packets
// from the external master sync interface to the endpoint buffer...

```

Figure 9-45. Code Example, Synchronous Slave FIFO IN Data Transfer



### 9.3.11 Auto-Mode Example: Asynchronous FIFO IN Data Transfers

The initialization code is exactly the same as for the synchronous-transfer example in Section 9.3.10, but with IFCLK configured for internal use at a rate of 48 MHz and the ASYNC bit set to 1. Figure 9-46 shows the one-line modification that's needed.

```
TD_Init( ): // slight modification from our synchronous firmware example
IFCONFIG = 0xCB;
// this defines the external interface as follows:
// use internal IFCLK (48MHz)
// use slave FIFO interface pins asynchronously to external master
```

*Figure 9-46. TD\_Init Example, Asynchronous Slave FIFO IN Data Transfers*

Code to perform the transfers is, as before, unnecessary; as Figure 9-47 illustrates.

```
TD_Poll( ):
// nothing! The FX2 is doing all the work of transferring packets
// from the external master async interface to the endpoint buffer...
```

*Figure 9-47. TD\_Poll Example, Asynchronous Slave FIFO IN Data Transfers*



---

## Chapter 10 General Programmable Interface (GPIF)

---

### 10.1 Introduction

---

The General Programmable Interface (GPIF) is an *internal master* to the FX2's endpoint FIFOs. It replaces the external "glue" logic which might otherwise be required to build an interface between the FX2 and the outside world.

At the GPIF's core is a programmable state machine which generates up to six "control" and nine "address" outputs, and accepts six external and two internal "ready" inputs. Four user-defined *Waveform Descriptors* control the state machine; generally (but not necessarily), one is written for FIFO reads, one for FIFO writes, one for single-byte/word reads, and one for single-byte/word writes.



***"Read" and "Write" are from the FX2's point of view. "Read" waveforms transfer data from the outside world to the FX2; "Write" waveforms transfer data from the FX2 to the outside world.***

FX2 firmware can assign the FIFO-read and -write waveforms to any of the four FIFOs, and the GPIF will generate the proper strobes and handshake signals to the outside-world interface as data is transferred into or out of that FIFO.

As with external mastering (see *Chapter 9 "Slave FIFOs"*), the data bus between the FIFOs and the outside world can be either 8 or 16 bits wide.

The GPIF is not limited to simple handshaking interfaces between the FX2 and external ASICs or microprocessors; it's powerful enough to directly implement such protocols as ATAPI (PIO and UDMA), IEEE 1284 (EPP Parallel Port), Utopia, etc. An FX2 can, for instance, function as a single-chip interface between USB and an IDE hard disk drive or CompactFlash™ memory card.

This chapter provides an overview of GPIF, discusses external connections, and explains the operation of the GPIF engine. Figure 10-1 presents a block diagram illustrating GPIF's place in the FX2 system.



*GPIF waveforms are generally created with the Cypress GPIFTool utility, a Windows™-based application which is distributed with the Cypress EZ-USB FX2 Development Kit. Although this*

chapter will describe the structure of the Waveform Descriptors in some detail, knowledge of that structure is usually **not** necessary. The GPIFTool simply hides the complexity of the Waveform Descriptors; it doesn't compromise the programmer's control over the GPIF in any way.

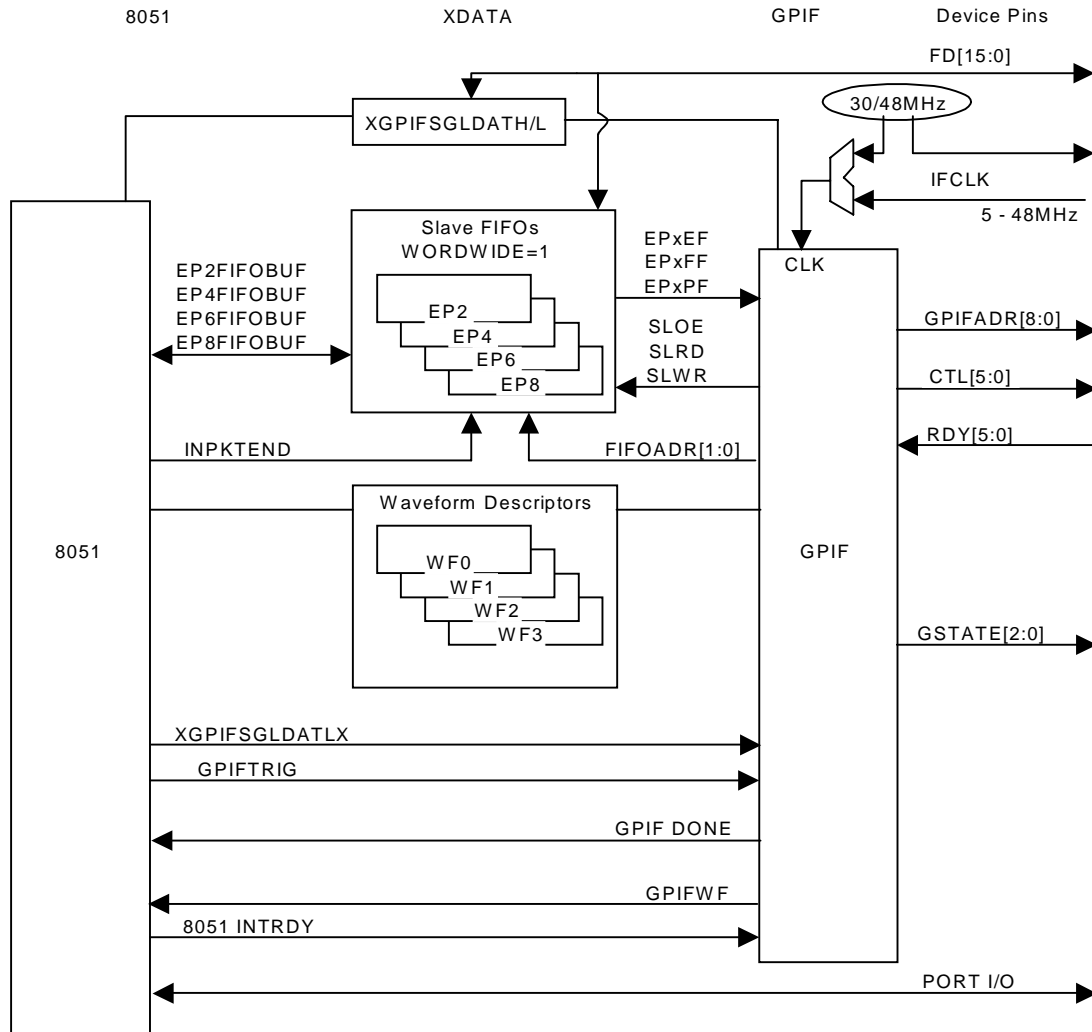

Figure 10-1. GPIF's Place in the FX2 System

Figure 10-2 shows an example of a simple GPIF transaction. For this transaction, the GPIF generates an address (GPIFADR[8:0]), drives the FIFO data bus (FD[15:0]), then waits for an externally-supplied handshake signal (RDY0) to go low, after which it pulls its CTL0 output low. When the RDY0 signal returns high, the GPIF brings its CTL0 output high, then floats the data bus.

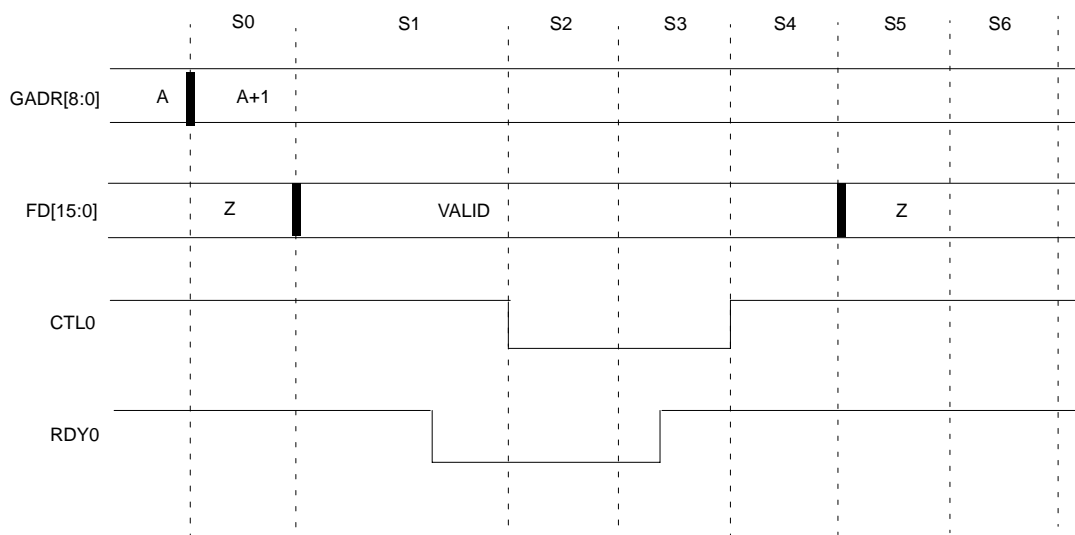

Figure 10-2. Example GPIF Waveform

### 10.1.1 Typical GPIF Interface

The GPIF allows the EZ-USB FX2 to connect directly to external peripherals such as ASICs, DSPs, or other digital logic that uses an 8- or 16-bit parallel interface.

The GPIF provides external pins that can operate as outputs (CTL[5:0]), inputs (RDY[5:0]), Data bus (FD[15:0]), and Address Lines (GPIFADR[8:0]).

A Waveform Descriptor in internal RAM describes the behavior of each of the GPIF signals. The Waveform Descriptor is loaded into the GPIF registers by the FX2 firmware during initialization, and it is then used throughout the execution of the code to perform transactions over the GPIF interface.

Figure 10-3 shows a block diagram of a typical interface between the EZ-USB FX2 and a peripheral function.

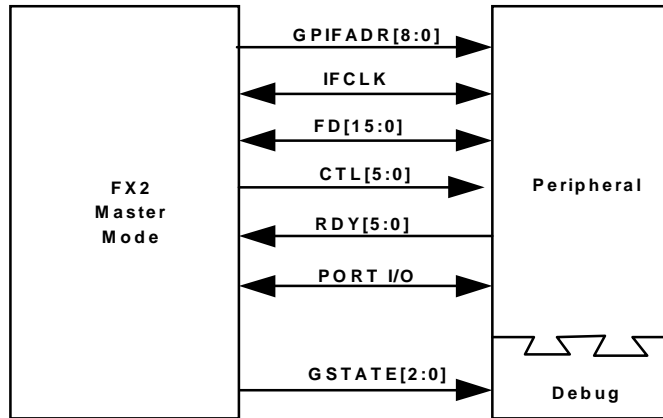

Figure 10-3. EZ-USB FX2 Interfacing to a Peripheral

The following sections detail the features available and steps needed to create an efficient GPIF design. This includes definition of the external GPIF connections and the internal register settings, along with FX2 firmware needed to execute data transactions over the interface.

## 10.2 Hardware

Table 10-1 lists the registers associated with the GPIF hardware; a detailed description of each register may be found in *Chapter 15, "Registers."*

*Table 10-1. Registers Associated with GPIF Hardware*

GPIFIDLECS	IFCONFIG
GPIFIDLECTL	FIFORESET
GPIFCTLCFG	EPxCFG
PORTCCFG	EPxFIFOCFG
PORTECFG	EPxAUTOINLENH/L
GPIFADRH/L	EPxFIFOPFH/L
EPxGPIFTCH/L	
GPIFWFSELECT	EPxTRIG
EPxGPIFFLGSEL	ABORT
EPxGPIFPFSTOP	XGPIFSGLDATH/LX/LNOX
GPIFREADYCFG	GPIFSGLDATH/LX/NOX
GPIFREADYSTAT	GPIFTRIG

Note: The "x" in these register names represents 2, 4, 6, or 8; endpoints 0 and 1 are not associated with the GPIF.

### 10.2.1 The External GPIF Interface

The GPIF provides many general input and output signals with which external peripherals may be interfaced *gluelessly* to the FX2.

The GPIF interface signals are shown in Table 10-2.

*Table 10-2. GPIF Pin Descriptions*

PIN	IN/OUT	Description
CTL[5:0]	O / Hi-Z	Programmable control outputs
RDY[5:0]	I	Sampleable ready inputs
FD[15:0]	I / O / Hi-Z	Bidirectional FIFO data bus
GPIFADR[8:0]	O / Hi-Z	Address outputs
IFCLK	I / O	Interface clock
GSTATE[2:0]	O / Hi-Z	Current GPIF State number (for debug)

The Control Output pins (CTL[5:0]) are usually used as strobes (enable lines), read/write lines, and other non-bused outputs.

The Ready Input pins (RDY[5:0]) are sampled by the GPIF and can force a transaction to wait (inserting wait states), continue, or repeat until they're in a particular state.

The GPIF Data Bus is a collection of the FD[15:0] pins.

- An 8-bit wide GPIF interface uses pins FD[7:0].
- A 16 bit-wide GPIF interface uses pins FD[15:0].

The GPIF Address lines (GPIFADR[8:0]) can generate an incrementing address as data is transferred. If higher-order address lines are needed, other non-GPIF I/O signals (i.e., general-purpose I/O pins) may be used.

The Interface Clock, IFCLK, can be configured to be either an input (default) or an output interface clock for synchronous interfaces to external logic.

The GSTATE[2:0] pins are outputs which show the current GPIF State number; they are typically used only when debugging GPIF waveforms.

---

### **10.2.2 Default GPIF Pins Configuration**

The FX2 comes out of reset with its I/O pins configured in "Ports" mode, not "GPIF Master" mode. To configure the pins for GPIF mode, the IFCFG1:0 bits in the IFCONFIG register must be set to 10 (see Table 13-10, "IFCFG Selection of Port I/O Pin Functions" for details).



### 10.2.3 Six Control OUT signals

The 100- and 128-pin FX2 packages bring out all six Control Output pins, CTL[5:0]. The 56-pin package brings out three of these signals, CTL[2:0]. CTLx waveform edges can be programmed to make transitions as often as once per IFCLK clock (once every 20.8 ns if IFCLK is running at 48MHz).

By default, these signals are driven high.

#### 10.2.3.1 Control Output Modes

The GPIF Control pins (CTL[5:0]) have several output modes:

- CTL[3:0] can act as CMOS outputs (optionally tristatable) or open-drain outputs.
- CTL[5:4] can act as CMOS outputs or open-drain outputs.

If CTL[3:0] are configured to be tristatable, CTL[5:4] are not available.

Table 10-3. CTL[5:0] Output Modes

TRICTL (GPIFCTLCFG.7)	GPIFCTLCFG[6:0]	CTL[3:0]	CTL[5:4]
0	0	CMOS, Not Tristatable	CMOS, Not Tristatable
0	1	Open-Drain	Open-Drain
1	X	CMOS, Tristatable	Not Available

### 10.2.4 Six Ready IN signals

The 100- and 128-pin FX2 packages bring out all six Ready inputs, RDY[5:0]. The 56-pin package brings out two of these signals, RDY[1:0].

The RDY inputs can be sampled synchronously or asynchronously. When the GPIF is in asynchronous mode (SAS=1), the RDY inputs are unavoidably delayed by a small amount (approximately 24 ns at 48 MHz IFCLK). In other words, when the GPIF “looks” at a RDY input, it actually “sees” the state of that input 24 ns ago.

### 10.2.5 Nine GPIF Address OUT signals

Nine GPIF address lines, GPIFADR[8:0], are available. If the GPIF address lines are configured as outputs, writing to the GPIFADRH:L registers drives these pins immediately. The GPIF engine can then increment them under control of the Waveform Descriptors. The GPIF address lines can be tristated by clearing the associated PORTxCFG bits and OEx bits to 0 (see Section 13.3.3, "Port C Alternate Functions" and Section 13.3.4, "Port E Alternate Functions").

---

### 10.2.6 Three GSTATE OUT signals

Three GPIF State lines, GSTATE[2:0], are available as an alternate configuration of PORTE[2:0]. These default to general-purpose inputs; setting GSTATE (IFCONFIG.2) to 1 selects the alternate configuration and overrides PORTECFG[2:0] bit settings.

The GSTATE[2:0] pins output the current GPIF State number; this feature is typically used only while debugging GPIF waveforms.

---

### 10.2.7 8/16-Bit Data Path, WORDWIDE = 1 (default) and WORDWIDE = 0

When the FX2 is configured for GPIF Master mode, PORTB is always configured as FD[7:0].

If *any* of the WORDWIDE bits (EPxFIFOCFG.0) are set to 1, PORTD is automatically configured as FD[15:8]. If all the WORDWIDE bits are cleared to 0, PORTD is available for general-purpose I/O.

---

### 10.2.8 Byte Order for 16-bit GPIF Transactions

Data is sent over USB in packets of 8-bit bytes, not 16-bit words. When the FIFO Data bus is 16 bits wide, the first byte in every pair sent over USB is transferred over FD[7:0] and the second byte is transferred over FD[15:8].

---

### 10.2.9 Interface Clock (IFCLK)

The GPIF interface can be clocked from either an internal or an external source. The FX2's internal clock source can be configured to run at either 30 or 48 MHz, and it can optionally be output on the IFCLK pin. If the FX2 is configured to use an external clock source, the IFCLK pin can be driven at any frequency between 5 MHz and 48 MHz. On power-on reset, the FX2 defaults to the internal source at 48 MHz, normal polarity, with the IFCLK output disabled. See Figure 10-4.

IFCONFIG.7 selects between internal and external sources: 0 = external, 1 = internal.

IFCONFIG.6 selects between the 30- and 48-MHz internal clock: 0 = 30 MHz, 1 = 48 MHz. This bit has no effect when IFCONFIG.7 = 0.

IFCONFIG.5 is the output enable for the internal clock source: 0 = disable, 1 = enable. This bit has no effect when IFCONFIG.7 = 0.

IFCONFIG.4 inverts the polarity of the interface clock (whether it's internally or externally sourced): 0 = normal, 1 = inverted. IFCLK inversion can make it easier to interface the FX2 with certain external circuitry; Figure 10-5, for example, demonstrates the use of IFCLK inversion in order to ensure a long-enough setup time for reading peripheral signals.



When IFCLK is configured as an input, the minimum external frequency that can be applied to it is 5 MHz.

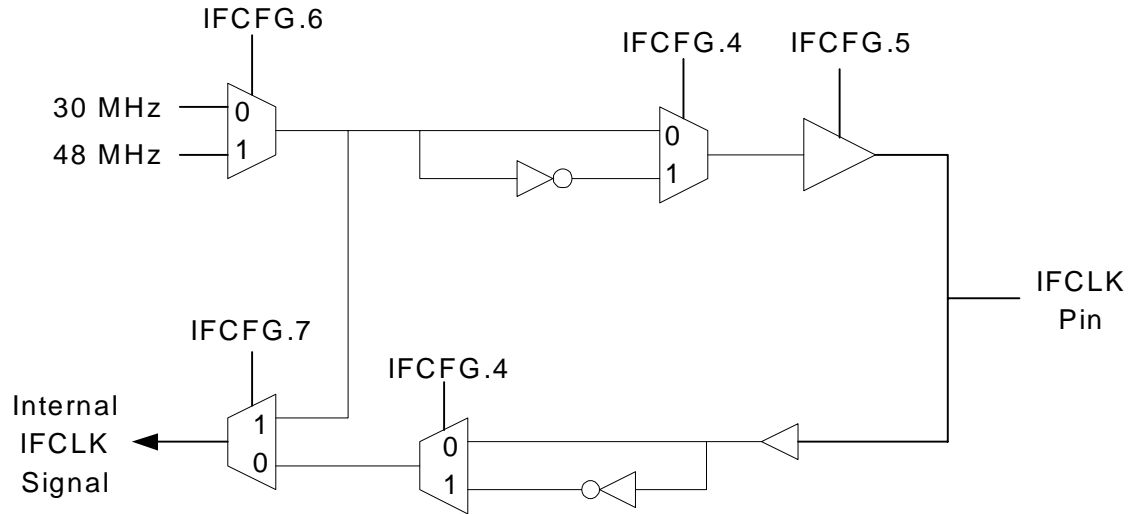

Figure 10-4. IFCLK Configuration

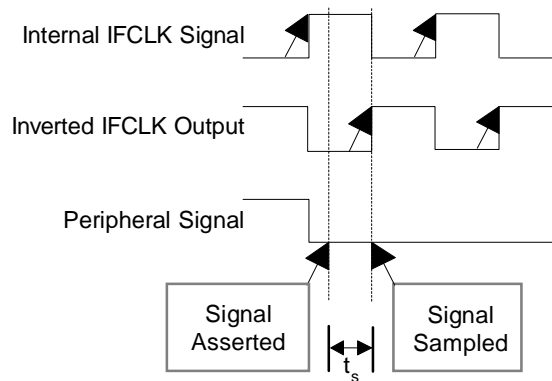

Figure 10-5. Satisfying Setup Timing by Inverting the IFCLK Output

## 10.2.10 Connecting GPIF Signal Pins to Hardware

The first step in creating the interface between the FX2's GPIF and an external peripheral is to define the hardware interconnects.

1. **Choose IFCLK settings.** Decide whether to use an asynchronous or synchronous interface. If synchronous, choose either the internal or external interface clock. If internal, choose either 30 or 48 MHz; if external, ensure that the frequency of the external clock is in the range 5-48 MHz.
2. **Determine the proper FIFO Data Bus size.** If the data bus for the interface is 8 bits wide, use the FD[7:0] pins and set WORDWIDE=0. If the data bus for the interface is 16 bits wide, use FD[15:0] and set WORDWIDE=1.
3. **Assign the CTLx signals to the interface.** Make a list of all interface signals to be driven from the GPIF to the peripheral, and assign them to the CTL[5:0] inputs. If there are more output signals than available CTL outputs, non-GPIF I/O signals must be driven manually by FX2 firmware. In this case, the CTLx outputs should be assigned only to signals that must be driven as part of a data transaction.
4. **Assign the RDYn signals to the interface.** Make a list of all interface signals to be driven from the peripheral to the GPIF, and assign them to the RDY[5:0] inputs. If there are more input signals than available RDY inputs, non-GPIF I/O signals must be sampled manually by FX2 firmware. In this case, the RDYn inputs should be used only for signals that must be sampled as part of a data transaction.
5. **Determine the proper GPIF Address connections.** If the interface uses an Address Bus, use the GPIFADR[8:0] signals for the least significant bits, and other non-GPIF I/O signals for the most significant bits. If the address pins are not needed (as when, for instance, the peripheral is a FIFO) they may be left unconnected.

## 10.2.11 Example GPIF Hardware Interconnect

The following example illustrates the hardware connections that can be made for a standard interface to a 27C256 EPROM.

Table 10-4. Example GPIF Hardware Interconnect

Step	Result	Connection Made
1. Choose IFCLK settings.	Internal IFCLK, 48MHz, Async, GPIF.	No connection.
2. Determine proper FIFO Data Bus size.	8 bits from the EPROM.	FD[7:0] to D[7:0]. Firmware writes WORDWIDE=0.
3. Assign CTLx signals to the interface.	CS and OE are inputs to the EPROM.	CTL0 to $\overline{CS}$ . CTL1 to $\overline{OE}$ .
4. Assign RDYn signals to the interface.	27C256 EPROM has no output ready/wait signals.	No connection.
5. Determine the proper GPIFADR connections.	16 bits of address.	GPIFADR[8:0] to A[8:0] and other I/O pins to A[15:9].

The process is the same for larger, more-complicated interfaces.

## 10.3 Programming the GPIF Waveforms

Each GPIF Waveform Descriptor can define up to 7 States. In each State, the GPIF can be programmed to:

- Drive (high or low) or float the CTL outputs
- Sample or drive the FIFO Data bus
- Increment the value on the GPIF Address bus
- Increment the pointer into the current FIFO
- Trigger a GPIFWF (GPIF Waveform) interrupt

Additionally, each State may either sample any two of the following:

- The RDYx input pins
- A FIFO flag
- The INTRDY (internal RDY) flag
- The Transaction-Count-Expired flag

then AND, OR, or XOR the two terms and branch on the result to any State

or:

- Delay a specified number [1-256] of IFCLK cycles

States which sample and branch are called “Decision Points” (DPs); States which don’t are called “Non-Decision Points” (NDPs).

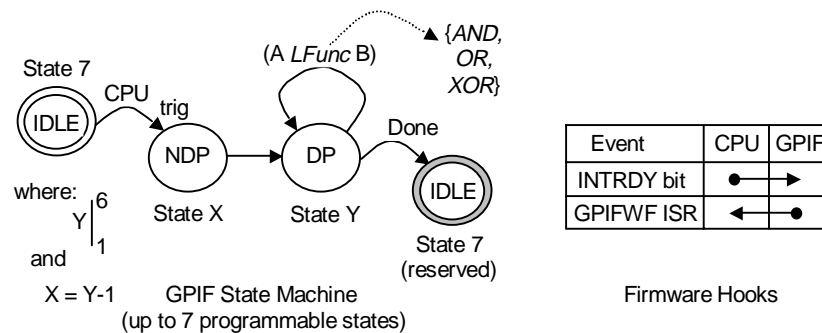

Figure 10-6. GPIF State Machine Overview

---

### 10.3.1 The GPIF Registers

Two blocks of registers control the GPIF state machine:

- **GPIF Configuration Registers** — These registers configure the general settings and report the status of the interface. Refer to *Chapter 15, "Registers,"* and the remainder of this chapter for details.
- **Waveform Registers** — These registers are loaded with the Waveform Descriptors that configure the GPIF state machine; there are a total of 128 bytes located at addresses 0xE400 to 0xE47F. *It is strongly recommended that the GPIFTool utility be used to create Waveform Descriptors.*

GPIF transactions cannot be initiated until the Configuration Registers and Waveform Registers are loaded by FX2 firmware.

Access to the waveform registers is only allowed while the FX2 is in GPIF mode (i.e., IFCFG1:0 = 10). The waveform registers may only be written while the GPIF engine is halted (i.e., DONE = 1).

If it's desired to dynamically reconfigure Waveform Descriptors, this may be accomplished by writing just the bytes which change; it's not necessary to reload the entire set of Waveform Descriptors in order to modify only a few bytes.

---

### 10.3.2 Programming GPIF Waveforms

The "programs" for GPIF waveforms are the *Waveform Descriptors*, which are stored in the Waveform Registers by FX2 firmware.

The FX2 can hold up to four Waveform Descriptors, each of which can be used for one of four types of transfers: Single Write, Single Read, FIFO Write, or FIFO Read. By default, one Waveform Descriptor is assigned to each transfer type, but it's not necessary to retain that configuration; all four Waveform Descriptors could, for instance, be configured for FIFO Write usage (see the GPIFWFSELECT register in *Chapter 15 "Registers"*).

Each Waveform Descriptor consists of up to seven 32-bit *State Instructions* that program key transition points for GPIF interface signals. There's a one-to-one correspondence between the State Instructions and the GPIF state-machine States. Among other things, each State Instruction defines the state of the CTLx outputs, the state of FD[15:0], the use of the RDYn inputs, and the behavior of GPIFADR[8:0].

Transitions from one State to another happen on a rising edge of the IFCLK, but the GPIF may remain in one State for many IFCLK cycles.

#### 10.3.2.1 The GPIF IDLE State

A Waveform consists of *up to* seven programmable States, numbered S0 to S6, and one special *Idle State*, S7. **A Waveform terminates when the GPIF program branches to its Idle State.**

To complete a GPIF transaction, the GPIF program must branch to the IDLE State, *regardless of the State that the GPIF program is currently executing*. For example, a GPIF Waveform might be defined by a program which contained only 2 programmed States, S0 and S1. The GPIF program would branch from S1 (or S0) to S7 when it wished to terminate.

The state of the GPIF signals during the Idle State is determined by the contents of the GPIFIDLECS and GPIFIDLECTL registers.

Once a waveform is triggered, another waveform may not be started until the first one terminates. Termination of a waveform is signaled through the DONE bit (GPIFIDLECS.7 or GPIFTRIG.7) or, optionally, through the GPIFDONE interrupt.

- If DONE = 0, the GPIF is *busy* generating a Waveform.
- If DONE = 1, the GPIF is *done* (GPIF is in the Idle State) and ready for firmware to start the next GPIF transaction.



**Important:** *With one exception (writing to the GPIFABORT register in order to force the current waveform to terminate) it is illegal to write to any of the GPIF-related registers (including the Waveform Registers) while the GPIF is busy. Doing so will cause indeterminate behavior likely to result in data corruption.*

#### 10.3.2.1.1 GPIF Data Bus During IDLE

During the Idle State, the GPIF Data Bus (FD[15:0]) can be either driven or tristated, depending on the setting of the IDLEDRV bit (GPIFIDLECS.0):

- If IDLEDRV = 0, the GPIF Data Bus is tristated during the Idle State.
- If IDLEDRV = 1, the GPIF Data Bus is actively driven during the Idle State, to the value last placed on the bus by a GPIF Waveform.

#### 10.3.2.1.2 CTL Outputs During IDLE

During the IDLE State, the state of CTL[5:0] depends on the following register bits:

- TRICTL (GPIFCTLCFG.7), as described in Section 10.2.3.1, "Control Output Modes".
- GPIFCTLCFG[5:0]
- GPIFIDLECTL[5:0].

The combination of these bits defines CTL5:0 during IDLE as follows:

- If TRICTL is 0, GPIFIDLECTL[5:0] directly represent the output states of CTL5:0 during the IDLE State. The GPIFCTLCFG[5:0] bits determine whether the CTL5:0 outputs are CMOS or open-drain: If GPIFCTLCFG.x = 0, CTLx is CMOS; if GPIFCTLCFG.x = 1, CTLx is open-drain.

- If TRICTL is 1, GPIFIDLECTL[7:4] are the output enables for the CTL[3:0] signals, and GPIFIDLECTL[3:0] are the output values for CTL[3:0]. CTL4 and CTL5 are unavailable in this mode.

Table 10-5 illustrates this relationship.

Table 10-5. Control Outputs (CTLn) During the IDLE State

TRICTL	Control Output	Output State	Output Enable
0	CTL0	GPIFIDLECTL.0	N/A (CTL Outputs are always enabled when TRICTL = 0)
	CTL1	GPIFIDLECTL.1	
	CTL2	GPIFIDLECTL.2	
	CTL3	GPIFIDLECTL.3	
	CTL4	GPIFIDLECTL.4	
	CTL5	GPIFIDLECTL.5	
1	CTL0	GPIFIDLECTL.0	GPIFIDLECTL.4
	CTL1	GPIFIDLECTL.1	GPIFIDLECTL.5
	CTL2	GPIFIDLECTL.2	GPIFIDLECTL.6
	CTL3	GPIFIDLECTL.3	GPIFIDLECTL.7
	CTL4	N/A (CTL4 and CTL5 are not available when TRICTL = 1)	
	CTL5		

### 10.3.2.2 Defining States

Each Waveform is made up of a number of States, each of which is defined by a 32-bit State Instruction. Each State can be one of two basic types: a *Non-Decision Point* (NDP) or a *Decision Point* (DP).

For “write” waveforms, the data bus is either driven or tristated during each State. For “read” waveforms, the data bus is either sampled/stored or not sampled during each State.

#### 10.3.2.2.1 Non-Decision Point (NDP) States

For NDP States, the control outputs (CTLx) are defined by the GPIF instruction to be either 1, 0, or tristated during the entire State. NDP States have a programmable fixed duration in units of IFCLK cycles.

Figure 10-7 illustrates the basic concept of NDP States. A write waveform is shown, and for simplicity all the States are shown with equal spacing. Although there are a total of six programmable CTL outputs, only one (CTL0) is shown in Figure 10-7.



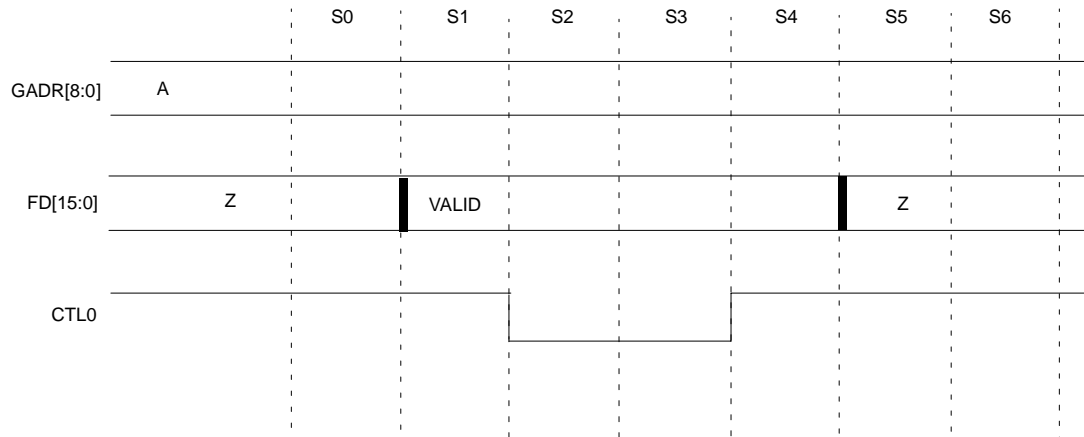

Figure 10-7. Non-Decision Point (NDP) States

Referring to Figure 10-7:

**In State 0:**

- FD[7:0] is programmed to be tristated.
- CTL0 is programmed to be driven to a logic 1.

**In State 1:**

- FD[7:0] is programmed to be driven.
- CTL0 is still programmed to be driven to a logic 1.

**In State 2:**

- FD[7:0] is programmed to be driven.
- CTL0 is programmed to be driven to a logic 0.

**In State 3:**

- FD[7:0] is programmed to be driven.
- CTL0 is still programmed to be driven to a logic 0.

**In State 4:**

- FD[7:0] is programmed to be driven.
- CTL0 is programmed to be driven to a logic 1.

**In State 5:**

- FD[7:0] is programmed to be tristated.
- CTL0 is still programmed to be driven to a logic 1.

**In State 6:**

- FD[7:0] is programmed to be tristated.
- CTL0 is still programmed to be driven to a logic 1.

Since all States in this example are coded as NDPs, the GPIF automatically branches from the last State (S6) to the Idle State (S7). This is the State in which the GPIF waits until the next GPIF waveform is triggered by the firmware.

States 2 and 3 in the example are identical, as are States 5 and 6. In a real application, these would probably be combined (there's no need to duplicate a State in order to "stretch" it, since each NDP State can be assigned a duration in terms of IFCLK cycles). If fewer than 7 States were defined for this waveform, the Idle State wouldn't automatically be entered after the last programmed State; that last programmed State's State Instruction would have to include an explicit branch to the Idle State.

#### 10.3.2.2.2 Decision Point (DP) States

Any State can be designated as a Decision Point (DP). A DP allows the GPIF engine to sample two signals — each of the "two" can be the same signal, if desired — perform a boolean operation on the sampled values, then branch to other States (or loop back on itself, remaining in the current State) based on the result.

If a State Instruction includes a control task (advance the FIFO pointer, increment the GPIFADR address, etc.), that task is always executed once upon entering the State, regardless of whether the State is a DP or NDP. If the State is a DP that loops back on itself, however, it can be programmed to re-execute the control task on every loop.

With a Decision Point, the GPIF can perform simple tasks (wait until a RDY line is low before continuing to the next State, for instance). Decision point States can also perform more-complex tasks by branching to one State if the operation on the sampled signals results in a logic 1, or to a different State if it results in a logic 0.

In each State Instruction, the two signals to sample can be selected from any of the following:

- the six external RDY signals (RDY0-RDY5)
- one of the current FIFO's flags (PF, EF, FF)
- the INTRDY bit in the READY register
- a "Transaction Count Expired" signal (which replaces RDY5)

The State Instruction also specifies a logic function (AND, OR, or XOR) to be applied to the two selected signals. If it's desired to act on the state of only one signal, the usual procedure is to select the same signal twice and specify the logic function as AND.

The State Instruction also specifies which State to branch to if the result of the logical expression is 0, and which State to branch to if the result of the logical expression is 1.

Below is an example waveform created using one Decision Point State (State 1); Non-Decision Point States are used for the rest of the waveform.

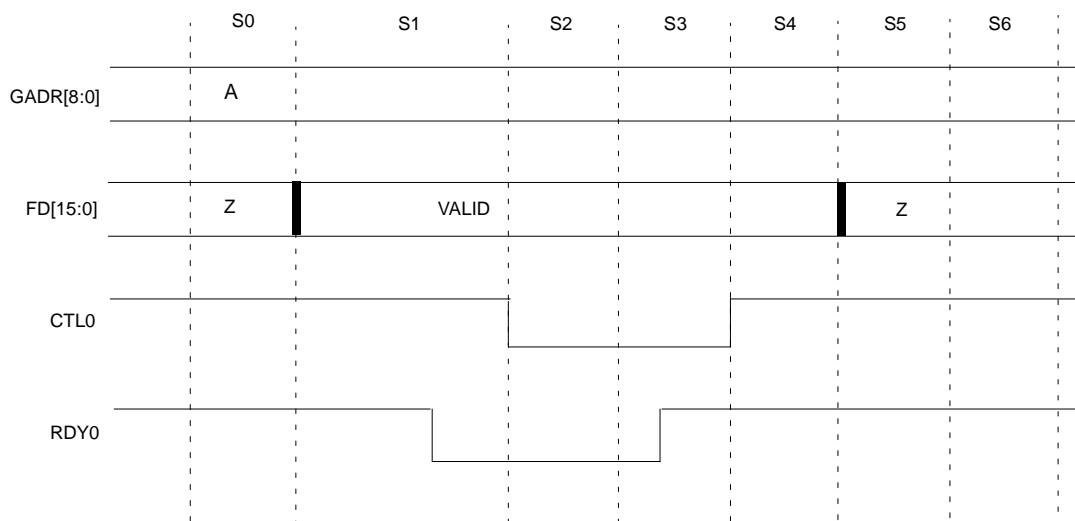

*Figure 10-8. One Decision Point: Wait States Inserted Until RDY0 Goes Low*

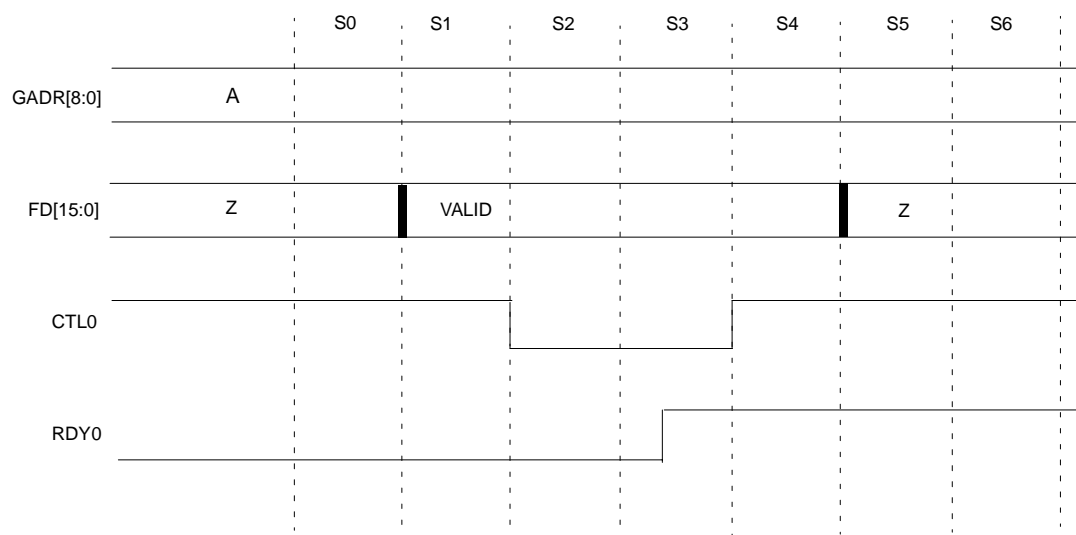

*Figure 10-9. One Decision Point: No Wait States Inserted: RDY0 is Already Low at Decision Point I1*

In Figure 10-8 and Figure 10-9, there is a single Decision Point defined as State 1. In this example, the input ready signal is assumed to be connected to RDY0, and the State Instruction for S1 is configured to branch to State 2 if RDY0 is a logic 0 or to branch to State 1 (i.e., loop indefinitely) if RDY0 is a logic 1.

In Figure 10-8, the GPIF remains in S1 until the RDY0 signal goes low, then branches to S2. Figure 10-9 illustrates the GPIF behavior when the RDY0 signal is *already* low when S1 is entered: The GPIF branches to S2.



Although it appears in Figure 10-8 that the GPIF branches **immediately** from State 0 to State 2, this isn't exactly true. Even if RDY0 is already low before the GPIF enters State 1, the GPIF spends one IFCLK cycle in State 1.

---

### 10.3.3 Re-Executing a Task Within a DP State

In the simple DP examples shown earlier in this chapter, a control task (e.g., output a word on FD[15:0] and increment GPIFADR[8:0]) executes only once at the start of a DP State, then the GPIF waits, sampling a RDYx input repeatedly until that input “tells” the GPIF to branch to the next State.

The GPIF also has the capability to re-execute the control task every time the RDYx input is sampled; this feature can be used to burst a large amount of data without passing through the Idle State.

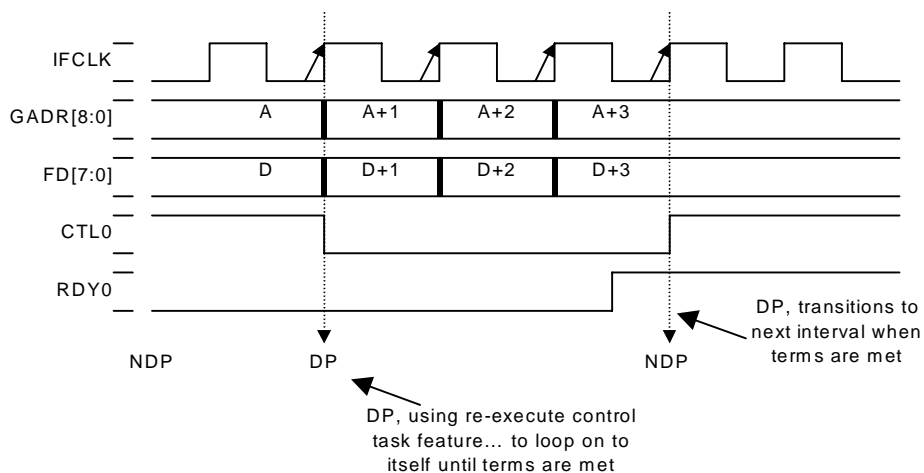

Figure 10-10. Re-Executing a Task within a DP State

State	0	1	2	3	4	5	6	7
AddrMode	Same Val	Inc Val	Same Val	Same Val	Same Val	Same Val	Same Val	
DataMode	Activate	Activate	NO Data	NO Data	NO Data	NO Data	NO Data	
NextData	SameData	NextData	SameData	SameData	SameData	SameData	SameData	
Int Trig	No Int	No Int	No Int	No Int	No Int	No Int	No Int	
IF/Wait	Wait 4	IF	Wait 1	Wait 1	Wait 1	Wait 1	Wait 1	
Term A		RDY0						
LFUNC		AND						
Term B		RDY0						
Branch1		Then 2						
Branch0		Else 1						
Re-execute		Yes						
CTL0	1	0	1	1	1	1	1	1
CTL1	1	1	1	1	1	1	1	1
CTL2	1	1	1	1	1	1	1	1
CTL3	1	1	1	1	1	1	1	1
CLT4	1	1	1	1	1	1	1	1
CTL5	1	1	1	1	1	1	1	1

Figure 10-11. GPIFTool Setup for the Waveform of Figure 10-10

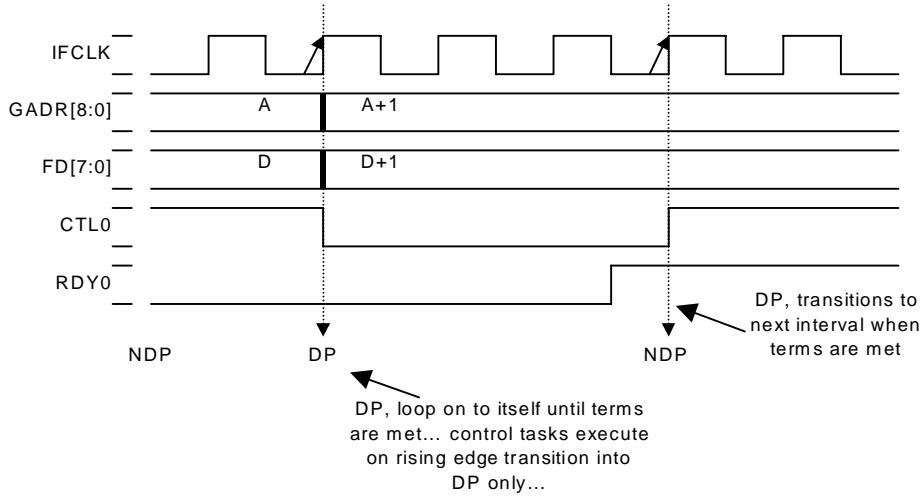

Figure 10-12. A DP State Which Does NOT Re-Execute the Task

State	0	1	2	3	4	5	6	7
AddrMode	Same Val	Inc Val	Same Val	Same Val	Same Val	Same Val	Same Val	
DataMode	Activate	Activate	NO Data	NO Data	NO Data	NO Data	NO Data	
NextData	SameData	NextData	SameData	SameData	SameData	SameData	SameData	
Int Trig	No Int	No Int	No Int	No Int	No Int	No Int	No Int	No Int
IF/Wait	Wait 4	IF	Wait 1	Wait 1	Wait 1	Wait 1	Wait 1	
Term A		RDY0						
LFUNC		AND						
Term B		RDY0						
Branch1		Then 2						
Branch0		Else 1						
Re-execute		No						
CTL0	1	0	1	1	1	1	1	1
CTL1	1	1	1	1	1	1	1	1
CTL2	1	1	1	1	1	1	1	1
CTL3	1	1	1	1	1	1	1	1
CLT4	1	1	1	1	1	1	1	1
CTL5	1	1	1	1	1	1	1	1

Figure 10-13. GPIFTool Setup for the Waveform of Figure 10-12

### 10.3.4 State Instructions

Each State's characteristics are defined by a 4-byte State Instruction. The four bytes are named *LENGTH / BRANCH*, *OPCODE*, *LOGIC FUNCTION*, and *OUTPUT*.

Note that the State Instructions are interpreted differently for Decision Points (DP = 1) and Non-Decision Points (DP = 0).

#### **Non-Decision Point State Instruction (DP = 0)**

##### LENGTH / BRANCH

Bit 7	Bit 6	Bit 5	Bit 4	Bit 3	Bit 2	Bit 1	Bit 0
Number of IFCLK cycles to stay in this State (0 = 256 cycles)							

##### OPCODE

7	6	5	4	3	2	1	0
x	x	SGL	GINT	INCAD	NEXT/ SGLCRC	DATA	DP = 0

##### LOGIC FUNCTION

7	6	5	4	3	2	1	0
Not Used							

##### OUTPUT (if TRICTL Bit = 1)

7	6	5	4	3	2	1	0
OE3	OE2	OE1	OE0	CTL3	CTL2	CTL1	CTL0

##### OUTPUT (if TRICTL Bit = 0)

7	6	5	4	3	2	1	0
x	x	CTL5	CTL4	CTL3	CTL2	CTL1	CTL0

### Decision Point State Instruction (DP = 1)

#### LENGTH / BRANCH

Bit 7	Bit 6	Bit 5	Bit 4	Bit 3	Bit 2	Bit 1	Bit 0
Re-Execute	x	BRANCHON1			BRANCHON1		

#### OPCODE

7	6	5	4	3	2	1	0
x	x	SGL	GINT	INCAD	NEXT/ SGLCRC	DATA	DP = 1

#### LOGIC FUNCTION

7	6	5	4	3	2	1	0
LFUNC		TERMA			TERMB		

#### OUTPUT (if TRICTL Bit = 1)

7	6	5	4	3	2	1	0
OE3	OE2	OE1	OE0	CTL3	CTL2	CTL1	CTL0

#### OUTPUT (if TRICTL Bit = 0)

7	6	5	4	3	2	1	0
x	x	CTL5	CTL4	CTL3	CTL2	CTL1	CTL0

**LENGTH / BRANCH Register:** This register's interpretation depends on the DP bit:

- For DP = 0 (Non-Decision Point), this is a LENGTH field; it holds the fixed duration of this State in IFCLK cycles. A value of 0 is interpreted as 256 IFCLK cycles.
- For DP = 1 (Decision Point), this is a BRANCH field; it specifies the State to which the GPIF will branch:

**BRANCHON1:** Specifies the State to which the GPIF will branch if the logic expression evaluates to 1.

**BRANCHON0:** Specifies the State to which the GPIF will branch if the logic expression evaluates to 0.



**OPCODE Register:** This register sets a number of State characteristics.

**SGL Bit:** has no effect in a Single-Read or Single-Write waveform. In a FIFO waveform, it specifies whether a single-data transaction should occur (from/to the SGLDATAH:L or UDMA\_CRCH:L registers), even in a FIFO-Write or FIFO-Read transaction. See also “NEXT/SGLCRC”, below.

- 1 = Use SGLDATAH:L or UDMA\_CRCH:L.
- 0 = Use the FIFO.

**GINT Bit:** specifies whether to generate a GPIFWF interrupt during this State.

- 1 = Generate GPIFWF interrupt (on INT4) when this State is reached.
- 0 = Do not generate interrupt.

**INCAD Bit:** specifies whether to increment the GPIF Address lines GPIFADR[8:0].

- 1 = Increment the GPIFADR[8:0] bus at the beginning of this State.
- 0 = Do not increment the GPIFADR[8:0] signals.

**NEXT/SGLCRC Bit:**

If SGL = 0, specifies whether the FIFO should be advanced at the start of this State.

- 1 = Move the next data in the OUT FIFO to the top.
- 0 = Do not advance the FIFO.

The NEXT bit has no effect when the waveform is applied to an IN FIFO.

If SGL = 1, specifies whether data should be transferred to/from SGLDATAH:L or UDMA\_CRCH:L. See also “SGL Bit”, above.

- 1 = Use UDMA\_CRCH:L.
- 0 = Use SGLDATAH:L.

**DATA Bit:** specifies whether the FIFO Data bus is to be driven, tristated, or sampled.

During a write:

- 1 = Drive the FIFO Data bus with the output data.
- 0 = Tristate (don't drive the bus).

During a read:

- 1 = Sample the FIFO Data bus and store the data.
- 0 = Don't sample the data bus.

**DP Bit:** indicates whether the State is a DP or NDP:

- 1 = Decision Point.
- 0 = Non-Decision Point.

**LOGIC FUNCTION Register:** This register is used only in DP State Instructions. It specifies the inputs (TERMA and TERMB) and the Logic Function (LFUNC) to apply to those inputs. The result of the logic function determines the State to which the GPIF will branch (see also “LENGTH / BRANCH Register”, above).

**TERMA and TERMB bits:**

- = 000: RDY0
- = 001: RDY1
- = 010: RDY2
- = 011: RDY3
- = 100: RDY4
- = 101: RDY5 (or Transaction-Count Expiration, if READYCFG.5 = 1)
- = 110: FIFO flag (PF, EF, or FF), preselected via EPxGPIFFLGSEL
- = 111: INTRDY (Bit 7 of the GPIFREADYCFG register)

**LFUNC bits:**

- = 00: A AND B
- = 01: A OR B
- = 10:  $\overline{A}$  XOR B
- = 11:  $\overline{A}$  AND B

The TERMA and TERMB inputs are sampled at each rising edge of IFCLK. The logic function is applied, and the branch is taken, before the next rising edge.

This register is meaningful only for DP Instructions; when the DP bit of the OPCODE register is cleared to 0, the contents of this register are ignored.

**OUTPUT Register:** This register controls the state of the 6 Control outputs (CTL5:0) during the entire State defined by this State Instruction.

**OEn Bit:** If TRICTL = 1, specifies whether the corresponding CTLx output signal is tristated.

- 1 = Drive CTLx
- 0 = Tristate CTLx

**CTLn Bit:** specifies the state to set each CTLx signal to during this entire State.

- 1 = High level

If the CTLx bit in the GPIFCTLCFG register is set to 1, the output driver will be an open-drain.

If the CTLx bit in the GPIFCTLCFG register is set to 0, the output driver will be driven to CMOS levels.

- 0 = Low level

### 10.3.4.1 Structure of the Waveform Descriptors

Up to four different Waveforms can be defined. Each Waveform Descriptor comprises up to 7 State Instructions which are loaded into the Waveform Registers as defined in this section.

Table 10-6. Waveform Descriptor Addresses

Waveform Descriptor	Base XDATA Address
0	0xE400
1	0xE420
2	0xE440
3	0xE460

Within each Waveform Descriptor, the State Instructions are packed as described in Table 10-7, "Waveform Descriptor 0 Structure". Waveform Descriptor 0 is shown as an example. The other Waveform Descriptors follow exactly the same structure but at higher XDATA addresses.

Table 10-7. Waveform Descriptor 0 Structure

XDATA Address	Contents
0xE400	LENGTH / BRANCH [0] (LENGTH / BRANCH field of State 0 of Waveform Program 0)
0xE401	LENGTH / BRANCH [1] (LENGTH / BRANCH field of State 1 of Waveform Program 0)
0xE402	LENGTH / BRANCH [2] (LENGTH / BRANCH field of State 2 of Waveform Program 0)
0xE403	LENGTH / BRANCH [3] (LENGTH / BRANCH field of State 3 of Waveform Program 0)
0xE404	LENGTH / BRANCH [4] (LENGTH / BRANCH field of State 4 of Waveform Program 0)
0xE405	LENGTH / BRANCH [5] (LENGTH / BRANCH field of State 5 of Waveform Program 0)
0xE406	LENGTH / BRANCH [6] (LENGTH / BRANCH field of State 6 of Waveform Program 0)
0xE407	Reserved
0xE408	OPCODE[0] (OPCODE field of State 0 of Waveform Program 0)
0xE409	OPCODE[1] (OPCODE field of State 1 of Waveform Program 0)
0xE40A	OPCODE[2] (OPCODE field of State 2 of Waveform Program 0)
0xE40B	OPCODE[3] (OPCODE field of State 3 of Waveform Program 0)
0xE40C	OPCODE[4] (OPCODE field of State 4 of Waveform Program 0)
0xE40D	OPCODE[5] (OPCODE field of State 5 of Waveform Program 0)
0xE40E	OPCODE[6] (OPCODE field of State 6 of Waveform Program 0)
0xE40F	Reserved
0xE410	OUTPUT[0] (OUTPUT field of State 0 of Waveform Program 0)
0xE411	OUTPUT[1] (OUTPUT field of State 1 of Waveform Program 0)
0xE412	OUTPUT[2] (OUTPUT field of State 2 of Waveform Program 0)
0xE413	OUTPUT[3] (OUTPUT field of State 3 of Waveform Program 0)
0xE414	OUTPUT[4] (OUTPUT field of State 4 of Waveform Program 0)
0xE415	OUTPUT[5] (OUTPUT field of State 5 of Waveform Program 0)
0xE416	OUTPUT[6] (OUTPUT field of State 6 of Waveform Program 0)
0xE417	Reserved
0xE418	LOGIC FUNCTION[0] (LOGIC FUNCTION field of State 0 of Waveform Program 0)
0xE419	LOGIC FUNCTION[1] (LOGIC FUNCTION field of State 1 of Waveform Program 0)

Table 10-7. Waveform Descriptor 0 Structure (Continued)

0xE41A	LOGIC FUNCTION[2] (LOGIC FUNCTION field of State 2 of Waveform Program 0)
0xE41B	LOGIC FUNCTION[3] (LOGIC FUNCTION field of State 3 of Waveform Program 0)
0xE41C	LOGIC FUNCTION[4] (LOGIC FUNCTION field of State 4 of Waveform Program 0)
0xE41D	LOGIC FUNCTION[5] (LOGIC FUNCTION field of State 5 of Waveform Program 0)
0xE41E	LOGIC FUNCTION[6] (LOGIC FUNCTION field of State 6 of Waveform Program 0)
0xE41F	Reserved

## 10.4 Firmware

Table 10-8. Registers Associated with GPIF Firmware

GPIFTRIG (sfr)	EPxCFG
GPIFSGLDATH (sfr)	EPxFIFO CFG
GPIFSGLDATLX (sfr)	EPxAUTOINLENH/L
GPIFSGLDATLNOX (sfr)	EPxFIFOPFH/L
EPxGPIFTRIG	EP2468STAT(sfr)
XGPIFSGLDATH	EP24FIFOFLGS(sfr)
XGPIFSGLDATLX	EP68FIFOFLGS(sfr)
XGPIFSGLDATLNOX	EPxCS
GPIFABORT	EPxFIFOFLGS
GPIFIE	
GPIFIRQ	EPxFIFOIE
	EPxFIFOIRQ
EPxBCH/L	INT2IVEC
EPxFIFOBCH/L	INT4IVEC
EPxFIFOBUF	INTSETUP
INPKTEND	IE (sfr)
	IP (sfr)
	INT2CLR(sfr)
	INT4CLR(sfr)
	EIE (sfr)
	EXIF (sfr)

The “x” in these register names represents 2, 4, 6, or 8; endpoints 0 and 1 are not associated with the Slave FIFOs.

The *GPIFTool* utility, distributed with the Cypress EZ-USB FX2 Development Kit, generates C code which may be linked with the rest of an application’s source code. The *GPIFTool* output includes the following basic GPIF framework and functions:

```

TD_Init():
    ... ..
    GpifInit(); // Configures GPIF from GPIFTool generated waveform data

    // TODO: configure other endpoints, etc. here

    // TODO: arm OUT buffer(s) here

    // setup INT4 as internal source for GPIF interrupts
    // using INT4CLR (SFR), automatically enabled
    //INTSETUP |= 0x03; //Enable INT4 Autovectoring
    //GPIFIE = 0x03; // Enable GPIFDONE and GPIFWF interrupt(s)
    //EIE |= 0x04; // Enable INT4 ISR, EIE.2(EIEX4)=1

    // TODO: configure GPIF interrupt(s) to meet your needs here
    ... ..

void GpifInit( void )
{
    BYTE xdata *Source;
    BYTE xdata *Dest;
    BYTE i;
    BOOL Verified = FALSE;

    // Firmware doesn't have access to waveform registers 'til
    // the part is in GPIF mode.
    IFCONFIG = 0xF6;
    // IFCLKSRC=1, GPIF executes on internal clk source
    // xMHz=1, 48MHz internal clk rate
    // IFCLKOE=1, Drive IFCLK pin signal at 48MHz
    // IFCLKPOL=1, Invert IFCLK pin signal from internal clk
    // ASYNC=0, GPIF samples synchronous to IFCLK
    // GSTATE=1, Drive GPIF State numbers out on PORTE[2:0], debug WF
    // IFCFG[1:0]=10, FX2 in GPIF mode

    // TODO: Configure IFCONFIG appropriately for your application above

    GPIFABORT = 0xFF; // abort any waveforms pending

    // To configure EPx FIFOs, please refer to Slave FIFO TRM Chapter

    // Reset all FIFOs.

    FIFORESET = 0x80; // First, activate NAK-All to avoid race conditions.
    FIFORESET = 0x02; // Reset FIFO 2.
    FIFORESET = 0x04; // Reset FIFO 4.
    FIFORESET = 0x06; // Reset FIFO 6.
    FIFORESET = 0x08; // Reset FIFO 8.
    FIFORESET = 0x00; // Finally, deactivate NAK-All.

    // TODO: Configure Slave FIFOs here.

    GPIFREADYCFG = InitData[0];
    GPIFREADYSTAT = InitData[6];
    GPIFCTLCFG = InitData[1];
    GPIFIDLECS = InitData[2];
    GPIFIDLECTL = InitData[3];
    GPIFWFSELECT = InitData[5];

```

```

Dest = 0xE47F;

// implement RevA/B silicon errata workaround
// initialize the GPIF waveform RAM to all zeros
for (i = 0; i < 128; i++)
{
    *Dest-- = 0x00;
}

Source = &WaveForm[127];
Dest = 0xE47F;

for (i = 0; i < 128; i++)
{
    // only write non-zero registers
    if (*Source)
    {
        *Dest = *Source;
    }
    Dest--;
    Source--;
}

while (!Verified)
{
    Verified = TRUE;
    Source = &WaveForm[127];
    Dest = 0xE47F;

    for (i = 0; i < 128; i++)
    {
        if (*Dest != *Source)
        {
            *Dest = *Source;
            Verified = FALSE;
            break;
        }
        else
        {
            Dest--;
            Source--;
        }
    }
}

// Configure GPIF Address pins, output initial value,
PORTCCFG = 0xFF; // [7:0] as alt. func. GPIFADR[7:0]
PORTECFG |= 0x80; // [8] as alt. func. GPIFADR8
// GPIF address pins update when GPIFADRH/L written
GPIFADRH = 0x00; // bits[7:1] always 0
GPIFADRL = 0x00; // point to PERIPHERAL address 0x0000

// or tristate GPIFADR[8:0] pins
//PORTCCFG = 0x00; // [7:0] as port I/O
//OEC = 0x00; // and as inputs
//PORTECFG &= 0x7F; // [8] as port I/O
//OEE &= 0x7F; // and as input

```

```
// TODO: change GPIF Address pins to meet your needs
}

// Note: most of these smaller functions could be implemented as macros

// Set Address GPIFADR[8:0] to PERIPHERAL
void Peripheral_SetAddress( WORD gaddr )
{
    GPIFADRH = gaddr >> 8;
    GPIFADRL = ( BYTE )gaddr; // setup GPIF address
}

// Set EP2GPIF Transaction Count
void Peripheral_SetEP2GPIFTC( WORD xfrcnt )
{
    EP2GPIFTCH = xfrcnt >> 8; // setup transaction count
    EP2GPIFTCL = ( BYTE )xfrcnt;
}

// Set EP4GPIF Transaction Count
void Peripheral_SetEP4GPIFTC( WORD xfrcnt )
{
    EP4GPIFTCH = xfrcnt >> 8; // setup transaction count
    EP4GPIFTCL = ( BYTE )xfrcnt;
}

// Set EP6GPIF Transaction Count
void Peripheral_SetEP6GPIFTC( WORD xfrcnt )
{
    EP6GPIFTCH = xfrcnt >> 8; // setup transaction count
    EP6GPIFTCL = ( BYTE )xfrcnt;
}

// Set EP8GPIF Transaction Count
void Peripheral_SetEP8GPIFTC( WORD xfrcnt )
{
    EP8GPIFTCH = xfrcnt >> 8; // setup transaction count
    EP8GPIFTCL = ( BYTE )xfrcnt;
}

#define GPIF_FLGSELPF 0
#define GPIF_FLGSELEF 1
#define GPIF_FLGSELFF 2

// Set EP2GPIF Decision Point FIFO Flag Select (PF, EF, FF)
void SetEP2GPIFFLGSEL( WORD DP_FIFOFlag )
{
    EP2GPIFFLGSEL = DP_FIFOFlag;
}

// Set EP4GPIF Decision Point FIFO Flag Select (PF, EF, FF)
void SetEP4GPIFFLGSEL( WORD DP_FIFOFlag )
{
    EP4GPIFFLGSEL = DP_FIFOFlag;
}
```

```

// Set EP6GPIF Decision Point FIFO Flag Select (PF, EF, FF)
void SetEP6GPIFFLGSEL( WORD DP_FIFOFlag )
{
    EP6GPIFFLGSEL = DP_FIFOFlag;
}

// Set EP8GPIF Decision Point FIFO Flag Select (PF, EF, FF)
void SetEP8GPIFFLGSEL( WORD DP_FIFOFlag )
{
    EP8GPIFFLGSEL = DP_FIFOFlag;
}

// Set EP2GPIF Programmable Flag STOP, overrides Transaction Count
void SetEP2GPIFFPFSTOP( void )
{
    EP2GPIFFPFSTOP = 0x01;
}

// Set EP4GPIF Programmable Flag STOP, overrides Transaction Count
void SetEP4GPIFFPFSTOP( void )
{
    EP4GPIFFPFSTOP = 0x01;
}

// Set EP6GPIF Programmable Flag STOP, overrides Transaction Count
void SetEP6GPIFFPFSTOP( void )
{
    EP6GPIFFPFSTOP = 0x01;
}

// Set EP8GPIF Programmable Flag STOP, overrides Transaction Count
void SetEP8GPIFFPFSTOP( void )
{
    EP8GPIFFPFSTOP = 0x01;
}

// write single byte to PERIPHERAL, using GPIF
void Peripheral_SingleByteWrite( BYTE gdata )
{
    while( !( GPIFTRIG & 0x80 ) ) // poll GPIFTRIG.7 Done bit
    {
        ;
    }

    XGPIFSGLDATLX = gdata; // trigger GPIF single byte write transaction
}

// write single word to PERIPHERAL, using GPIF
void Peripheral_SingleWordWrite( WORD gdata )
{
    while( !( GPIFTRIG & 0x80 ) ) // poll GPIFTRIG.7 Done bit
    {
        ;
    }

    // using register(s) in XDATA space
    XGPIFSGLDATH = gdata >> 8;
    XGPIFSGLDATLX = gdata; // trigger GPIF single word write transaction
}

```



```
// read single byte from PERIPHERAL, using GPIF
void Peripheral_SingleByteRead( BYTE xdata *gdata )
{
    static BYTE g_data = 0x00;

    while( !( GPIFTRIG & 0x80 ) ) // poll GPIFTRIG.7 Done bit
    {
        ;
    }

    // using register(s) in XDATA space, dummy read
    g_data = XGPIFSGLDATLX; // to trigger GPIF single byte read transaction

    while( !( GPIFTRIG & 0x80 ) ) // poll GPIFTRIG.7 Done bit
    {
        ;
    }

    // using register(s) in XDATA space, GPIF read byte from PERIPHERAL here
    *gdata = XGPIFSGLDATLNOX;
}

// read single word from PERIPHERAL, using GPIF
void Peripheral_SingleWordRead( WORD xdata *gdata )
{
    BYTE g_data = 0x00;

    while( !( GPIFTRIG & 0x80 ) ) // poll GPIFTRIG.7 Done bit
    {
        ;
    }

    // using register(s) in XDATA space, dummy read
    g_data = XGPIFSGLDATLX; // to trigger GPIF single word read transaction

    while( !( GPIFTRIG & 0x80 ) ) // poll GPIFTRIG.7 Done bit
    {
        ;
    }

    // using register(s) in XDATA space, GPIF read word from PERIPHERAL here
    *gdata = ( ( WORD )XGPIFSGLDATH << 8 ) | ( WORD )XGPIFSGLDATLNOX;
}

#define GPIFTRIGWR 0
#define GPIFTRIGRD 4

#define GPIF_EP2 0
#define GPIF_EP4 1
#define GPIF_EP6 2
#define GPIF_EP8 3
```

```
// write byte(s) to PERIPHERAL, using GPIF and EPxFIFO
void Peripheral_FIFOwrite( BYTE FIFO_EpNum )
{
    while( !( GPIFTRIG & 0x80 ) ) // poll GPIFTRIG.7 Done bit
    {
        ;
    }

    // trigger FIFO write transaction(s), using SFR
    GPIFTRIG = FIFO_EpNum; // R/W=0, EP[1:0]=FIFO_EpNum for EPx write(s)
}

// read(s) from PERIPHERAL, using GPIF and EPxFIFO
void Peripheral_FIFOread( BYTE FIFO_EpNum )
{
    while( !( GPIFTRIG & 0x80 ) ) // poll GPIFTRIG.7 GPIF Done bit
    {
        ;
    }

    // trigger FIFO read transaction(s), using SFR
    GPIFTRIG = GPIFTRIGRD | FIFO_EpNum; // R/W=1, EP[1:0]=FIFO_EpNum
                                        // for EPx read(s)
}
}
```

## 10.4.1 Single-Read Transactions

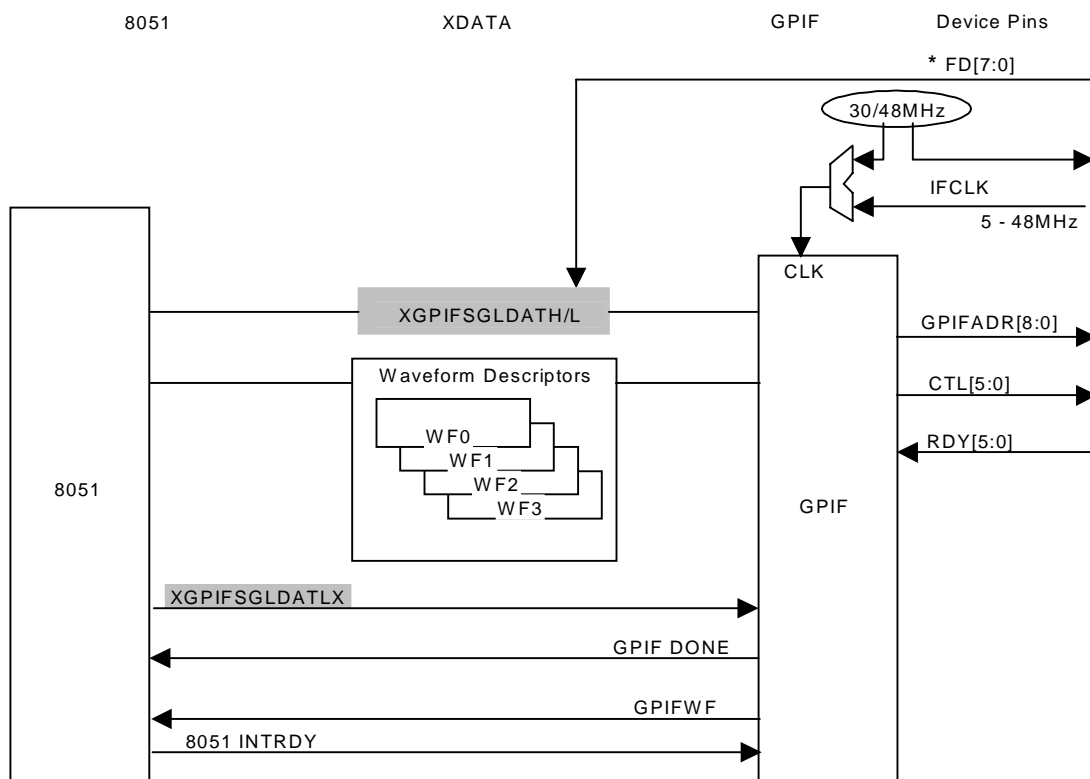

\* All EPx WORDWIDE bits must be cleared to 0 for 8-bit single transactions. If any of the EPx WORDWIDE bits are set to 1, then single transactions will be 16 bits wide.

Figure 10-14. Firmware Launches a Single-Read Waveform, WORDWIDE=0

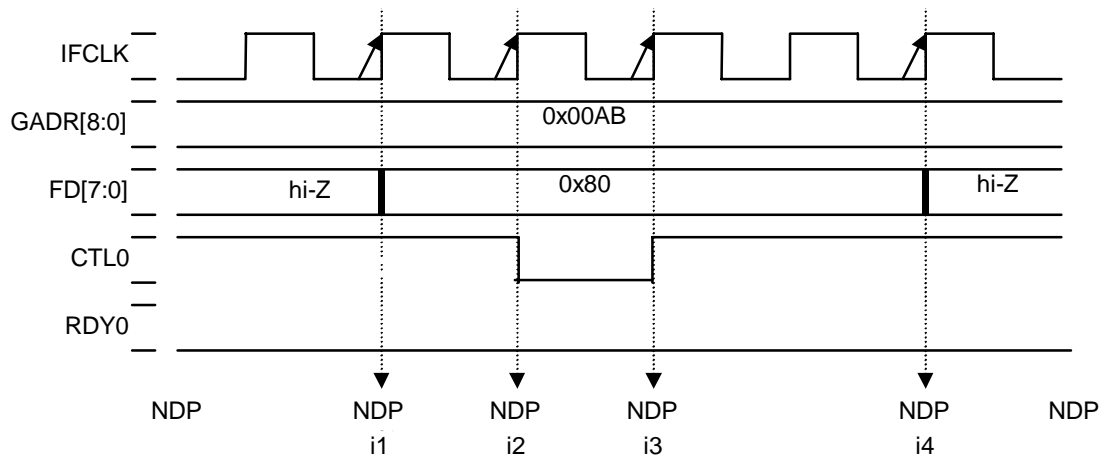

Figure 10-15. Single-Read Transaction Waveform

State	0	1	2	3	4	5	6	7
AddrMode	Same Val	Same Val	Same Val	Same Val	Same Val	Same Val	Same Val	Same Val
DataMode	No Data	No Data	Activate	NO Data	NO Data	NO Data	NO Data	NO Data
NextData	SameData	SameData	SameData	SameData	SameData	SameData	SameData	SameData
Int Trig	No Int	No Int	No Int	No Int	No Int	No Int	No Int	No Int
IF/Wait	Wait 4	Wait 1	Wait 1	Wait 2	Wait 1	Wait 1	Wait 1	
Term A								
LFUNC								
Term B								
Branch1								
Branch0								
Re-execute								
CTL0	1	1	0	1	1	1	1	1
CTL1	1	1	1	1	1	1	1	1
CTL2	1	1	1	1	1	1	1	1
CTL3	1	1	1	1	1	1	1	1
CLT4	1	1	1	1	1	1	1	1
CTL5	1	1	1	1	1	1	1	1

Figure 10-16. GPIFTool Setup for the Waveform of Figure 10-15

To perform a Single-Read transaction:

1. Initialize the GPIF Configuration Registers and Waveform Descriptors.
2. Perform a dummy **read** of the XGPIFSGLDATLX register to start a single transaction.
3. Wait for the GPIF to indicate that the transaction is complete. When the transaction is complete, the DONE bit (GPIFIDLECS.7 or GPIFTRIG.7) will be set to 1. If enabled, a GPIFDONE interrupt will also be generated.
4. Depending on the bus width and the desire to start another transaction, the read data can be retrieved from the XGPIFSGLDATH, XGPIFSGLDATLX, and/or the XGPIFSGLDATLNOX register (or from the SFR-space copies of these registers):

In 16-bit mode **only**, the most significant byte, FD[15:8], of data is read from the XGPIFSGLDATH register.

In 8- and 16-bit modes, the least significant byte of data is read by either:

- reading XGPIFSGLDATLX, which reads the least significant byte and starts another Single-Read transaction.
- reading XGPIFSGLDATLNOX, which reads the least significant byte but does **not** start another Single-Read transaction.

The following C program fragments (Figures 10-17 and 10-18) illustrate how to perform a Single-Read transaction in 8-bit mode (WORDWIDE=0):

```

#define PERIPHCS 0x00AB
#define AOKAY 0x80
#define BURSTMODE 0x0000
#define TRISTATE 0xFFFF
#define EVER ;;

// prototypes
void GpifInit( void );

// Set Address GPIFADR[8:0] to PERIPHERAL
void Peripheral_SetAddress( WORD gaddr )
{
    if( gaddr < 512 )
    { // drive GPIF address bus w/gaddr
        GPIFADRH = gaddr >> 8;
        GPIFADRL = ( BYTE )gaddr; // setup GPIF address
    }
    else
    { // tristate GPIFADR[8:0] pins
        PORTCCFG = 0x00; // [7:0] as port I/O
        OEC = 0x00; // and as inputs
        PORTECFG &= 0x7F; // [8] as port I/O
        OEC &= 0x7F; // and as input
    }
}

// read single byte from PERIPHERAL, using GPIF
void Peripheral_SingleByteRead( BYTE xdata *gdata )
{
    static BYTE g_data = 0x00;

    while( !( GPIFTRIG & 0x80 ) ) // poll GPIFTRIG.7 Done bit
    {
        ;
    }

    // using register(s) in XDATA space, dummy read
    g_data = XGPIFSGLDATLX; // to trigger GPIF single byte read transaction

    while( !( GPIFTRIG & 0x80 ) ) // poll GPIFTRIG.7 Done bit
    {
        ;
    }

    // using register(s) in XDATA space, GPIF read byte from PERIPHERAL here
    *gdata = XGPIFSGLDATLNOX;
}

```

Figure 10-17. Single-Read Transaction Functions

```
void TD_Init( void )
{
    BYTE xdata periph_status;

    ... ..
    GpifInit(); // Configures GPIF from GPIFTool generated waveform data

    // TODO: configure other endpoints, etc. here

    // TODO: arm OUT buffer(s) here

    // setup INT4 as internal source for GPIF interrupts
    // using INT4CLR (SFR), automatically enabled
    //INTSETUP |= 0x03; //Enable INT4 Autovectoring
    //GPIFIE = 0x03; // Enable GPIFDONE and GPIFWF interrupt(s)
    //EIE |= 0x04; // Enable INT4 ISR, EIE.2(EIEX4)=1

    // TODO: configure GPIF interrupt(s) to meet your needs here
    ... ..

    // get status of peripheral function
    Peripheral_SetAddress( PERIPHCS );
    Peripheral_SingleByteRead( &periph_status );

    if( periph_status == AOKAY )
    { // set it and forget it
        Peripheral_SetAddress( BURSTMODE );
    }
    else
    {
        Peripheral_SetAddress( TRISTATE );
        Housekeeping( );
        EZUSB_Discon( TRUE ); // Disconnect from the bus
        for( EVER )
        { // do not xfr peripheral data
            ;
        }
    }
}
```

*Figure 10-18. Initialization Code for Single-Read Transactions*

### 10.4.2 Single-Write Transactions

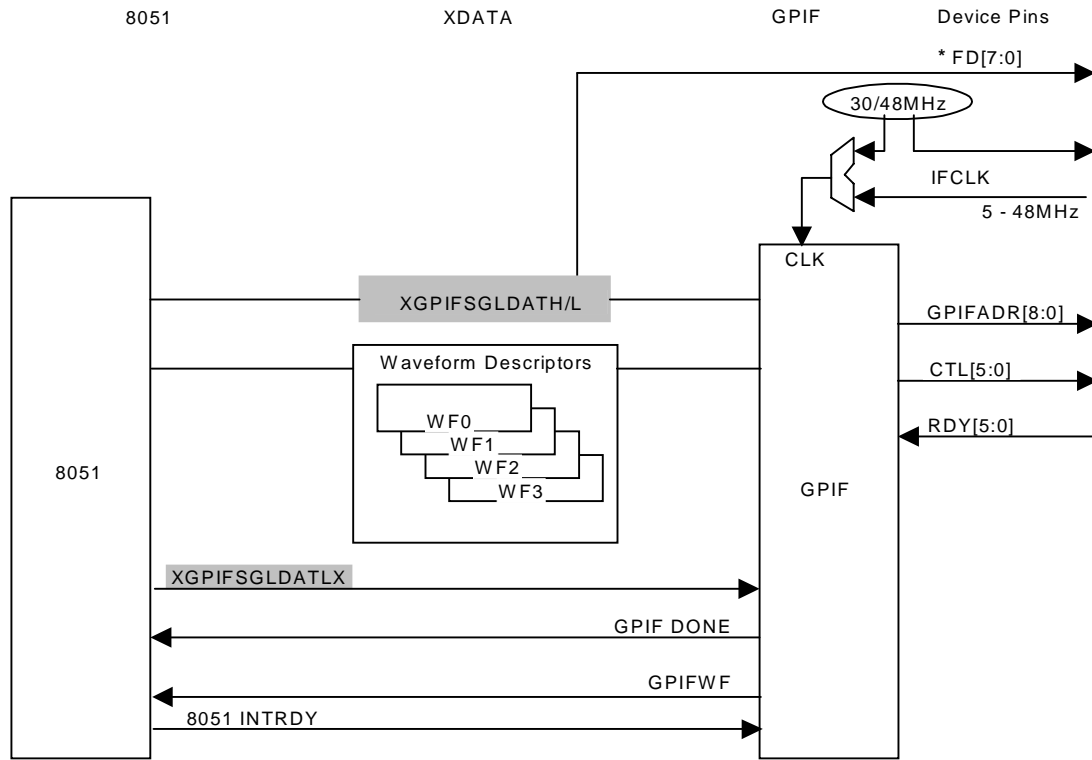

\* All EPx WORDWIDE bits must be cleared to zero for 8-bit single transactions. If any of the EPx WORDWIDE bits are set to 1, then single transactions will be 16 bits wide.

Figure 10-19. Firmware Launches a Single-Write Waveform, WORDWIDE=0



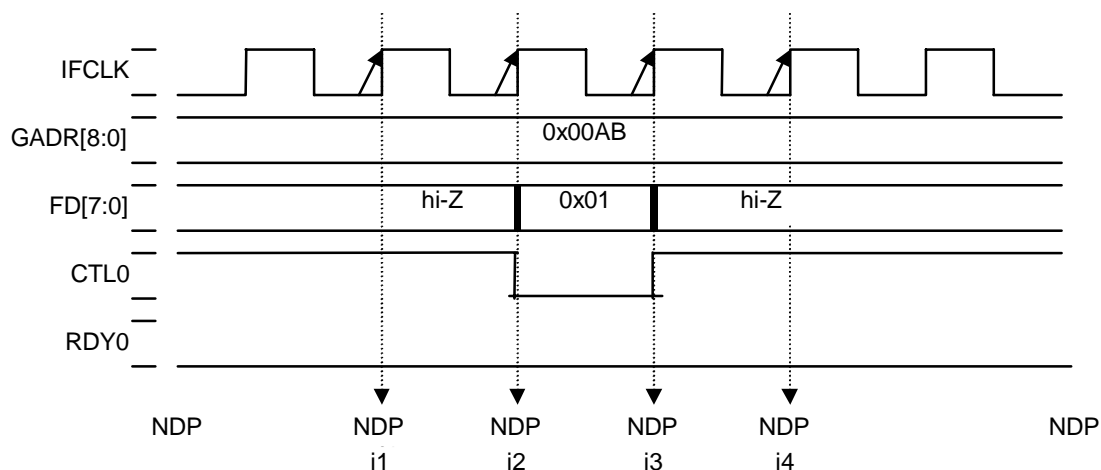

Figure 10-20. Single-Write Transaction Waveform

State	0	1	2	3	4	5	6	7
AddrMode	Same Val	Same Val	Same Val	Same Val	Same Val	Same Val	Same Val	
DataMode	No Data	No Data	Activate	NO Data	NO Data	NO Data	NO Data	
NextData	SameData	SameData	SameData	SameData	SameData	SameData	SameData	
Int Trig	No Int	No Int	No Int	No Int	No Int	No Int	No Int	
IF/Wait	Wait 4	Wait 1	Wait 1	Wait 1	Wait 1	Wait 1	Wait 1	
Term A								
LFUNC								
Term B								
Branch1								
Branch0								
Re-execute								
CTL0	1	1	0	1	1	1	1	1
CTL1	1	1	1	1	1	1	1	1
CTL2	1	1	1	1	1	1	1	1
CTL3	1	1	1	1	1	1	1	1
CLT4	1	1	1	1	1	1	1	1
CTL5	1	1	1	1	1	1	1	1

Figure 10-21. GPIFTool Setup for the Waveform of Figure 10-20

Single-Write transactions are simpler than Single-Read transactions because no dummy-read operation is required. To execute a Single-Write transaction:

1. Initialize the GPIF Configuration Registers and Waveform Descriptors.
2. If in 16-bit mode (`WORDWIDE = 1`), write the most-significant byte of the data to the `XGPIFSGLDATH` register, then **write** the least-significant byte to the `XGPIFSGLDATLX` regis-

ter to start a Single-Write transaction.

In 8-bit mode, simply **write** the data to the XGPIFSGLDATLX register to start a Single-Write transaction.

3. Wait for the GPIF to indicate that the transaction is complete. When the transaction is complete, the DONE bit (GPIFIDLECS.7 or GPIFTRIG.7) will be set to 1. If enabled, a GPIFDONE interrupt will also be generated.

The following C program fragments (Figures 10-22 and 10-23) illustrate how to perform a Single-Write transaction in 8-bit mode (WORDWIDE=0):

```

#define PERIPHCS 0x00AB
#define P_HSMODE 0x01

// prototypes
void GpifInit( void );

// Set Address GPIFADR[8:0] to PERIPHERAL
void Peripheral_SetAddress( WORD gaddr )
{
    GPIFADRH = gaddr >> 8;
    GPIFADRL = ( BYTE )gaddr; // setup GPIF address
}

// write single byte to PERIPHERAL, using GPIF
void Peripheral_SingleByteWrite( BYTE gdata )
{
    while( !( GPIFTRIG & 0x80 ) ) // poll GPIFTRIG.7 Done bit
    {
        ;
    }

    XGPIFSGLDATLX = gdata; // trigger GPIF single byte write transaction
}

```

*Figure 10-22. Single-Write Transaction Functions*

```

void TD_Init( void )
{
    ... ..
    GpifInit(); // Configures GPIF from GPIFTool generated waveform data

    // TODO: configure other endpoints, etc. here

    // TODO: arm OUT buffer(s) here

    // setup INT4 as internal source for GPIF interrupts
    // using INT4CLR (SFR), automatically enabled
    //INTSETUP |= 0x03; //Enable INT4 Autovectoring
    //GPIFIE = 0x03; // Enable GPIFDONE and GPIFWF interrupt(s)
    //EIE |= 0x04; // Enable INT4 ISR, EIE.2(EIEX4)=1

    // TODO: configure GPIF interrupt(s) to meet your needs here
    ... ..

    // tell peripheral we're going into high speed xfr mode
    Peripheral_SetAddress( PERIPHCS );
    Peripheral_SingleByteWrite( P_HSMODE );
}

```

Figure 10-23. Initialization Code for Single-Write Transactions

### 10.4.3 FIFO-Read and FIFO-Write Transactions

FIFO-Read and FIFO-Write waveforms transfer data to and from the FX2's Slave FIFOs (see *Chapter 9 "Slave FIFOs"*). The waveform is started by writing to EPxTRIG, where "x" represents the FIFO (2, 4, 6, or 8) to/from which data should be transferred, or to GPIFTRIG.

A FIFO-Read or FIFO-Write waveform will generally transfer a long stream of data rather than a single byte or word. Usually, the waveform is programmed to terminate when a FIFO flag asserts (e.g., when an IN FIFO is full or an OUT FIFO is empty) or after a specified number of *transactions*. A "transaction" is a transfer of a single byte (if WORDWIDE = 0) or word (if WORDWIDE = 1) to or from a FIFO. Using the *GPIFTool's* terminology, a transaction is either an "Active" or "Next Data".

#### 10.4.3.1 Transaction Counter

To use the Transaction Counter for FIFO "x", load EPxGPIFTCH:L with the desired number of transactions (1 to 65,535; 0 = 65,536). When a FIFO-Read or -Write waveform is triggered on that FIFO, the GPIF will transfer the specified number of bytes (or words, if WORDWIDE = 1) automatically.

This mode of operation is called *Long Transfer Mode*; when the Transaction Counter is used in this way, the Waveform Descriptor should branch to the Idle State after each transaction.

Each time through the Idle State, the GPIF will decrement the Transaction Count; when it expires, the waveform terminates and the DONE bit is set.

Otherwise, the GPIF re-executes the entire Waveform Descriptor. *In Long Transfer Mode, the DONE bit isn't set until the Transaction Count expires.*

While the Transaction Count is active, the GPIF checks the Full Flag (for IN FIFOs) or the Empty Flag (for OUT FIFOs) on every pass through the Idle State. If the flag is asserted, the GPIF pauses until the over/underflow threat is removed, then it automatically resumes. In this way, the GPIF automatically throttles data flow in Long Transfer Mode.

### 10.4.3.2 Reading the Transaction-Count Status in a DP State

To sample the transaction-count status in a DP State, set GPIFREADYCFG.5 to 1 (which instructs the FX2 to replace the RDY5 input with the transaction-count status), then launch a FIFO transaction which uses a transaction count. The FX2 will set RDY5 to 1 when the transaction count expires.

Typically, this feature is used with “re-execute” control tasks; it allows the Transaction Counter to be used without passing through the Idle State after each transaction.

---

### 10.4.4 GPIF Flag Selection

The GPIF can examine the PF, EF, or FF (of the current FIFO) during a waveform. One of the three flags is selected by the FS[1:0] bits in the EPxGPIFFLGSEL register; that selected flag is called the GPIF Flag.

---

### 10.4.5 GPIF Flag Stop

When EPxGPIFFSTOP.0 is set to 1, FIFO-Read and -Write transactions are terminated by the assertion of the GPIF Flag. When this feature is used, it overrides the Transaction Counter; the GPIF waveform terminates (sets DONE to 1) *only* when the GPIF Flag asserts.

No special programming of the Waveform Descriptors is necessary, and FIFO Waveform Descriptors that transition through the Idle State on each transaction (i.e., waveforms that don't use the Transaction Counter) are unaffected. Automatic throttling of the FIFOs in IDLE still occurs, so there's no danger that the GPIF will write to a full FIFO or read from an empty FIFO.



*Unless the firmware aborts the GPIF transfer by writing to the GPIFABORT register, **only** the GPIF Flag assertion will terminate the waveform and set the DONE bit.*

*A waveform can potentially execute forever if the GPIF Flag never asserts.*

***The GPIF Flag is tested only while transitioning through the Idle State, and it isn't latched. If a GPIF Flag assertion occurs in one State, and the next State is a DP which tests the GPIF Flag and waits until it's de-asserted before allowing the state machine to continue to the Idle State, the GPIF will automatically branch back to State 0 as though the GPIF Flag had never been asserted.***

### 10.4.5.1 Performing a FIFO-Read Transaction

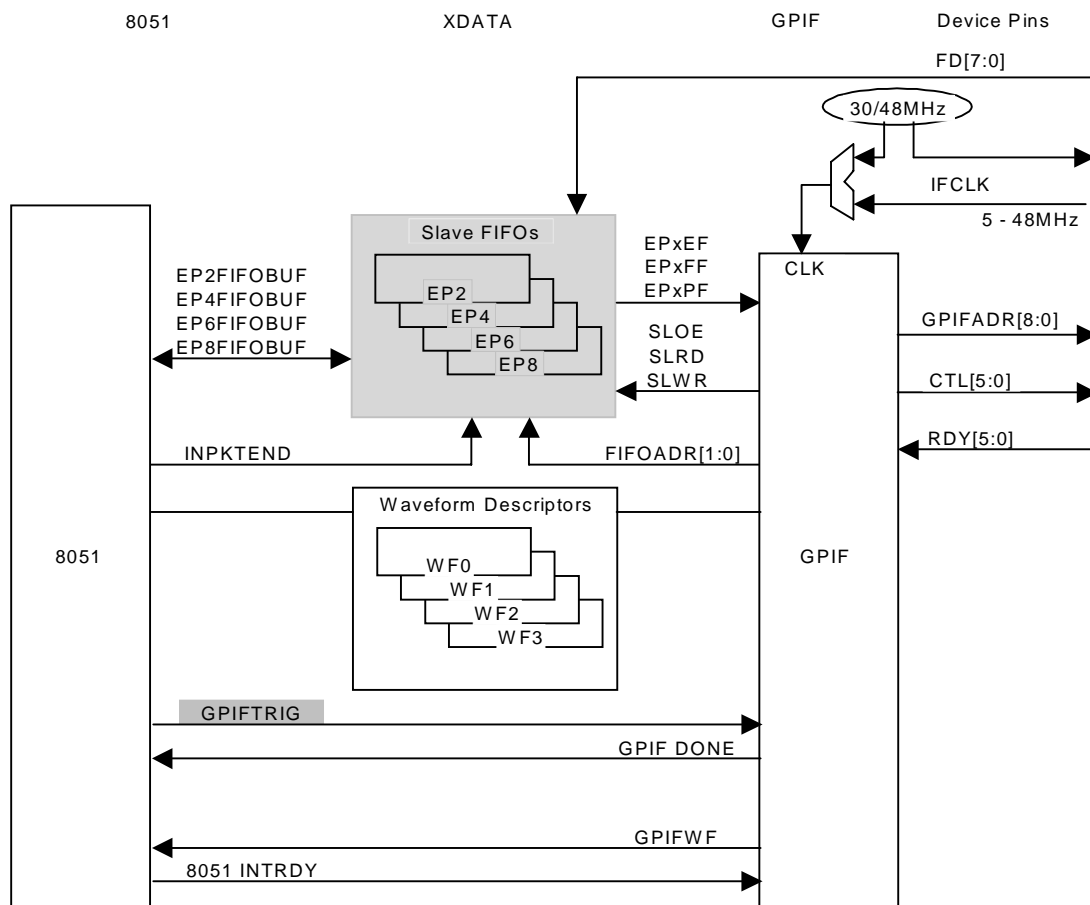

Figure 10-24. Firmware Launches a FIFO-Read Waveform

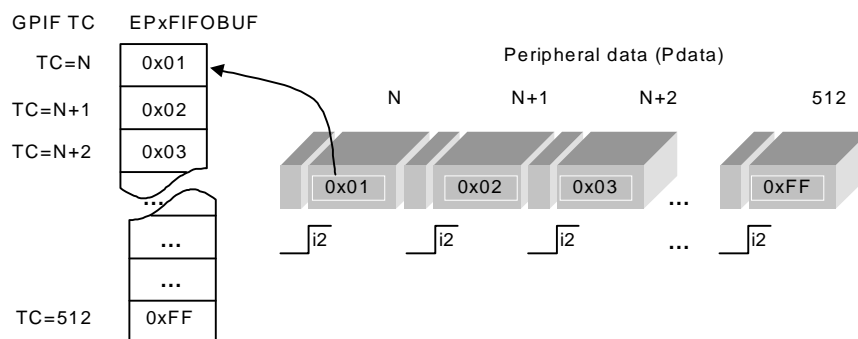

Figure 10-25. Example FIFO-Read Transaction

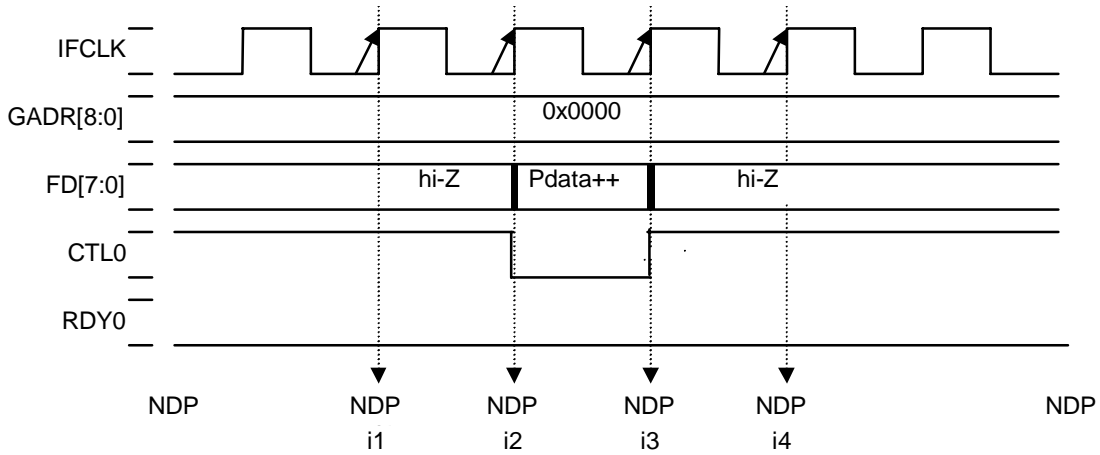

Figure 10-26. FIFO-Read Transaction Waveform

The above waveform executes until the Transaction Counter expires (until it counts to 512, in this example). The Transaction Counter is decremented and sampled on each pass through the Idle State.

Each iteration of the waveform reads a data value from the FIFO Data bus into the FIFO, then decrements and checks the Transaction Counter. When it expires, the DONE bit is set to 1 and the GPIFDONE interrupt request is asserted.

State	0	1	2	3	4	5	6	7
AddrMode	Same Val	Same Val	Same Val	Same Val	Same Val	Same Val	Same Val	
DataMode	No Data	No Data	Activate	NO Data	NO Data	NO Data	NO Data	
NextData	SameData	SameData	SameData	SameData	SameData	SameData	SameData	
Int Trig	No Int	No Int	No Int	No Int	No Int	No Int	No Int	
IF/Wait	Wait 4	Wait 1	Wait 1	Wait 1	Wait 1	Wait 1	Wait 1	
Term A								
LFUNC								
Term B								
Branch1								
Branch0								
Re-execute								
CTL0	1	1	0	1	1	1	1	1
CTL1	1	1	1	1	1	1	1	1
CTL2	1	1	1	1	1	1	1	1
CTL3	1	1	1	1	1	1	1	1
CLT4	1	1	1	1	1	1	1	1
CTL5	1	1	1	1	1	1	1	1

Figure 10-27. GPIFTool Setup for the Waveform of Figure 10-26

Typically, when performing a FIFO Read, only one “Activate” is needed in the waveform, since each execution of “Activate” increments the internal FIFO pointer (and EPxBCH:L) automatically.

To perform a FIFO-Read Transaction:

1. In the GPIFTRIG register, set the RW bit to 1 and load EP1:0 with the appropriate value for the FIFO which is to receive the data.
2. Program the FX2 to detect completion of the transaction. As with all GPIF Transactions, bit 7 of the GPIFTRIG register (the DONE bit) signals when the Transaction is complete.
3. Program the FX2 to commit (“pass-on”) the data from the FIFO to the endpoint. The data can be transferred from the FIFO to the endpoint by either of the following methods:
  - AUTOIN=1: CPU is not in the data path; the FX2 automatically commits data from the FIFO Data bus to the USB.
  - AUTOIN=0: Firmware must manually commit data to the USB by writing either EPxBCL or INPKTEND.

The following C program fragments (Figures 10-28 through 10-31) illustrate how to perform a FIFO-Read transaction in 8-bit mode (WORDWIDE = 0) with AUTOIN = 0:

```

#define GPIFTRIGRD 4

#define GPIF_EP2 0
#define GPIF_EP4 1
#define GPIF_EP6 2
#define GPIF_EP8 3

#define BURSTMODE 0x0000
#define HSPKTSIZE 512

... ..

// read(s) from PERIPHERAL, using GPIF and EPxFIFO
void Peripheral_FIFORead( BYTE FIFO_EpNum )
{
    while( !( GPIFTRIG & 0x80 ) ) // poll GPIFTRIG.7 GPIF Done bit
    {
        ;
    }

    // trigger FIFO read transaction(s), using SFR
    GPIFTRIG = GPIFTRIGRD | FIFO_EpNum; // R/W=1, EP[1:0]=FIFO_EpNum
                                         // for EPx read(s)
}

// Set EP8GPIF Transaction Count
void Peripheral_SetEP8GPIFTC( WORD xfrcnt)
{
    EP8GPIFTCH = xfrcnt >> 8; // setup transaction count
    EP8GPIFTCL = ( BYTE )xfrcnt;
}

... ..

```

*Figure 10-28. FIFO-Read Transaction Functions*



```

void TD_Init( void )
{
    ... ..
    GpifInit(); // Configures GPIF from GPIFTool generated waveform data

    // TODO: configure other endpoints, etc. here
    EP8CFG = 0xE0; // EP8 is DIR=IN, TYPE=BULK
    EP8FIFOCFG = 0x04; // EP8 is AUTOOUT=0, AUTOIN=0, ZEROLEN=1, WORDWIDE=0

    // TODO: arm OUT buffer(s) here

    // setup INT4 as internal source for GPIF interrupts
    // using INT4CLR (SFR), automatically enabled
    //INTSETUP |= 0x03; //Enable INT4 Autovectoring
    //GPIFIE = 0x03; // Enable GPIFDONE and GPIFWF interrupt(s)
    //EIE |= 0x04; // Enable INT4 ISR, EIE.2(EIEX4)=1

    // TODO: configure GPIF interrupt(s) to meet your needs here
    ... ..

    // tell peripheral we're going into high speed xfr mode
    Peripheral_SetAddress( PERIPHCS );
    Peripheral_SingleByteWrite( P_HSMODE );

    // configure some GPIF registers
    Peripheral_SetAddress( BURSTMODE );
    Peripheral_SetEP8GPIFTC( HSPKTSIZE );
}

```

*Figure 10-29. Initialization Code for FIFO-Read Transactions*

```

void TD_Poll( void )
{
    ... ..
    if( ibn_event_flag )
    { // host is asking for EP8 data
        Peripheral_FIFORead( GPIF_EP8 );
        ibn_event_flag = 0;
    }

    if( gpifdone_event_flag )
    { // GPIF currently pointing to EP8, last FIFO accessed
        if( !( EP2468STAT & 0x80 ) )
        { // EP8F=0 when buffer available
            INPKTEND = 0x08; // Firmware commits pkt
                          // by writing #8 to INPKTEND
            gpifdone_event_flag = 0;
        }
    }
    ... ..
}

```

*Figure 10-30. FIFO-Read w/ AUTOIN = 0, Committing Packets via INPKTEND*

```

void TD_Poll( void )
{
  ... ..
  if( !( EP68FIFOFLGS & 0x10 ) )
  { // EP8FF=0 when buffer available
    // host is taking EP8 data fast enough
    Peripheral_FIFORead( GPIF_EP8 );
  }

  if( gpifdone_event_flag )
  { // GPIF currently pointing to EP8, last FIFO accessed
    if( !( EP2468STAT & 0x80 ) )
    { // EP8F=0 when buffer available
      // modify the data
      EP8FIFOBUF[ 0 ] = 0x02; // <STX>, packet start of text msg
      EP8FIFOBUF[ 7 ] = 0x03; // <ETX>, packet end of text msg
      EP8BCH = 0x00;
      EP8BCL = 0x08; // pass buffer on to host
    }
  }
  ... ..
}

```

Figure 10-31. FIFO-Read w/ AUTOIN = 0, Committing Packets via EPxBCL

#### 10.4.6 Firmware Access to IN packet(s), (AUTOIN=1)

The only difference between auto (AUTOIN=1) and manual (AUTOIN=0) modes for IN packet(s) is the packet length feature (EPxAUTOINLENH/L).

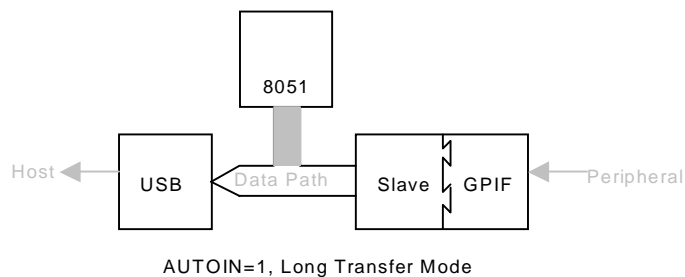

Figure 10-32. AUTOIN=1, GPIF FIFO Read Transactions, AUTOIN = 1

```

TD_Init():

    EP8CFG = 0xE0; // EP8 is DIR=IN, TYPE=BULK
    EP8FIFOCFG = 0x0C; // EP8 is AUTOOUT=0, AUTOIN=1, ZEROLEN=1, WORDWIDE=0
    EP8AUTOINLENH = 0x02; // if AUTOIN=1, auto commit 512 byte packets
    EP8AUTOINLENL = 0x00;

TD_Poll():

    // no code necessary to xfr data from master to host!
    // AUTOIN=1 and EP8AUTOINLEN=512 auto commits packets,
    // in 512 byte chunks.

```

Figure 10-33. FIFO-Read Transaction Code, AUTOIN = 1

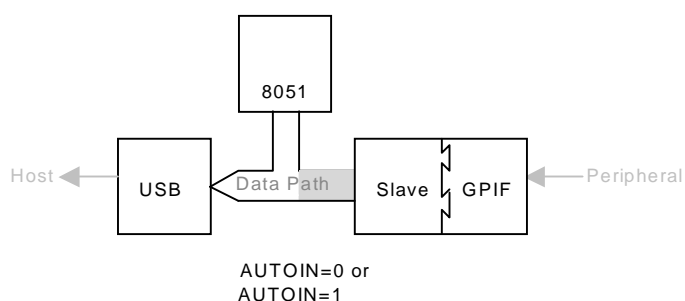

Figure 10-34. Firmware intervention, AUTOIN = 0/1

### 10.4.7 Firmware Access to IN Packet(s), (AUTOIN = 0)

In manual IN mode (AUTOIN=0), the firmware has the following options:

1. It can commit (“pass-on”) packet(s) sent from the master to the host when a buffer is available, either by writing the INPKTEND register with the corresponding EPx number (see Figure 10-35) or by writing to the EPxBCL register (see Figure 10-36).

```

TD_Poll():
... ..
if( master_finished_longxfr( ) )
{ // master currently points to EP8, last FIFO accessed
  if( !( EP68FIFOFLGS & 0x10 ) )
  { // EP8FF=0 when buffer available
    INPKTEND = 0x08; // Firmware commits pkt
                    // by writing #8 to INPKTEND
    release_master( EP8 );
  }
}
... ..

```

*Figure 10-35. Committing a Packet by Writing INPKTEND with EPx Number*

```

TD_Poll():
... ..
if( master_finished_xfr( ) )
{ // modify the data
  EP8FIFOBUF[ 0 ] = 0x02; // <STX>, packet start of text msg
  EP8FIFOBUF[ 7 ] = 0x03; // <ETX>, packet end of text msg
  EP8BCH = 0x00;
  EP8BCL = 0x08; // pass buffer on to host
}
... ..

```

*Figure 10-36. Committing a Packet by Writing to EPxBCL*

2. It can source a packet (i.e., write directly to EPx FIFOBUF) then write the EPxBCL. See Figure 10-37.

```

TD_Poll():
... ..
if( source_pkt_event )
{ // 100msec background timer fired
  if( holdoff_master( ) )
  { // signaled "busy" to master successful
    while( !( EP68FIFOFLGS & 0x20 ) )
    { // EP8EF=0, when buffer not empty
      ; // wait 'til host takes entire FIFO data
    }

    // Reset FIFO 8.

    FIFORESET = 0x80; // Activate NAK-All to avoid race conditions.
    FIFORESET = 0x08; // Reset FIFO 8.
    FIFORESET = 0x00; // Deactivate NAK-All.

    EP8FIFOBUF[ 0 ] = 0x02; // <STX>, packet start of text msg
    EP8FIFOBUF[ 1 ] = 0x06; // <ACK>
    EP8FIFOBUF[ 2 ] = 0x07; // <HEARTBEAT>
    EP8FIFOBUF[ 3 ] = 0x03; // <ETX>, packet end of text msg
    EP8BCH = 0x00;
    EP8BCL = 0x04; // pass src'd buffer on to host
  }
  else
  {
    history_record( EP8, BAD_MASTER );
  }
}
... ..

```

Figure 10-37. Firmware Packet-Sourcing

The firmware has the ability to change the length and contents of IN packet(s). However, *firmware cannot skip IN packets.*

If the firmware modifies the contents of an IN packet it must then write the EPxBCH:L registers to properly commit the “new” IN packet to the host, since writing the INPKTEND register commits the current packet with the number of bytes originally transferred over the FIFO Data bus.

### 10.4.7.1 Performing a FIFO-Write Transaction

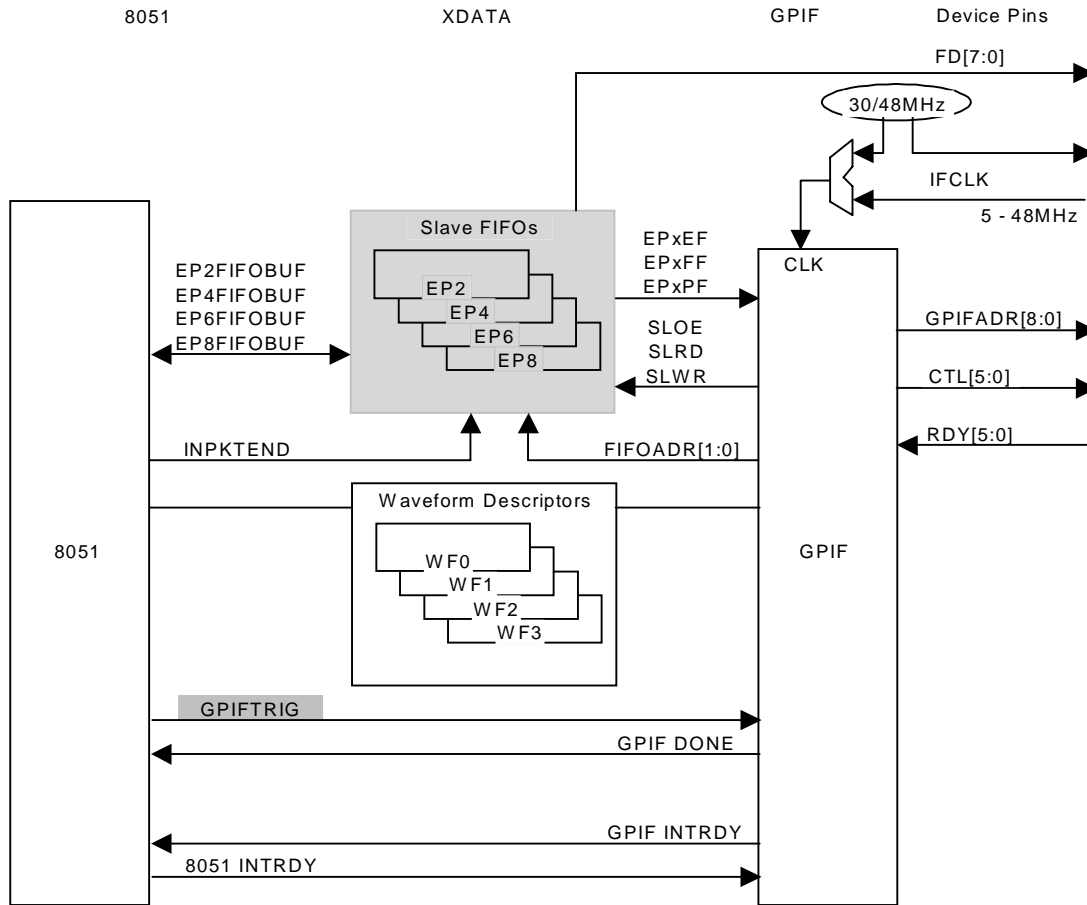

Figure 10-38. Firmware Launches a FIFO-Write Waveform

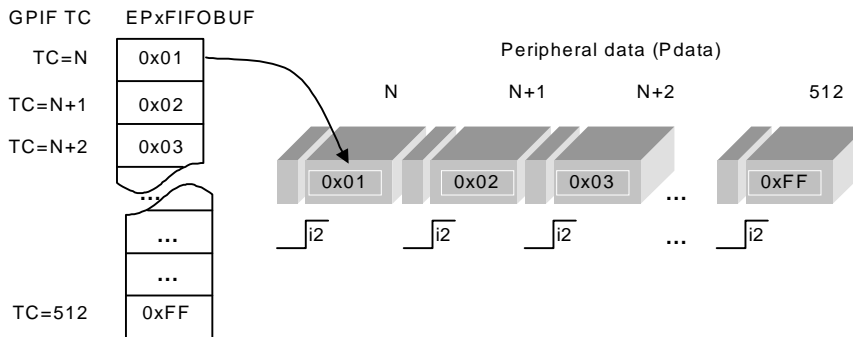

Figure 10-39. Example FIFO-Write Transaction

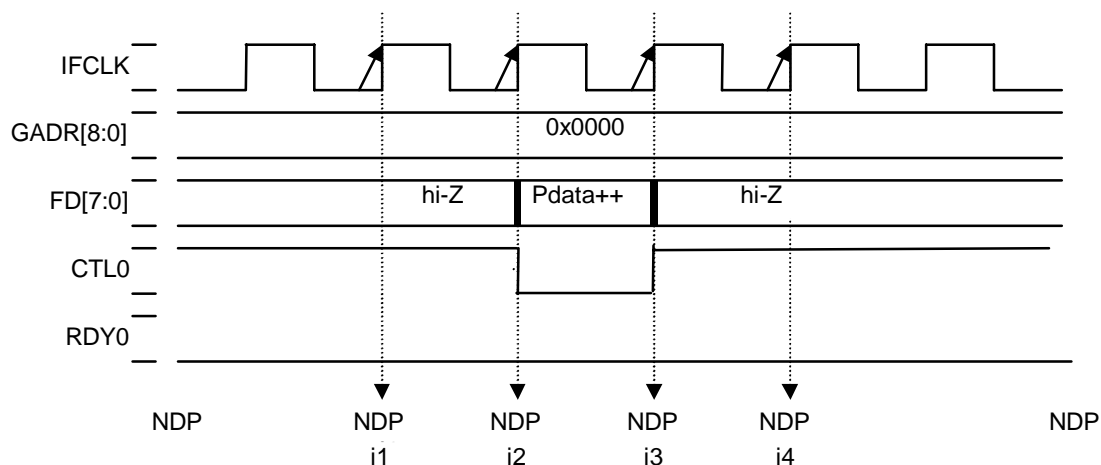

Figure 10-40. FIFO-Write Transaction Waveform

The above waveform executes until the Transaction Counter expires (until it counts to 512, in this example). The Transaction Counter is decremented and sampled on each pass through the Idle State.

Each iteration of the waveform writes a data value from the FIFO to the FIFO Data bus, then decrements and checks the Transaction Counter. When it expires, the DONE bit is set to 1 and the GPIFDONE interrupt request is asserted.

State	0	1	2	3	4	5	6	7
AddrMode	Same Val	Same Val	Same Val	Same Val	Same Val	Same Val	Same Val	Same Val
DataMode	No Data	No Data	Activate	NO Data	NO Data	NO Data	NO Data	NO Data
NextData	SameData	SameData	SameData	SameData	SameData	SameData	NextData	
Int Trig	No Int	No Int	No Int	No Int	No Int	No Int	No Int	No Int
IF/Wait	Wait 4	Wait 1	Wait 1	Wait 1	Wait 1	Wait 1	Wait 1	
Term A								
LFUNC								
Term B								
Branch1								
Branch0								
Re-execute								
CTL0	1	1	0	1	1	1	1	1
CTL1	1	1	1	1	1	1	1	1
CTL2	1	1	1	1	1	1	1	1
CTL3	1	1	1	1	1	1	1	1
CLT4	1	1	1	1	1	1	1	1
CTL5	1	1	1	1	1	1	1	1

Figure 10-41. GPIFTool Setup for the Waveform of Figure 10-40

Typically, when performing a FIFO-Write, only one “NextData” is needed in the waveform, since each execution of “NextData” increments the FIFO pointer.

To perform a FIFO-Write Transaction:

1. In the GPIFTRIG register, set the RW bit to 0 and load EP1:0 with the appropriate value for the FIFO which is to receive the data.
2. Program the FX2 to detect completion of the transaction. As with all GPIF Transactions, bit 7 of the GPIFTRIG register (the DONE bit) signals when the Transaction is complete.
3. Program the FX2 to commit (“pass-on”) the data from the endpoint to the FIFO. The data can be transferred by either of the following methods:
  - AUTOOUT=1: CPU is not in the data path; the FX2 automatically commits data from the USB to the FIFO Data bus.
  - AUTOOUT=0: Firmware must manually commit data to the FIFO Data bus by writing EPxBCL.7=0 (firmware can choose to skip the current packet by writing EPxBCL.7=1).

The following C program fragments (Figures 10-42 through 10-44) illustrate how to perform a FIFO-Read transaction in 8-bit mode (WORDWIDE = 0) with AUTOOUT = 0:

```

#define GPIFTRIGWR 0

#define GPIF_EP2 0
#define GPIF_EP4 1
#define GPIF_EP6 2
#define GPIF_EP8 3

#define BURSTMODE 0x0000
#define HSPKTSIZE 512

... ..

// write byte(s) to PERIPHERAL, using GPIF and EPxFIFO
void Peripheral_FIFOwrite( BYTE FIFO_EpNum )
{
    while( !( GPIFTRIG & 0x80 ) ) // poll GPIFTRIG.7 Done bit
    {
        ;
    }

    // trigger FIFO write transaction(s), using SFR
    GPIFTRIG = FIFO_EpNum; // R/W=0, EP[1:0]=FIFO_EpNum for EPx write(s)
}

// Set EP2GPIF Transaction Count
void Peripheral_SetEP2GPIFTC( WORD xfrcnt)
{
    EP2GPIFTCH = xfrcnt >> 8; // setup transaction count
    EP2GPIFTCL = ( BYTE )xfrcnt;
}

... ..

```

Figure 10-42. FIFO-Write Transaction Functions



```

void TD_Init( void )
{
    ... ..
    GpifInit(); // Configures GPIF from GPIFTool generated waveform data

    // TODO: configure other endpoints, etc. here
    EP2CFG = 0xA2; // EP2 is DIR=OUT, TYPE=BULK, SIZE=512, BUF=2x
    EP2FIFOCFG = 0x00; // EP2 is AUTOOUT=0, AUTOIN=0, ZEROLEN=0, WORDWIDE=0
    // "all" EP2 buffers automatically arm when AUTOOUT=1

    // TODO: arm OUT buffer(s) here
    EP2BCL = 0x80; // write BCL w/skip=1
    EP2BCL = 0x80; // write BCL w/skip=1

    // setup INT4 as internal source for GPIF interrupts
    // using INT4CLR (SFR), automatically enabled
    //INTSETUP |= 0x03; //Enable INT4 Autovectoring
    //GPIFIE = 0x03; // Enable GPIFDONE and GPIFWF interrupt(s)
    //EIE |= 0x04; // Enable INT4 ISR, EIE.2(EIEX4)=1

    // TODO: configure GPIF interrupt(s) to meet your needs here
    ... ..

    // tell peripheral we're going into high speed xfr mode
    Peripheral_SetAddress( PERIPHCS );
    Peripheral_SingleByteWrite( P_HSMODE );

    // configure some GPIF control registers
    Peripheral_SetAddress( BURSTMODE );
    Peripheral_SetEP2GPIFTC( HSPKTSIZE );
}

```

*Figure 10-43. Initialization Code for FIFO-Write Transactions*

```

void TD_Poll( void )
{
    ... ..
    if( !( EP2468STAT & 0x01 ) )
    { // EP2EF=0 when FIFO "not" empty, host sent pkt.
        EP2BCL = 0x00; // SKIP=0, pass buffer on to master

        if( gpifdone_event_flag )
        {
            Peripheral_FIFOwrite( GPIF_EP2 );
            gpifdone_event_flag = 0;
        }
    }
    ... ..
}

```

*Figure 10-44. FIFO-Write w/ AUTOOUT = 0, Committing Packets via EPxBCL*

### 10.4.8 Firmware access to OUT packets, (AUTOOUT=1)

To achieve the maximum USB 2.0 bandwidth, the host and master are directly connected and the CPU is bypassed when AUTOOUT = 1.

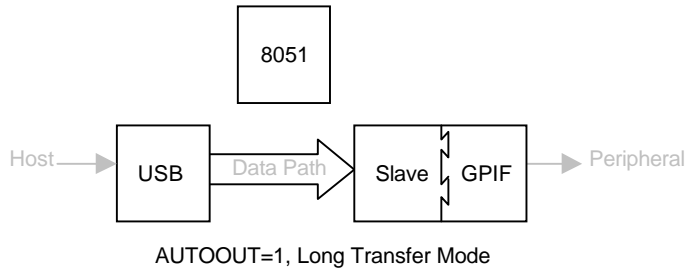

Figure 10-45. CPU not in data path, AUTOOUT=1

The OUT FIFO is automatically committed (“armed”) to the host when AUTOOUT=1:

```

TD_Poll():
... ..
// no code necessary to xfr data from host to master!
// AUTOOUT=1 and SIZE=0 auto commits packets,
// in 512 byte chunks.
... ..
    
```

Figure 10-46. FIFO-Write Transaction Code, AUTOOUT = 1

### 10.4.9 Firmware access to OUT packets, (AUTOOUT = 0)

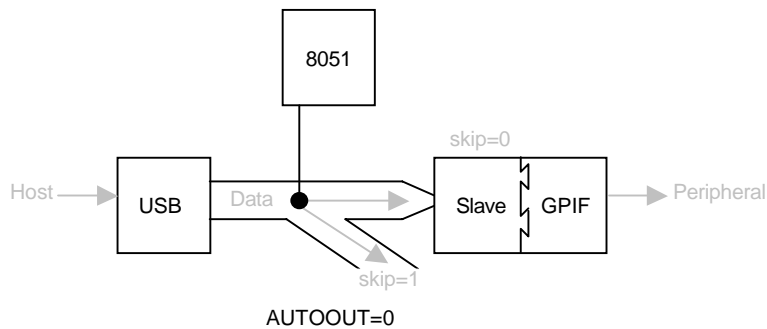

Figure 10-47. Firmware can Skip or Commit, AUTOOUT = 0

```

TD_Init():
... ..
EP2CFG = 0xA2; // EP2 is DIR=OUT, TYPE=BULK, SIZE=512, BUF=2x
EP2FIFOCFG = 0x00; // EP2 is AUTOOUT=0, AUTOIN=0, ZEROLEN=0, WORDWIDE=0
// OUT endpoints do NOT come up armed
EP2BCL = 0x80; // arm first buffer by writing BC w/skip=1
EP2BCL = 0x80; // arm second buffer by writing BC w/skip=1
... ..

```

*Figure 10-48. Initialization Code for AUTOOUT = 0*

In manual OUT mode (AUTOOUT = 0), the firmware has the following options:

1. It can commit (“pass-on”) packet(s) sent from the host to the master when a buffer is available, by writing the EPxBCL register with the SKIP bit (EPxBCL.7) cleared to 0 (see Figure 10-49).

```

TD_Poll():
... ..
if( !( EP24FIFOFLGS & 0x02 ) )
{ // EP2EF=0 when FIFO “not” empty, host sent pkt.
  EP2BCL = 0x00; // SKIP=0, pass buffer on to master
}
... ..

```

*Figure 10-49. Committing an OUT Packet by Writing EPxBCL.7 = 0*

2. It can skip packet(s) sent from the host to the master by writing the EPxBCL register with the SKIP bit (EPxBCL.7) set to 1 (see Figure 10-50).

```

TD_Poll():
... ..
if( !( EP24FIFOFLGS & 0x02 ) )
{ // EP2EF=0 when FIFO “not” empty, host sent pkt.
  EP2BCL = 0x80; // SKIP=1, do NOT pass buffer on to master
}
... ..

```

*Figure 10-50. Skipping an OUT Packet by Writing EPxBCL.7 = 1*

The firmware *cannot* change the length of OUT packets. However, it can modify the contents of OUT packets and choose whether to commit or skip them.

```

TD_Poll():
... ..
if( !( EP24FIFOFLGS & 0x02 ) )
{ // EP2EF=0 when FIFO "not" empty, host sent pkt.
  // modify the data
  EP2FIFOBUF[ 0 ] = 0x02; // <STX>, packet start of text msg
  EP2FIFOBUF[ 9 ] = 0x03; // <ETX>, packet end of text msg
  if( my_foo_pkt_good( EP2FIFOBUF ) )
  {
    EP2BCL = 0x00; // SKIP=0, pass buffer on to master
  }
  else
  {
    EP2BCL = 0x80; // SKIP=1, do NOT pass buffer on to master
  }
}
... ..

```

Figure 10-51. Modifying the Contents of an OUT Packet (AUTOOUT = 0)

The firmware *cannot* source OUT packets.

The master is not notified when a packet has been skipped by the firmware.

The OUT FIFO is not committed to the host during a power-on-reset. In its initialization routine, therefore, the firmware should skip  $n$  packets (where  $n = 2, 3,$  or  $4$  depending on the buffering depth) in order to ensure that the entire FIFO is committed to the host. See Figure 10-52.

```

TD_Init():
... ..
EP2CFG = 0xA2; // EP2 is DIR=OUT, TYPE=BULK, SIZE=512, BUF=2x
EP2FIFOCFG = 0x00; // EP2 is AUTOOUT=0, AUTOIN=0, ZEROLEN=0, WORDWIDE=0
// OUT endpoints do NOT come up armed
EP2BCL = 0x80; // arm first buffer by writing BC w/skip=1
EP2BCL = 0x80; // arm second buffer by writing BC w/skip=1
... ..

```

Figure 10-52. Ensuring that the FIFO is Clear after Power-On-Reset

### 10.4.10 Burst FIFO Transactions

The GPIF can be configured to repeat transactions automatically, with no firmware intervention. These “Burst” transactions (which must always be FIFO-Read or -Write transactions) may be controlled by the Transaction Counter, the GPIF\_PF flag, or the GPIFABORT register.

The following C program fragments (Figures 10-53 through 10-56) illustrate how to perform Burst FIFO-Read transactions using GPIF\_PF in 8-bit mode (WORDWIDE=0) and AUTOIN=0:

```

#define GPIFTRIGRD 4

#define GPIF_EP2 0
#define GPIF_EP4 1
#define GPIF_EP6 2
#define GPIF_EP8 3

#define BURSTMODE 0x0000
#define HSPKTSIZE 512

... ..

// read(s) from PERIPHERAL, using GPIF and EPxFIFO
void Peripheral_FIFORead( BYTE FIFO_EpNum )
{
    while( !( GPIFTRIG & 0x80 ) ) // poll GPIFTRIG.7 GPIF Done bit
    {
        ;
    }

    // trigger FIFO read transaction(s), using SFR
    GPIFTRIG = GPIFTRIGRD | FIFO_EpNum; // R/W=1, EP[1:0]=FIFO_EpNum
                                         // for EPx read(s)
}

// Set EP8GPIF Transaction Count
void Peripheral_SetEP8GPIFTC( WORD xfrcnt)
{
    EP8GPIFTCH = xfrcnt >> 8; // setup transaction count
    EP8GPIFTCL = ( BYTE )xfrcnt;
}

... ..

```

*Figure 10-53. Burst FIFO-Read Transaction Functions*

```

void TD_Init( void )
{
    ... ..
    GpifInit(); // Configures GPIF from GPIFTool generated waveform data

    // TODO: configure other endpoints, etc. here
    EP8CFG = 0xE0; // EP8 is DIR=IN, TYPE=BULK
    EP8FIFOCFG = 0x04; // EP8 is AUTOOUT=0, AUTOIN=0, ZEROLEN=1, WORDWIDE=0

    // TODO: arm OUT buffer(s) here

    // setup INT4 as internal source for GPIF interrupts
    // using INT4CLR (SFR), automatically enabled
    //INTSETUP |= 0x03; //Enable INT4 Autovectoring
    //GPIFIE = 0x03; // Enable GPIFDONE and GPIFWF interrupt(s)
    //EIE |= 0x04; // Enable INT4 ISR, EIE.2(EIEX4)=1

    // TODO: configure GPIF interrupt(s) to meet your needs here
    ... ..

    // tell peripheral we're going into high speed xfr mode
    Peripheral_SetAddress( PERIPHCS );
    Peripheral_SingleByteWrite( P_HSMODE );

    // configure some GPIF registers
    Peripheral_SetAddress( BURSTMODE );
    Peripheral_SetEP8GPIFTC( HSPKTSIZE );
}

```

*Figure 10-54. Initialization for Burst FIFO-Read Transactions*

```
void TD_Poll( void )
{
    ... ..
    if( ibn_event_flag )
    { // host is asking for EP8 data
        Peripheral_FIFORead( GPIF_EP8 );
        ibn_event_flag = 0;
    }

    if( gpifdone_event_flag )
    { // GPIF currently pointing to EP8, last FIFO accessed
        if( !( EP2468STAT & 0x80 ) )
        { // EP8F=0 when buffer available
            INPKTEND = 0x08; // Firmware commits pkt
                          // by writing #8 to INPKTEND
            gpifdone_event_flag = 0;
        }
    }

    // decide how GPIF transitions to DONE for FIFO Transactions
    if( gpif_pf_event_flag )
    {
        EP8GPIFPFSTOP = 0x01; // set bit0=1 to use GPIF_PF
    }
    else
    {
        EP8GPIFPFSTOP = 0x00; // set bit0=0 to use TC
    }
    ... ..
}
```

*Figure 10-55. Burst FIFO-Read Transaction Example, Writing INPKTEND to Commit*

```

void TD_Poll( void )
{
  ... ..
  if( !( EP68FIFOFLGS & 0x10 ) )
  { // EP8FF=0 when buffer available
    // host is taking EP8 data fast enough
    Peripheral_FIFORead( GPIF_EP8 );
  }

  if( gpifdone_event_flag )
  { // GPIF currently pointing to EP8, last FIFO accessed
    if( !( EP2468STAT & 0x80 ) )
    { // EP8F=0 when buffer available
      // modify the data
      EP8FIFOBUF[ 0 ] = 0x02; // <STX>, packet start of text msg
      EP8FIFOBUF[ 7 ] = 0x03; // <ETX>, packet end of text msg
      EP8BCH = 0x00;
      EP8BCL = 0x08; // pass buffer on to host
    }
  }

  // decide how GPIF transitions to DONE for FIFO Transactions
  if( gpif_pf_event_flag )
  {
    EP8GPIFPFSTOP = 0x01; // set bit0=1 to use GPIF_PF
  }
  else
  {
    EP8GPIFPFSTOP = 0x00; // set bit0=0 to use TC
  }
  ... ..
}

```

Figure 10-56. Burst FIFO-Read Transaction Example, Writing EPxBCL to Commit

---

## 10.5 UDMA Interface

---

The FX2 has additional GPIF registers specifically for implementing a UDMA (Ultra-ATA) interface. For more information, please contact the Cypress Semiconductor Applications Department.



## Chapter 11 CPU Introduction

### 11.1 Introduction

The FX2's CPU, an enhanced 8051, is fully described in *Chapter 12, "Instruction Set"*, *Chapter 13, "Input/Output"*, and *Chapter 14, "Timers/Counters and Serial Interface"*. This chapter introduces the processor, its interface to the FX2 logic, and describes architectural differences from a standard 8051. Figure 11-1 is a block diagram of the FX2's 8051-based CPU.

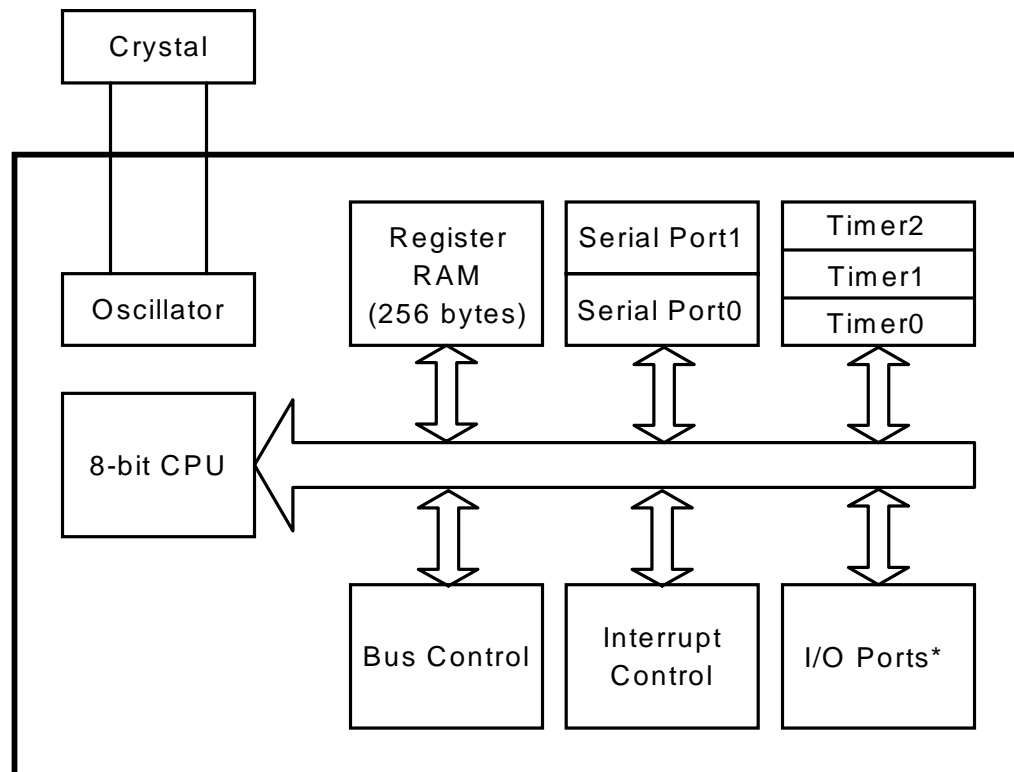

\* The EZ-USB family implements I/O ports differently than in the standard 8051

Figure 11-1. FX2 CPU Features

---

## 11.2 8051 Enhancements

---

The FX2 uses the standard 8051 instruction set, so it's supported by industry-standard 8051 compilers and assemblers. Instructions execute faster on the FX2 than on the standard 8051:

- Wasted bus cycles are eliminated; an instruction cycle uses only four clocks, rather than the standard 8051's 12 clocks.
- The FX2's CPU clock runs at 12MHz, 24MHz, or 48MHz —up to four times the clock speed of the standard 8051.

In addition to speed improvements, the FX2 includes the following architectural enhancements to the CPU:

- A second data pointer
- A second UART
- A third, 16-bit timer (TIMER2)
- A high-speed external memory interface with a non-multiplexed 16-bit address bus
- Eight additional interrupts (INT2-INT6, WAKEUP, T2, and UART1)
- Variable MOVX timing to accommodate fast and slow RAM peripherals
- Two Autopointers (auto-incrementing data pointers)
- Vectored USB and FIFO/GPIF interrupts
- Baud rate timer for 115K/230K baud UART operation
- Sleep mode with three wakeup sources
- An I<sup>2</sup>C-compatible bus controller that runs at 100 or 400 KHz
- FX2-specific SFRs
- Separate buffers for the SETUP and DATA portions of a USB CONTROL transfer
- A hardware pointer for SETUP data, plus logic to process entire CONTROL transfers automatically
- CPU clock-rate selection of 12, 24 or 48MHz
- Breakpoint facility
- I/O Port C read and write strobes

---

## 11.3 Performance Overview

---

The FX2 has been designed to offer increased performance by executing instructions in a 4-clock bus cycle, as opposed to the 12-clock bus cycle in the standard 8051 (see Figure 11-2). This shortened bus timing improves the instruction execution rate for most instructions by a factor of three over the standard 8051 architectures.

Some instructions require a different number of instruction cycles on the FX2 than they do on the standard 8051. In the standard 8051, all instructions except for MUL and DIV take one or two instruction cycles to complete. In the FX2, instructions can take between one and five instruction cycles to complete. However, due to the shortened bus timing of the FX2, every instruction executes faster than on a standard 8051, and the average speed improvement over the entire instruction set is approximately 2.5x. Table 11-1 catalogs the speed improvements.

Table 11-1. FX2 Speed Compared to Standard 8051

<b>Of the 246 FX2 opcodes...</b>
150 execute at 3.0x standard speed
51 execute at 1.5x standard speed
43 execute at 2.0x standard speed
2 execute at 2.4x standard speed
<b>Average Improvement: 2.5x</b>
<b>Note:</b> Comparison is between FX2 and standard 8051 running at the same clock frequency.

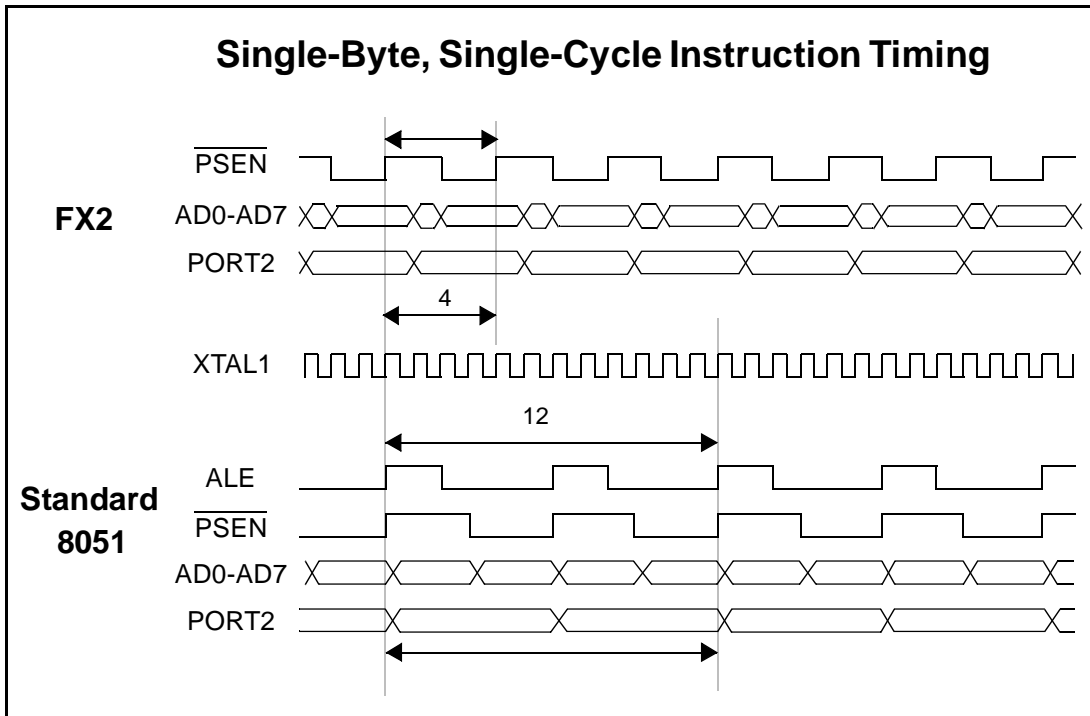

Figure 11-2. FX2 to Standard 8051 Timing Comparison

---

## 11.4 Software Compatibility

---

The FX2 is object-code-compatible with the industry-standard 8051 microcontroller. That is, object code compiled with an industry-standard 8051 compiler or assembler executes on the FX2 and is functionally equivalent. However, because the FX2 uses a different instruction timing than the standard 8051, existing code with timing loops may require modification.

The FX2 instruction timing is identical to that of the Dallas Semiconductor DS80C320.

---

## 11.5 803x/805x Feature Comparison

---

Table 11-2 provides a feature-by-feature comparison between the FX2 and several common 803x/805x devices.

Table 11-2. Comparison Between FX2 and Other 803x/805x Devices

Feature	Intel				Dallas DS80C320	Cypress FX2
	8031	8051	80C32	80C52		
Clocks per instruction cycle	12	12	12	12	4	4
Program / Data Memory	-	4 KB ROM	-	8 KB ROM	-	8 KB RAM
Internal RAM	128 bytes	128 bytes	256 bytes	256 bytes	256 bytes	256 bytes
Data Pointers	1	1	1	1	2	2
Serial Ports	1	1	1	1	2	2
16-bit Timers	2	2	3	3	3	3
Interrupt sources (internal and external)	5	5	6	6	13	13
Stretch data-memory cycles	no	no	no	no	yes	yes

## 11.6 FX2/DS80C320 Differences

Although the FX2 is similar to the DS80C320 in terms of hardware features and instruction cycle timing, there are some important differences between the FX2 and the DS80C320.

### 11.6.1 Serial Ports

The FX2 does not implement serial port framing-error detection and does not implement slave address comparison for multiprocessor communications. Therefore, the FX2 also does not implement the following SFRs: SADDR0, SADDR1, SADEN0, and SADEN1.

### 11.6.2 Timer 2

The FX2 does not implement Timer 2 downcounting mode or the downcount enable bit (TMOD2, Bit 0). Also, the FX2 does not implement Timer 2 output enable (T2OE) bit (TMOD2, Bit 1). Therefore, the TMOD2 SFR is also not implemented in the FX2.

The FX2 Timer 2 overflow output is active for one clock cycle. In the DS80C320, the Timer 2 overflow output is a square wave with a 50% duty cycle.



Although the T2OE bit is not present in the FX2, Timer 2 output can still be enabled or disabled via the PORTECFG.2 bit, since the T2OUT pin is multiplexed with PORTE.2.

*PORTECFG.2=0 configures the pin as a general-purpose I/O pin and disabled Timer 2 output; PORTECFG.2=1 configures the pin as the T2OUT pin and enables Timer 2 output.*

---

### 11.6.3 Timed Access Protection

The FX2 does not implement timed access protection and, therefore, does not implement the TA SFR.

---

### 11.6.4 Watchdog Timer

The FX2 does not implement a watchdog timer.

---

### 11.6.5 Power Fail Detection

The FX2 does not implement a power fail detection circuit.

---

### 11.6.6 Port I/O

The FX2's port I/O implementation is significantly different from that of the DS80C320, mainly because of the alternate functions shared with most of the I/O pins. See *Chapter 13, "Input/Output"*.

---

### 11.6.7 Interrupts

Although the basic interrupt structure of the FX2 is similar to that of the DS80C320, five of the interrupt sources are different:

*Table 11-3. Differences between FX and DS80C320 Interrupts*

Interrupt Priority	Dallas DS80C320	Cypress FX2
0	Power Fail	RESUME (USB Wakeup)
8	External Interrupt 2	USB
9	External Interrupt 3	I <sup>2</sup> C-Compatible Bus
10	External Interrupt 4	GPIF/FIFOs
12	Watchdog Timer	External Interrupt 6

For more information, refer to *Chapter 14, "Timers/Counters and Serial Interface"*.

---

## 11.7 EZ-USB FX2 Register Interface

---

The FX2 peripheral logic (USB, GPIF, FIFOs, etc.) is controlled via a set of memory mapped registers and buffers at addresses 0xE400 through 0xFFFF. These registers and buffers are grouped as follows:

- GPIF Waveform Descriptor Tables
- General configuration
- Endpoint configuration
- Interrupts
- Input/Output
- USB Control
- Endpoint operation
- GPIF/FIFOs
- Endpoint buffers

These registers and their functions are described throughout this manual. A full description of every FX2 register appears in *Chapter 15, "Registers"*

---

## 11.8 EZ-USB FX2 Internal RAM

---

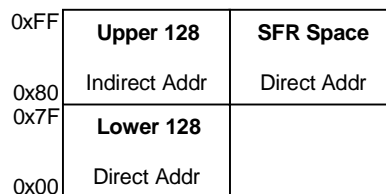

*Figure 11-1. FX2 Internal Data RAM*

Like the standard 8051, the FX2 contains 128 bytes of Internal Data RAM at addresses 0x00-0x7F and a partially populated SFR space at addresses 0x80-0xFF. An additional 128 indirectly-addressed bytes of Internal Data RAM (sometimes called "IDATA") are also available at addresses 0x80-0xFF.

All other on-chip FX2 RAM (program/data memory, endpoint buffer memory, and the FX2 control registers) is addressed as though it were *off-chip* 8051 memory. FX2 firmware reads or writes these bytes as data using the MOVX (“move external”) instruction, even though the FX2 RAM and register set is actually inside the EZ-USB FX2 chip. Off-chip memory attached to the FX2 address and data buses (CY7C68013-128NC only) can also be accessed by the MOVX instruction. FX2 logic encodes its memory strobe and select signals ( $\overline{RD}$ ,  $\overline{WR}$ ,  $\overline{CS}$ ,  $\overline{OE}$ , and  $\overline{PSEN}$ ) to eliminate the need for external logic to separate the on-chip and off-chip memory spaces; see *Chapter 5, “Memory”*.

---

## 11.9 I/O Ports

---

**The FX2 implements I/O ports differently than a standard 8051**, as described in *Chapter 13, “Input/Output”*.

The FX2 has up to five 8-bit wide, bidirectional I/O ports. Each port is associated with a pair of registers:

- An “OEx” register, which sets the input/output direction of each of the 8 port pins (0 = input, 1 = output).
- An “IOx” register. Values written to IOx appear on the pins configured as outputs; values read from IOx indicate the states of the 8 pins, regardless of input/output configuration.

Most I/O pins have alternate functions which are selected using configuration registers. When an alternate configuration is selected for an I/O pin, the corresponding OEx bit is ignored (see *Section 13.2*). The default (power-on reset) state of all I/O ports is: alternate configurations *off*, all I/O pins configured as *inputs*.



## 11.10 Interrupts

All standard 8051 interrupts, plus additional interrupts, are supported by the FX2. Table 11-4 lists the FX2 interrupts.

Table 11-4. EZ-USB FX2 Interrupts

Standard 8051 Interrupts	Additional FX2 Interrupts	Source
INT0		Pin PA0 / INT0
INT1		Pin PA1 / INT1
Timer 0		Internal, Timer 0
Timer 1		Internal, Timer 1
Tx0 & Rx0		Internal, UART0
	INT2	Internal, USB
	INT3	Internal, I <sup>2</sup> C-Compatible Bus Controller
	INT4	Pin INT4 (100- and 128-pin only) <b>OR</b> Internal, GPIF/FIFOs
	INT5	Pin INT5 (100- and 128-pin only)
	INT6	Pin INT6 (100- and 128-pin only)
	WAKEUP	Pin WAKEUP or Pin RA3/WU2
	Tx1 & Rx1	Internal, UART1
	Timer 2	Internal, Timer 2

The FX2 uses INT2 for 27 different USB interrupts. To help determine which interrupt is active, the FX2 provides a feature called Autovectoring, which dynamically changes the address pointed to by the “jump” instruction at the INT2 vector address. This second level of vectoring automatically transfers control to the appropriate USB interrupt service routine (ISR). The FX2 interrupt system, including a full description of the Autovector mechanism, is the subject of *Chapter 4, “Interrupts”*.

## 11.11 Power Control

The FX2 implements a low-power mode that allows it to be used in USB bus-powered devices (which are required by the USB specification to draw no more than 500  $\mu$ A when suspended) and other low-power applications. The mechanism by which the FX2 enters and exits this low-power mode is described in detail in *Chapter 6, “Power Management”*.

## 11.12 Special Function Registers (SFR)

The FX2 was designed to keep coding as standard as possible, to allow easy integration of existing 8051 software development tools. The FX2 SFR registers are summarized in Table 11-5. Standard 8051 SFRs are shown in normal type and FX2-added SFRs are shown in bold type. Full details of the SFRs can be found in *Chapter 15, "Registers"*.

Table 11-5. FX2 Special Function Registers (SFR)

x	8x	9x	Ax	Bx	Cx	Dx	Ex	Fx
0	IOA	IOB	IOC	IOD	SCON1	PSW	ACC	B
1	SP	EXIF	INT2CLR	IOE	SBUF1			
2	DPL0	MPAGE	INT4CLR	OEA				
3	DPH0			OEB				
4	DPL1			OEC				
5	DPH1			OED				
6	DPS			OEE				
7	PCON							
8	TCON	SCON0	IE	IP	T2CON	EICON	EIE	EIP
9	TMOD	SBUF0						
A	TL0	AUTOPTRH1	EP2468STAT	EP01STAT	RCAP2L			
B	TL1	AUTOPTRL1	EP24FIFOFLGS	GPIFTRIG	RCAP2H			
C	TH0	AUTODAT1	EP68FIFOFLGS		TL2			
D	TH1	AUTOPTRH2		GPIFSGLDATH	TH2			
E	CKCON	AUTOPTRL2		GPIFSGLDATLX				
F		AUTODAT2	AUTOPTRSETUP	GPIFSGLDATLNOX				

---

## **11.13 External Address/Data Buses**

---

The 128-pin version of the FX2 provides external, non-multiplexed 16-bit address and 8-bit data buses. This differs from the standard 8051, which multiplexes eight pins among three sources: I/O port 0, the external data bus, and the low byte of the external address bus.

A standard 8051 system with external memory requires a demultiplexing address latch, strobed by the 8051 ALE (Address Latch Enable) pin. The external latch is not required by the FX2 chip, and no ALE signal is provided. In addition to eliminating the need for this external latch, the non-multiplexed FX2 bus saves one cycle per memory-fetch and allows external memory to be connected without sacrificing I/O pins.

The FX2 is the sole master of the bus, providing read and write signals to the off-chip memory. The address bus is output-only, and cannot be floated.

---

## **11.14 Reset**

---

The various FX2 resets and their effects are described in *Chapter 7, "Resets"*.



## Chapter 12 Instruction Set

### 12.1 Introduction

This chapter provides a technical overview and description of the FX2's assembly-language instruction set.

All FX2 instructions are binary-code-compatible with the standard 8051. The FX2 instructions affect bits, flags, and other status functions just as the 8051 instructions do. Instruction timing, however, is different both in terms of the number of clock cycles per instruction cycle and the number of instruction cycles used by each instruction.

Table 12-2 lists the FX2 instruction set and the number of instruction cycles required to complete each instruction. Table 12-1 defines the symbols and mnemonics used in Table 12-2.

*Table 12-1. Legend for Instruction Set Table*

Symbol	Function
A	Accumulator
Rn	Register (R0–R7, in the bank selected by RS1:RS0)
direct	Internal RAM location (0x00 - 0x7F in the “Lower 128”, or 0x80 - 0xFF in “SFR” space)
@Ri	Internal RAM location (0x00 - 0x7F in the “Lower 128”, or 0x80 - 0xFF in the “Upper 128”) pointed to by R0 or R1
rel	Program-memory offset (-128 to +127 bytes relative to the first byte of the following instruction). Used by conditional jumps and SJMP.
bit	Bit address (0x20 - x2F in the “Lower 128,” and SFRs 0x80, 0x88, ..., 0xF0, 0xF8)
#data	8-bit constant (0 - 255)
#data16	16-bit constant (0 - 65535)
addr16	16-bit destination address; used by LCALL and LJMP, which branch anywhere in program memory
addr11	11-bit destination address; used by ACALL and AJMP, which branch only within the current 2K page of program memory (i.e., the upper 5 address bits are copied from the PC)
PC	Program Counter; holds the address of the currently-executing instruction. For the purposes of “ACALL”, “AJMP”, and “MOVC A,@A+PC” instructions, the PC holds the address of the first byte of the instruction <i>following</i> the currently-executing instruction.

Table 12-2. FX2 Instruction Set

Mnemonic	Description	Bytes	Cycles	PSW Flags Affected	Opcode (Hex)
<b>Arithmetic</b>					
ADD A, Rn	Add register to A	1	1	CY OV AC	28-2F
ADD A, direct	Add direct byte to A	2	2	CY OV AC	25
ADD A, @Ri	Add data memory to A	1	1	CY OV AC	26-27
ADD A, #data	Add immediate to A	2	2	CY OV AC	24
ADDC A, Rn	Add register to A with carry	1	1	CY OV AC	38-3F
ADDC A, direct	Add direct byte to A with carry	2	2	CY OV AC	35
ADDC A, @Ri	Add data memory to A with carry	1	1	CY OV AC	36-37
ADDC A, #data	Add immediate to A with carry	2	2	CY OV AC	34
SUBB A, Rn	Subtract register from A with borrow	1	1	CY OV AC	98-9F
SUBB A, direct	Subtract direct byte from A with borrow	2	2	CY OV AC	95
SUBB A, @Ri	Subtract data memory from A with borrow	1	1	CY OV AC	96-97
SUBB A, #data	Subtract immediate from A with borrow	2	2	CY OV AC	94
INC A	Increment A	1	1		04
INC Rn	Increment register	1	1		08-0F
INC direct	Increment direct byte	2	2		05
INC @ Ri	Increment data memory	1	1		06-07
DEC A	Decrement A	1	1		14
DEC Rn	Decrement Register	1	1		18-1F
DEC direct	Decrement direct byte	2	2		15
DEC @Ri	Decrement data memory	1	1		16-17
INC DPTR	Increment data pointer	1	3		A3
MUL AB	Multiply A and B (unsigned; product in B:A)	1	5	CY=0 OV	A4
DIV AB	Divide A by B (unsigned; quotient in A, remainder in B)	1	5	CY=0 OV	84
DA A	Decimal adjust A	1	1	CY	D4
<b>Logical</b>					
ANL, Rn	AND register to A	1	1		58-5F
ANL A, direct	AND direct byte to A	2	2		55
ANL A, @Ri	AND data memory to A	1	1		56-57
ANL A, #data	AND immediate to A	2	2		54
ANL direct, A	AND A to direct byte	2	2		52
ANL direct, #data	AND immediate data to direct byte	3	3		53
ORL A, Rn	OR register to A	1	1		48-4F
ORL A, direct	OR direct byte to A	2	2		45
ORL A, @Ri	OR data memory to A	1	1		46-47
ORL A, #data	OR immediate to A	2	2		44

Table 12-2. FX2 Instruction Set (Continued)

Mnemonic	Description	Bytes	Cycles	PSW Flags Affected	Opcode (Hex)
ORL direct, A	OR A to direct byte	2	2		42
ORL direct, #data	OR immediate data to direct byte	3	3		43
XRL A, Rn	Exclusive-OR register to A	1	1		68-6F
XRL A, direct	Exclusive-OR direct byte to A	2	2		65
XRL A, @Ri	Exclusive-OR data memory to A	1	1		66-67
XRL A, #data	Exclusive-OR immediate to A	2	2		64
XRL direct, A	Exclusive-OR A to direct byte	2	2		62
XRL direct, #data	Exclusive-OR immediate to direct byte	3	3		63
CLR A	Clear A	1	1		E4
CPL A	Complement A	1	1		F4
SWAP A	Swap nibbles of a	1	1		C4
RL A	Rotate A left	1	1		23
RLC A	Rotate A left through carry	1	1	CY	33
RR A	Rotate A right	1	1		03
RRC A	Rotate A right through carry	1	1	CY	13
<b>Data Transfer</b>					
MOV A, Rn	Move register to A	1	1		E8-EF
MOV A, direct	Move direct byte to A	2	2		E5
MOV A, @Ri	Move data byte at Ri to A	1	1		E6-E7
MOV A, #data	Move immediate to A	2	2		74
MOV Rn, A	Move A to register	1	1		F8-FF
MOV Rn, direct	Move direct byte to register	2	2		A8-AF
MOV Rn, #data	Move immediate to register	2	2		78-7F
MOV direct, A	Move A to direct byte	2	2		F5
MOV direct, Rn	Move register to direct byte	2	2		88-8F
MOV direct, direct	Move direct byte to direct byte	3	3		85
MOV direct, @Ri	Move data byte at Ri to direct byte	2	2		86-87
MOV direct, #data	Move immediate to direct byte	3	3		75
MOV @Ri, A	MOV A to data memory at address Ri	1	1		F6-F7
MOV @Ri, direct	Move direct byte to data memory at address Ri	2	2		A6-A7
MOV @Ri, #data	Move immediate to data memory at address Ri	2	2		76-77
MOV DPTR, #data16	Move 16-bit immediate to data pointer	3	3		90
MOVC A, @A+DPTR	Move code byte at address DPTR+A to A	1	3		93
MOVC A, @A+PC	Move code byte at address PC+A to A	1	3		83
MOVX A, @Ri	Move external data at address Ri to A	1	2-9*		E2-E3
MOVX A, @DPTR	Move external data at address DPTR to A	1	2-9*		E0

Table 12-2. FX2 Instruction Set (Continued)

Mnemonic	Description	Bytes	Cycles	PSW Flags Affected	Opcode (Hex)
MOVX @Ri, A	Move A to external data at address Ri	1	2-9*		F2-F3
MOVX @DPTR, A	Move A to external data at address DPTR	1	2-9*		F0
PUSH direct	Push direct byte onto stack	2	2		C0
POP direct	Pop direct byte from stack	2	2		D0
XCH A, Rn	Exchange A and register	1	1		C8-CF
XCH A, direct	Exchange A and direct byte	2	2		C5
XCH A, @Ri	Exchange A and data memory at address Ri	1	1		C6-C7
XCHD A, @Ri	Exchange the low-order nibbles of A and data memory at address Ri	1	1		D6-D7
<i>* Number of cycles is user-selectable. See Section 12.1.2, "Stretch Memory Cycles (Wait States)".</i>					
<b>Boolean</b>					
CLR C	Clear carry	1	1	CY=0	C3
CLR bit	Clear direct bit	2	2		C2
SETB C	Set carry	1	1	CY=1	D3
SETB bit	Set direct bit	2	2		D2
CPL C	Complement carry	1	1	CY	B3
CPL bit	Complement direct bit	2	2		B2
ANL C, bit	AND direct bit to carry	2	2	CY	82
ANL C, /bit	AND inverse of direct bit to carry	2	2	CY	B0
ORL C, bit	OR direct bit to carry	2	2	CY	72
ORL C, /bit	OR inverse of direct bit to carry	2	2	CY	A0
MOV C, bit	Move direct bit to carry	2	2	CY	A2
MOV bit, C	Move carry to direct bit	2	2		92
<b>Branching</b>					
ACALL addr11	Absolute call to subroutine	2	3		11-F1
LCALL addr16	Long call to subroutine	3	4		12
RET	Return from subroutine	1	4		22
RETI	Return from interrupt	1	4		32
AJMP addr11	Absolute jump unconditional	2	3		01-E1
LJMP addr16	Long jump unconditional	3	4		02
SJMP rel	Short jump (relative address)	2	3		80
JC rel	Jump if carry = 1	2	3		40
JNC rel	Jump if carry = 0	2	3		50
JB bit, rel	Jump if direct bit = 1	3	4		20
JNB bit, rel	Jump if direct bit = 0	3	4		30
JBC bit, rel	Jump if direct bit = 1, then clear the bit	3	4		10
JMP @ A+DPTR	Jump indirect to address DPTR+A	1	3		73



Table 12-2. FX2 Instruction Set (Continued)

Mnemonic	Description	Bytes	Cycles	PSW Flags Affected	Opcode (Hex)
JZ rel	Jump if accumulator = 0	2	3		60
JNZ rel	Jump if accumulator is non-zero	2	3		70
CJNE A, direct, rel	Compare A to direct byte; jump if not equal	3	4	CY	B5
CJNE A, #d, rel	Compare A to immediate; jump if not equal	3	4	CY	B4
CJNE Rn, #d, rel	Compare register to immediate; jump if not equal	3	4	CY	B8-BF
CJNE @ Ri, #d, rel	Compare data memory to immediate; jump if not equal	3	4	CY	B6-B7
DJNZ Rn, rel	Decrement register; jump if not zero	2	3		D8-DF
DJNZ direct, rel	Decrement direct byte; jump if not zero	3	4		D5
Miscellaneous					
NOP	No operation	1	1		00
There is an additional reserved opcode (A5) that performs the same function asNOP. All mnemonics are copyright 1980, Intel Corporation.					

### 12.1.1 Instruction Timing

Instruction cycles in the FX2 are 4 clock cycles in length, as opposed to the 12 clock cycles per instruction cycle in the standard 8051. For full details of the instruction-cycle timing differences between the FX2 and the standard 8051, see *Section 11.3, "Performance Overview"*.

In the standard 8051, all instructions except for MUL and DIV take one or two instruction cycles to complete. In the FX2, instructions can take between one and five instruction cycles to complete. For calculating the timing of software loops, etc., use the "Cycles" column from Table 12-2. The "Bytes" column indicates the number of bytes occupied by each instruction.

By default, the FX2's timer/counters run at 12 clock cycles per increment so that timer-based events have the same timing as with the standard 8051. The timers can also be configured to run at 4 clock cycles per increment to take advantage of the higher speed of the FX2's CPU.

### 12.1.2 Stretch Memory Cycles (Wait States)

The FX2 can execute a MOVX instruction in as few as 2 instruction cycles. However, it is sometimes desirable to stretch this value (for example to access slow memory or slow memory-mapped peripherals such as UARTs or LCDs). The FX2's "stretch memory cycle" feature enables FX2 firmware to adjust the speed of *data memory* accesses (program-memory code fetches are not affected).

The three LSBs of the Clock Control Register (CKCON, at SFR location 0x8E) control the stretch value; stretch values between zero and seven may be used. A stretch value of zero adds zero instruction cycles, resulting in MOVX instructions which execute in two instruction cycles. A stretch value of seven adds seven instruction cycles, resulting in MOVX instructions which execute in nine instruction cycles. The stretch value can be changed dynamically under program control.

At power-on-reset, the stretch value defaults to one (three-cycle MOVX); for the fastest data memory access, FX2 software must explicitly set the stretch value to zero. The stretch value affects only data memory access (*not* program memory).

The stretch value affects the width of the read/write strobe and all related timing. Using a higher stretch value results in a wider read/write strobe, which allows the memory or peripheral more time to respond.

Table 12-3 lists the data memory access speeds for stretch values zero through seven. MD2-0 are the three LSBs of the Clock Control Register (CKCON.2-0). The strobe width timing shown is typical.

CPUCS.4:3 sets the basic clock reference for the FX2. These bits can be modified by FX2 firmware at any time. At power-on-reset, CPUCS.4:3 is set to '00' (12 Mhz).

Table 12-3. Data Memory Stretch Values

MD2	MD1	MD0	MOVX Instruction Cycles	Read/Write Strobe Width (Clocks)	Strobe Width @ 12MHz CPUCS.4:3 = 00	Strobe Width @ 24MHz CPUCS.4:3 = 01	Strobe Width @ 48MHz CPUCS.4:3 = 10
0	0	0	2	2	167 ns	83.3 ns	41.7 ns
0	0	1	3 (default)	4	333 ns	167 ns	83.3 ns
0	1	0	4	8	667 ns	333 ns	167 ns
0	1	1	5	12	1000 ns	500 ns	250 ns
1	0	0	6	16	1333 ns	667 ns	333 ns
1	0	1	7	20	1667 ns	833 ns	417 ns
1	1	0	8	24	2000 ns	1000 ns	500 ns
1	1	1	9	28	2333 ns	1167 ns	583 ns

---

### 12.1.3 Dual Data Pointers

The FX2 employs dual data pointers to accelerate data memory block moves. The standard 8051 data pointer (DPTR) is a 16-bit pointer used to address external data RAM or peripherals. The FX2 maintains the standard data pointer as DPTR0 at the standard SFR locations 0x82 (DPL0) and 0x83 (DPH0); it is not necessary to modify existing code to use DPTR0.

The FX2 adds a second data pointer (DPTR1) at SFR locations 0x84 (DPL1) and 0x85 (DPH1). The SEL bit (bit 0 of the DPTR Select Register, DPS, at SFR 0x86), selects the active pointer. When SEL = 0, instructions that use the DPTR will use DPL0:DPH0. When SEL = 1, instructions that use the DPTR will use DPL1:DPH1. No other bits of the DPS SFR are used.

All DPTR-related instructions use the data pointer selected by the SEL Bit. Switching between the two data pointers by toggling the SEL bit relieves FX2 firmware from the burden of saving source and destination addresses when doing a block move; therefore, using dual data pointers provides significantly increased efficiency when moving large blocks of data.

The fastest way to toggle the SEL bit between the two data pointers is via the “INC DPS” instruction, which toggles bit 0 of DPS between 0 and 1.

The SFR locations related to the dual data pointers are:

0x82	DPL0	DPTR0 low byte
0x83	DPH0	DPTR0 high byte
0x84	DPL1	DPTR1 low byte
0x85	DPH1	DPTR1 high byte
0x86	DPS	DPTR Select (Bit 0)

---

### 12.1.4 Special Function Registers

The four SFRs listed below are related to CPU operation and program execution. Except for the Stack Pointer SP, each of the registers is bit addressable.

0x81	SP	Stack Pointer
0xD0	PSW	Program Status Word
0xE0	ACC	Accumulator Register
0xF0	B	B Register

Table 12-4 lists the functions of the PSW bits.

Table 12-4. PSW Register - SFR 0xD0

Bit	Function															
PSW.7	<b>CY</b> - Carry flag. This is the <b>unsigned</b> carry bit. The CY flag is set when an arithmetic operation results in a carry from bit 7 to bit 8, and cleared otherwise. In other words, it acts as a virtual bit 8. The CY flag is cleared on multiplication and division. See the "PSW Flags Affected" column in Table 12-2.															
PSW.6	<b>AC</b> - Auxiliary carry flag. Set to 1 when the last arithmetic operation resulted in a carry into (during addition) or borrow from (during subtraction) the high order nibble, otherwise cleared to 0 by all arithmetic operations. See the "PSW Flags Affected" column in Table 12-2.															
PSW.5	<b>F0</b> - User flag 0. Available to FX2 firmware for general purpose.															
PSW.4 PSW.3	<p><b>RS1</b> - Register bank select bit 1. <b>RS0</b> - Register bank select bit 0.</p> <p>RS1:RS0 select a register bank in internal RAM:</p> <table border="1"> <thead> <tr> <th><u>RS1</u></th> <th><u>RS0</u></th> <th><u>Bank Selected</u></th> </tr> </thead> <tbody> <tr> <td>0</td> <td>0</td> <td>Register bank 0, addresses 0x00-0x07</td> </tr> <tr> <td>0</td> <td>1</td> <td>Register bank 1, addresses 0x08-0x0F</td> </tr> <tr> <td>1</td> <td>0</td> <td>Register bank 2, addresses 0x10-0x17</td> </tr> <tr> <td>1</td> <td>1</td> <td>Register bank 3, addresses 0x18-0x1F</td> </tr> </tbody> </table>	<u>RS1</u>	<u>RS0</u>	<u>Bank Selected</u>	0	0	Register bank 0, addresses 0x00-0x07	0	1	Register bank 1, addresses 0x08-0x0F	1	0	Register bank 2, addresses 0x10-0x17	1	1	Register bank 3, addresses 0x18-0x1F
<u>RS1</u>	<u>RS0</u>	<u>Bank Selected</u>														
0	0	Register bank 0, addresses 0x00-0x07														
0	1	Register bank 1, addresses 0x08-0x0F														
1	0	Register bank 2, addresses 0x10-0x17														
1	1	Register bank 3, addresses 0x18-0x1F														
PSW.2	<b>OV</b> - Overflow flag. This is the <b>signed</b> carry bit. The OV flag is set when a positive sum exceeds 0x7F or a negative sum (in two's complement notation) exceeds 0x80. After a multiply, OV = 1 if the result of the multiply is greater than 0xFF. After a divide, OV = 1 if a divide-by-0 occurred. See the "PSW Flags Affected" column in Table 12-2.															
PSW.1	<b>F1</b> - User flag 1. Available to FX2 firmware for general purpose.															
PSW.0	<b>P</b> - Parity flag. Contains the modulo-2 sum of the 8 bits in the accumulator (i.e., set to 1 when the accumulator contains an odd number of "1" bits, set to 0 when the accumulator contains an even number of "1" bits).															

## Chapter 13 Input/Output

---

### 13.1 Introduction

---

The 56-pin FX2 package provides two input-output systems:

- A set of programmable I/O pins
- A programmable I<sup>2</sup>C-compatible bus controller

The 100- and 128-pin packages additionally provide two programmable USARTs, which are fully described in *Chapter 14, "Timers/Counters and Serial Interface."*

The I/O pins may be configured either for general-purpose I/O or for alternate functions (GPIO address and data; FIFO data; USART, timer, and interrupt signals; etc.). This chapter describes the usage of the pins in the general-purpose configuration, and the methods by which the pins may be configured for alternate functions.

This chapter also provides both the programming information for the I<sup>2</sup>C-compatible interface and the operating details of the EEPROM boot loader. The role of the boot loader is described in *Chapter 3, "Enumeration and ReNumeration™"*.

### 13.2 I/O Ports

---

The FX2's I/O ports are implemented differently than those of a standard 8051.

The FX2 has up to five eight-pin bidirectional I/O ports, labeled A, B, C, D, and E. Individual I/O pins are labeled P<sub>x.n</sub>, where *x* is the port (A, B, C, D, or E) and *n* is the pin number (0 to 7).

The 100- and 128-pin FX2 packages provide all five ports; the 56-pin package provides only ports A, B, and D.

Each port is associated with a pair of registers:

- An OEx register (where  $x$  is A, B, C, D, or E), which sets the input/output direction of each of the 8 pins (0 = input, 1 = output). See Figure 13-2.
- An IOx register (where  $x$  is A, B, C, D, or E). Values written to IOx appear on the pins which are configured as outputs; values read from IOx indicate the states of the 8 pins, regardless of input/output configuration. See Figure 13-3.

Most I/O pins have alternate functions which may be selected using configuration registers (see Tables 13-1 through 13-9). Each alternate function is unidirectional; the FX2 “knows” whether the function is an input or an output, so when an alternate configuration is selected for an I/O pin, the corresponding OEx bit is ignored (see Figures 13-4 and 13-5).

The default (power-on reset) state of all I/O ports is:

- Alternate configurations *off*
- All I/O pins configured as *inputs*

Figure 13-1 shows the basic structure of an FX2 I/O pin.

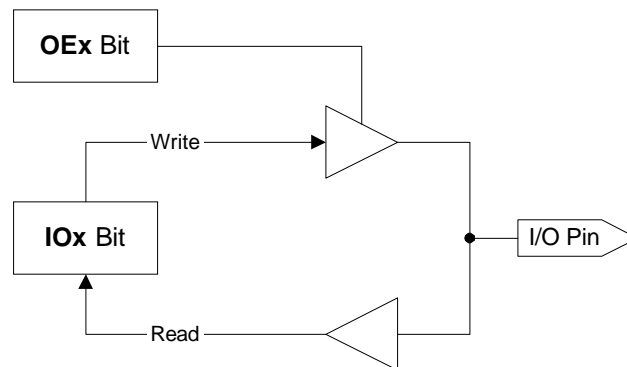

Figure 13-1. FX2 I/O Pin

<b>OEA Port A Output Enable SFR 0xB2</b>							
b7	b6	b5	b4	b3	b2	b1	b0
<b>D7</b>	<b>D6</b>	<b>D5</b>	<b>D4</b>	<b>D3</b>	<b>D2</b>	<b>D1</b>	<b>D0</b>
R/W	R/W	R/W	R/W	R/W	R/W	R/W	R/W
0	0	0	0	0	0	0	0

<b>OEB Port B Output Enable SFR 0xB3</b>							
b7	b6	b5	b4	b3	b2	b1	b0
<b>D7</b>	<b>D6</b>	<b>D5</b>	<b>D4</b>	<b>D3</b>	<b>D2</b>	<b>D1</b>	<b>D0</b>
R/W	R/W	R/W	R/W	R/W	R/W	R/W	R/W
0	0	0	0	0	0	0	0

<b>OEC Port C Output Enable SFR 0xB4</b>							
b7	b6	b5	b4	b3	b2	b1	b0
<b>D7</b>	<b>D6</b>	<b>D5</b>	<b>D4</b>	<b>D3</b>	<b>D2</b>	<b>D1</b>	<b>D0</b>
R/W	R/W	R/W	R/W	R/W	R/W	R/W	R/W
0	0	0	0	0	0	0	0

<b>OED Port D Output Enable SFR 0xB5</b>							
b7	b6	b5	b4	b3	b2	b1	b0
<b>D7</b>	<b>D6</b>	<b>D5</b>	<b>D4</b>	<b>D3</b>	<b>D2</b>	<b>D1</b>	<b>D0</b>
R/W	R/W	R/W	R/W	R/W	R/W	R/W	R/W
0	0	0	0	0	0	0	0

<b>OEE Port E Output Enable SFR 0xB6</b>							
b7	b6	b5	b4	b3	b2	b1	b0
<b>D7</b>	<b>D6</b>	<b>D5</b>	<b>D4</b>	<b>D3</b>	<b>D2</b>	<b>D1</b>	<b>D0</b>
R/W	R/W	R/W	R/W	R/W	R/W	R/W	R/W
0	0	0	0	0	0	0	0

Figure 13-2. I/O Port Output-Enable Registers

<b>IOA Port A (Bit-Addressable) SFR 0x80</b>							
b7	b6	b5	b4	b3	b2	b1	b0
<b>D7</b>	<b>D6</b>	<b>D5</b>	<b>D4</b>	<b>D3</b>	<b>D2</b>	<b>D1</b>	<b>D0</b>
R/W	R/W	R/W	R/W	R/W	R/W	R/W	R/W
x	x	x	x	x	x	x	x

<b>IOB Port B (Bit-Addressable) SFR 0x90</b>							
b7	b6	b5	b4	b3	b2	b1	b0
<b>D7</b>	<b>D6</b>	<b>D5</b>	<b>D4</b>	<b>D3</b>	<b>D2</b>	<b>D1</b>	<b>D0</b>
R/W	R/W	R/W	R/W	R/W	R/W	R/W	R/W
x	x	x	x	x	x	x	x

<b>IOC Port C (Bit-Addressable) SFR 0xA0</b>							
b7	b6	b5	b4	b3	b2	b1	b0
<b>D7</b>	<b>D6</b>	<b>D5</b>	<b>D4</b>	<b>D3</b>	<b>D2</b>	<b>D1</b>	<b>D0</b>
R/W	R/W	R/W	R/W	R/W	R/W	R/W	R/W
x	x	x	x	x	x	x	x

<b>IOD Port D (Bit-Addressable) SFR 0xB0</b>							
b7	b6	b5	b4	b3	b2	b1	b0
<b>D7</b>	<b>D6</b>	<b>D5</b>	<b>D4</b>	<b>D3</b>	<b>D2</b>	<b>D1</b>	<b>D0</b>
R/W	R/W	R/W	R/W	R/W	R/W	R/W	R/W
x	x	x	x	x	x	x	x

<b>IOE Port E SFR 0xB1</b>							
b7	b6	b5	b4	b3	b2	b1	b0
<b>D7</b>	<b>D6</b>	<b>D5</b>	<b>D4</b>	<b>D3</b>	<b>D2</b>	<b>D1</b>	<b>D0</b>
R/W	R/W	R/W	R/W	R/W	R/W	R/W	R/W
x	x	x	x	x	x	x	x

Figure 13-3. I/O Port Data Registers



## 13.3 I/O Port Alternate Functions

Each I/O pin may be configured for an *alternate* (i.e., non-general-purpose I/O) function. These alternate functions are selected through various configuration registers, as described in the following sections.

The I/O-pin logic for alternate-function outputs is slightly different than for alternate-function inputs, as shown in Figures 13-4 (output) and 13-5 (input).

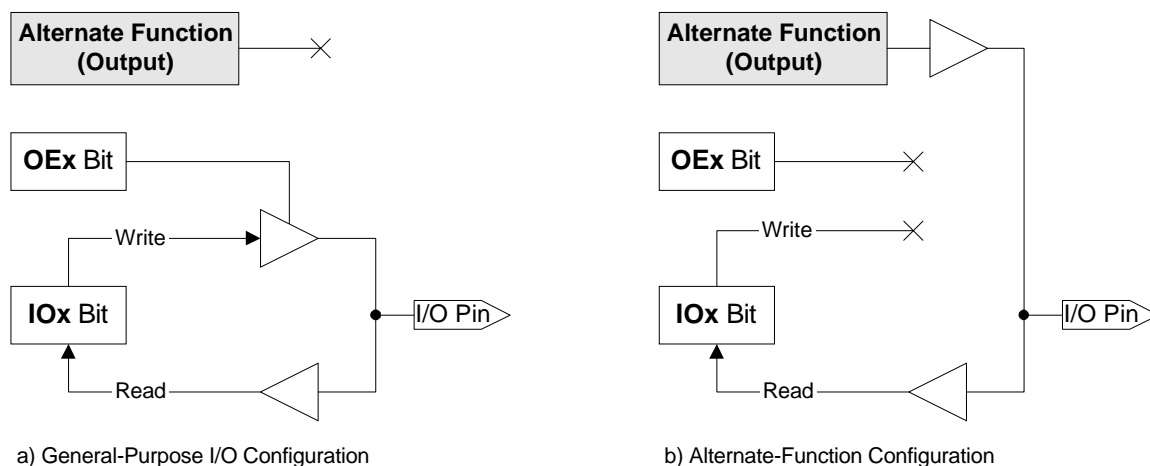

Figure 13-4. I/O-Pin Logic when Alternate Function is an OUTPUT

Figure 13-4 shows an I/O pin whose alternate function is always an *output*.

In Figure 13-4a, the I/O pin is configured for general-purpose I/O. In this configuration, the alternate function is disconnected and the pin functions normally.

In Figure 13-4b, the I/O pin is configured as an alternate-function output. In this configuration, the IOx/OEx output buffer is disconnected from the I/O pin, so writes to IOx and OEx have no effect on the I/O pin. *Reads* from IOx, however, continue to work normally; the state of the I/O pin (and, therefore, the state of the alternate function) is always available.

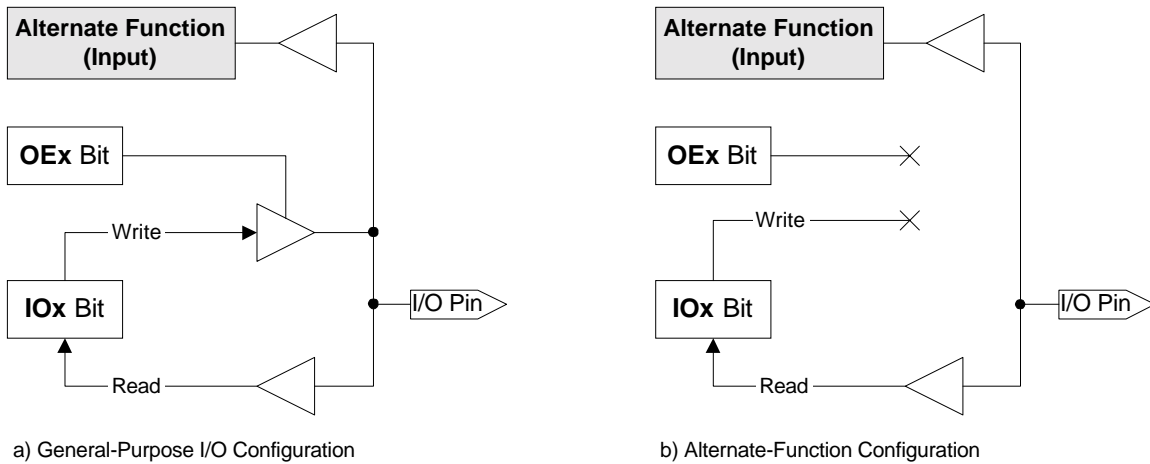

Figure 13-5. I/O-Pin Logic when Alternate Function is an INPUT

Figure 13-5 shows an I/O pin whose alternate function is always an *input*.

In Figure 13-5a, the I/O pin is configured for general-purpose I/O. There's an important difference between alternate-function *inputs* and the alternate-function *outputs* shown earlier in Figure 13-4: *Alternate-function inputs are never disconnected; they're always listening.*

If the alternate function's interrupt is enabled, signals on the I/O pin may trigger that interrupt. If the pin is to be used only for general-purpose I/O, the alternate function's interrupt must be disabled.

For example, suppose the PE5/INT6 pin is configured for general-purpose I/O. Since the INT6 function is an input, the pin signal is also routed to the FX2's internal INT6 logic. If the INT6 interrupt is enabled, traffic on the PE5 pin will trigger an INT6 interrupt. If this is undesirable, the INT6 interrupt should be disabled.

Of course, this side-effect can be useful in certain situations. In the case of PE5/INT6, for example, PE5 can trigger an INT6 interrupt even if the I/O pin is configured as an output (i.e., OEE.5 = 1), so the FX2's firmware can directly generate "external" interrupts.

In Figure 13-5b, the I/O pin is configured as an alternate-function input. Just as with alternate-function outputs, the IOx/OEx output buffer is disconnected from the I/O pin, so writes to IOx and OEx have no effect on the I/O pin. *Reads* from IOx, however, continue to work normally; the state of the I/O pin (and, therefore, the input to the alternate function) is always available.

### 13.3.1 Port A Alternate Functions

Alternate functions for the Port A pins are selected by bits in three registers, as shown in Tables 13-1 and 13-2.

Table 13-1. Register Bits Which Select Port A Alternate Functions

	b7	b6	b5	b4	b3	b2	b1	b0
<b>PORTACFG (0xE670)</b>	<b>FLAGD</b>	<b>SLCS<sup>1</sup></b>	<b>0</b>	<b>0</b>	<b>0</b>	<b>0</b>	<b>INT1</b>	<b>INT0</b>
<b>IFCONFIG (0xE601)</b>	<b>IFCLKSRC</b>	<b>3048MHZ</b>	<b>IFCLKOE</b>	<b>IFCLKPOL</b>	<b>ASYNC</b>	<b>GSTATE</b>	<b>IFCFG1</b>	<b>IFCFG0</b>
<b>WAKEUPCS (0xE682)</b>	<b>WU2</b>	<b>WU</b>	<b>WU2POL</b>	<b>WUPOL</b>	<b>0</b>	<b>DPEN</b>	<b>WU2EN</b>	<b>WUEN</b>

Note 1: Although the SLCS alternate function is selected by bit 6 of PORTACFG, that function does not appear on pin PA6. Instead, the SLCS function appears on pin PA7 (see Table 13-2).

Table 13-2. Port A Alternate-Function Configuration

Port A Pin	Alternate Function	Alternate Function is Selected By...	Alternate Function is Described in...
PA.0	INT0	PORTACFG.0 = 1	Chapter 4
PA.1	INT1	PORTACFG.1 = 1	Chapter 4
PA.2	SLOE	IFCFG1:0 = 11	Chapter 9
PA.3	WU2 <sup>1</sup>	WU2EN = 1	Chapter 6
PA.4	FIFOADR0	IFCFG1:0 = 11	Chapter 9
PA.5	FIFOADR1	IFCFG1:0 = 11	Chapter 9
PA.6	PKTEND	IFCFG1:0 = 11	Chapter 9
PA.7	FLAGD <sup>2</sup>	PORTACFG.7 = 1	Chapter 9
	SLCS <sup>3</sup>	PORTACFG.6 = 1 and IFCFG1:0 = 11	Chapter 9

Note 1: When PA.3 is configured for alternate function WU2, it continues to function as a general-purpose input pin as well. See Section 6.4.1, "WU2 Pin" for more information.

Note 2: Although PA.7's alternate function FLAGD is selected via the PORTACFG register, the state of the FLAGD output is undefined unless IFCFG1:0 = 11.

Note 3: FLAGD takes priority over SLCS if PORTACFG.6 and PORTACFG.7 are both set to 1.

### 13.3.2 Port B and Port D Alternate Functions

When IFCFG1 = 1, all eight Port B pins are configured for an alternate configuration (FIFO Data 7:0).

If any of the FIFOs are set to 16-bit mode (via the WORDWIDE bits in the EPxFIFOCFG registers), all eight Port D pins are also configured for an alternate configuration (FIFO Data 15:8). See Tables 13-3, 13-4, and 13-5.



If **all** WORDWIDE bits are cleared to 0 (i.e., if all four FIFOs are operating in 8-bit mode), the eight Port D pins may be used as general-purpose I/O pins even if IFCFG1 = 1.

Table 13-3. Register Bits Which Select Port B and Port D Alternate Functions

	b7	b6	b5	b4	b3	b2	b1	b0
<b>IFCONFIG (0xE601)</b>	IFCLKSRC	3048MHZ	IFCLKOE	IFCLKPOL	ASYNC	GSTATE	IFCFG1	IFCFG0
<b>EP2FIFOCFG (0xE618)</b>	0	INFM2	OEP2	AUTOOUT	AUTOIN	ZEROLENIN	0	WORDWIDE
<b>EP4FIFOCFG (0xE619)</b>	0	INFM4	OEP4	AUTOOUT	AUTOIN	ZEROLENIN	0	WORDWIDE
<b>EP6FIFOCFG (0xE61A)</b>	0	INFM6	OEP6	AUTOOUT	AUTOIN	ZEROLENIN	0	WORDWIDE
<b>EP8FIFOCFG (0xE61B)</b>	0	INFM8	OEP8	AUTOOUT	AUTOIN	ZEROLENIN	0	WORDWIDE

Table 13-4. Port B Alternate-Function Configuration

Port B Pin	Alternate Function	Alternate Function is Selected By...	Alternate Function is Described in...
PB.7:0	FD[7:0]	IFCFG1 = 1	Chapter 9

Table 13-5. Port D Alternate-Function Configuration

Port D Pin	Alternate Function	Alternate Function is Selected By...	Alternate Function is Described in...
PD.7:0	FD[15:8]	IFCFG1 = 1 and any WORDWIDE bit = 1	Chapter 9

### 13.3.3 Port C Alternate Functions

Each Port C pin may be individually configured for an alternate function by setting a bit in the PORTCCFG register, as shown in Tables 13-6 and 13-7.

Table 13-6. Register Bits Which Select Port C Alternate Functions

	b7	b6	b5	b4	b3	b2	b1	b0
<b>PORTCCFG (0xE671)</b>	<b>GPIFA7</b>	<b>GPIFA6</b>	<b>GPIFA5</b>	<b>GPIFA4</b>	<b>GPIFA3</b>	<b>GPIFA2</b>	<b>GPIFA1</b>	<b>GPIFA0</b>

Table 13-7. Port C Alternate-Function Configuration

Port C Pin	Alternate Function	Alternate Function is Selected By...	Alternate Function is Described in...
PC.0	GPIFA0 <sup>1</sup>	PORTCCFG.0 = 1	Chapter 10
PC.1	GPIFA1 <sup>1</sup>	PORTCCFG.1 = 1	Chapter 10
PC.2	GPIFA2 <sup>1</sup>	PORTCCFG.2 = 1	Chapter 10
PC.3	GPIFA3 <sup>1</sup>	PORTCCFG.3 = 1	Chapter 10
PC.4	GPIFA4 <sup>1</sup>	PORTCCFG.4 = 1	Chapter 10
PC.5	GPIFA5 <sup>1</sup>	PORTCCFG.5 = 1	Chapter 10
PC.6	GPIFA6 <sup>1</sup>	PORTCCFG.6 = 1	Chapter 10
PC.7	GPIFA7 <sup>1</sup>	PORTCCFG.7 = 1	Chapter 10

Note 1: Although the Port C alternate functions GPIFA0:7 are selected via the PORTCCFG register, the states of the GPIFA0:7 outputs are undefined unless IFCFG1:0 = 10.

### 13.3.4 Port E Alternate Functions

Each Port E pin may be individually configured for an alternate function by setting a bit in the PORTECFG register.

If the GSTATE bit in the IFCONFIG register is set to 1, the PE.2:0 pins are automatically configured as GPIF Status pins GSTATE[2:0], regardless of the PORTECFG.2:0 settings. In other words, GSTATE overrides PORTECFG.2:0. See Tables 13-8 and 13-9.

Table 13-8. Register Bits Which Select Port E Alternate Functions

	b7	b6	b5	b4	b3	b2	b1	b0
<b>PORTECFG (0xE671)</b>	<b>GPIFA8</b>	<b>T2EX</b>	<b>INT6</b>	<b>RXD1OUT</b>	<b>RXD0OUT</b>	<b>T2OUT</b>	<b>T1OUT</b>	<b>T0OUT</b>
<b>IFCONFIG (0xE601)</b>	<b>IFCLKSRC</b>	<b>3048MHZ</b>	<b>IFCLKOE</b>	<b>IFCLKPOL</b>	<b>ASYNC</b>	<b>GSTATE</b>	<b>IFCFG1</b>	<b>IFCFG0</b>

Table 13-9. Port E Alternate-Function Configuration

Port E Pin	Alternate Function	Alternate Function is Selected By...	Alternate Function is Described in...
PE.0	T0OUT <sup>1</sup>	PORTECFG.0 = 1 and GSTATE = 0	Chapter 14
PE.1	T1OUT <sup>1</sup>	PORTECFG.1 = 1 and GSTATE = 0	Chapter 14
PE.2	T2OUT <sup>1</sup>	PORTECFG.2 = 1 and GSTATE = 0	Chapter 14
PE.3	RXD0OUT	PORTECFG.3 = 1	Chapter 14
PE.4	RXD1OUT	PORTECFG.4 = 1	Chapter 14
PE.5	INT6	PORTECFG.5 = 1	Chapter 4
PE.6	T2EX	PORTECFG.6 = 1	Chapter 14
PE.7	GPIFA8 <sup>2</sup>	PORTECFG.7 = 1	Chapter 10

Note 1: If GSTATE is set to 1, these settings are overridden and PE.2:0 are all automatically configured as GPIF Status pins (see Chapter 10).

Note 2: Although the PE.7 alternate function GPIFA8 is selected via the PORTECFG register, the state of the GPIFA8 output is undefined unless IFCFG1:0 = 10.

Table 13-10. IFCFG Selection of Port I/O Pin Functions

<b>IFCFG1:0 = 00 (Ports)</b>	<b>IFCFG1:0 = 10 (GPIF Master)</b>	<b>IFCFG1:0 = 11 (Slave FIFO)</b>
PD7	FD[15]	FD[15]
PD6	FD[14]	FD[14]
PD5	FD[13]	FD[13]
PD4	FD[12]	FD[12]
PD3	FD[11]	FD[11]
PD2	FD[10]	FD[10]
PD1	FD[9]	FD[9]
PD0	FD[8]	FD[8]
PB7	FD[7]	FD[7]
PB6	FD[6]	FD[6]
PB5	FD[5]	FD[5]
PB4	FD[4]	FD[4]
PB3	FD[3]	FD[3]
PB2	FD[2]	FD[2]
PB1	FD[1]	FD[1]
PB0	FD[0]	FD[0]
<b>INT0 / PA0</b>	<b>INT0 / PA0</b>	<b>INT0 / PA0</b>
<b>INT1 / PA1</b>	<b>INT1 / PA1</b>	<b>INT1 / PA1</b>
PA2	PA2	SLOE
<b>WU2 / PA3</b>	<b>WU2 / PA3</b>	<b>WU2 / PA3</b>
PA4	PA4	FIFOADR0
PA5	PA5	FIFOADR1
PA6	PA6	FIFOADR2
PA7	PA7	PA7 / FLAGD / $\overline{\text{SLCS}}$
<b>PC7:0</b>	<b>PC7:0</b>	<b>PC7:0</b>
<b>PE7:0</b>	<b>PE7:0</b>	<b>PE7:0</b>

Note: Signals shown in bold type do not change with IFCFG; they are shown for completeness.

## 13.4 I<sup>2</sup>C-Compatible Bus Controller

The I<sup>2</sup>C-compatible bus controller uses the SCL (Serial Clock) and SDA (Serial Data) pins, and performs two functions:

- General-purpose interfacing to I<sup>2</sup>C peripherals
- Boot loading from a serial EEPROM



**Pullup resistors are required on the SDA and SCL lines, even if nothing is connected to the I<sup>2</sup>C-compatible bus. Each line should be pulled up to Vcc through a 2.2K ohm resistor.**

The bus frequency defaults to approximately 100 KHz for compatibility; it can be configured to run four times faster for devices that support the higher speed.

### 13.4.1 Interfacing to I<sup>2</sup>C Peripherals

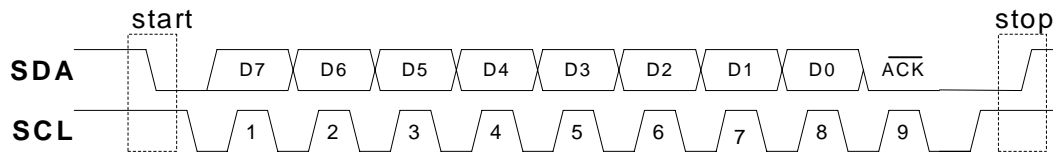

Figure 13-6. General I<sup>2</sup>C Transfer

Figure 13-6 illustrates the waveforms for an I<sup>2</sup>C transfer. SCL and SDA are open-drain FX2 pins, which must be pulled up to Vcc with external resistors. The FX2 is a bus master only, meaning that it synchronizes data transfers by generating clock pulses on SCL. Once the master drives SCL low, external slave devices can hold SCL low to extend clock-cycle times.

To synchronize I<sup>2</sup>C data, serial data (SDA) is permitted to change state only while SCL is low, and must be valid while SCL is high. Two exceptions to this rule are used to generate START and STOP conditions: a START condition is defined as a high-to-low transition on SDA while SCL is high, and a STOP condition is defined as a low-to-high transition on SDA while SCL is high. Data is sent MSB first. During the last bit time (clock #9 in Figure 13-6), the master floats the SDA line to allow the slave to acknowledge the transfer by pulling SDA low.

**Multiple Bus Masters** — *The FX2 acts only as a bus master, never as a slave. Conflicts with a second master can be detected, however, by checking for BERR=1 (see Section 13.4.2.2, "Status Bits").*



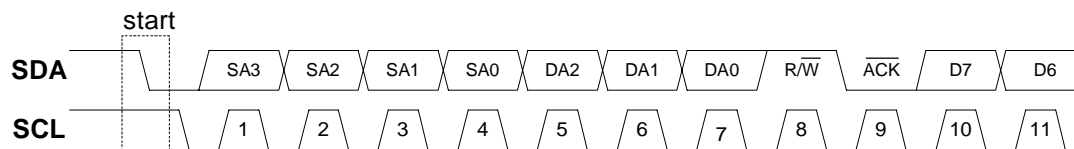

Figure 13-7. Addressing an I<sup>2</sup>C Peripheral

Each peripheral (slave) device on the I<sup>2</sup>C bus has a unique address. The first byte of an I<sup>2</sup>C transaction contains the address of the desired peripheral. Figure 13-7 shows the format for this first byte, which is sometimes called a *control* byte.

The FX2 sends the bit sequence shown in Figure 13-7 to select the peripheral at a particular address, to establish the transfer direction (using  $\overline{R/W}$ ), and to determine if the peripheral is present by testing for ACK.

The four most significant bits (SA3:0) are the peripheral chip's slave address. I<sup>2</sup>C devices are pre-assigned slave addresses by device type. Slave address 1010, for example, is assigned to EEPROMs. The next three bits (DA2:0) usually reflect the states of the peripheral's device address pins. Devices with three address pins can be strapped to allow eight distinct addresses for the same device type, which allows, for example, up to eight identical serial EEPROMs to be individually addressed.

The eighth bit ( $\overline{R/W}$ ) sets the direction for the ensuing data transfer (1 = master read, 0 = master write). Most address transfers are followed by one or more data transfers, with the STOP condition generated after the last data byte is transferred.

In Figure 13-7, a READ transfer follows the address byte (at clock 8, the master sets the  $\overline{R/W}$  bit high, indicating READ). At clock 9, the peripheral device responds to its address by asserting ACK. At clock 10, the master floats SDA and issues SCL pulses to clock in SDA data supplied by the slave.

---

### 13.4.2 Registers

The three registers shown in Figure 13-8 are used to conduct transfers over the I<sup>2</sup>C-compatible bus.

Data is transferred to and from the bus through the I2DAT register. The I2CS register controls the transfers and reports various status conditions. I2CTL configures the bus.

<b>I2CS</b>	<b>I<sup>2</sup>C-Compatible Bus Control and Status</b>						<b>E678</b>
-------------	---	--	--	--	--	--	-------------

b7	b6	b5	b4	b3	b2	b1	b0
<b>START</b>	<b>STOP</b>	<b>LASTRD</b>	<b>ID1</b>	<b>ID0</b>	<b>BERR</b>	<b>ACK</b>	<b>DONE</b>
R/W	R/W	R/W	R	R	R	R	R
0	0	0	x	x	0	0	0

<b>I2DAT</b>	<b>I<sup>2</sup>C-Compatible Bus Data</b>						<b>E679</b>
--------------	---	--	--	--	--	--	-------------

b7	b6	b5	b4	b3	b2	b1	b0
<b>D7</b>	<b>D6</b>	<b>D5</b>	<b>D4</b>	<b>D3</b>	<b>D2</b>	<b>D1</b>	<b>D0</b>
R/W	R/W	R/W	R/W	R/W	R/W	R/W	R/W
x	x	x	x	x	x	x	x

<b>I2CTL</b>	<b>I<sup>2</sup>C-Compatible Bus Mode</b>						<b>E67A</b>
--------------	---	--	--	--	--	--	-------------

b7	b6	b5	b4	b3	b2	b1	b0
<b>0</b>	<b>0</b>	<b>0</b>	<b>0</b>	<b>0</b>	<b>0</b>	<b>STOPE</b>	<b>400KHZ</b>
R	R	R	R	R	R	R/W	R/W
0	0	0	0	0	0	0	0

Figure 13-8. I<sup>2</sup>C-Compatible Registers

### 13.4.2.1 Control Bits

#### **START**

When START = 1, the next write to I2DAT generates the START condition followed by the serialized byte of data in I2DAT. The START bit is automatically cleared to 0 during the ACK interval (clock 9 in Figure 13-6).

#### **STOP**

When STOP = 1, a stop condition is generated. If the bus is idle when the STOP bit is set, the STOP condition is generated immediately; otherwise, the STOP condition is generated after the ACK phase of the current transfer. The STOP bit is automatically cleared after completing the STOP condition.



While the I<sup>2</sup>C-Compatible Bus controller is generating the “stop” condition, it ignores accesses to the I2CS and I2DAT registers. Firmware should therefore check the STOP Bit for zero before writing new data to I2CS or I2DAT.

An interrupt request is available to signal that the STOP condition is complete.

### **LASTRD**

The master reads data by floating the SDA line and issuing clock pulses on the SCL line; after every eight bits, it drives SDA low for one clock to indicate ACK. To signal the last byte of a multi-byte transfer, the master *floats* SDA at ACK time to instruct the slave to stop sending.

When LASTRD = 1, the FX2 will float the SDA line after the next read transfer. The LASTRD bit is automatically cleared at the end of the transfer (at ACK time).



Setting LASTRD does not automatically generate a STOP condition. At the end of a read transfer, the STOP bit should also be set.

### **13.4.2.2 Status Bits**

After a byte transfer, the FX2 updates the three status bits DONE, ACK, and BERR. If no STOP condition was transmitted, they are updated at ACK time; if a STOP condition was transmitted, they are updated after the STOP.

#### **DONE**

The FX2 sets this bit whenever it completes a byte transfer. The FX2 also generates an interrupt request when it sets the DONE bit. The DONE bit is automatically cleared when the I2DAT register is read or written, and the interrupt request bit is automatically cleared whenever the I2CS or I2DAT registers are read or written.

#### **ACK**

Every ninth SCL of a write transfer, the slave indicates reception of the byte by asserting ACK. The FX2 floats SDA during this time, samples the SDA line, and updates the ACK bit with the complement of the detected value. ACK=1 indicates acknowledge, and ACK=0 indicates not-acknowledge. The ACK bit should be ignored for read transfers on the bus.

#### **BERR**

This bit indicates a bus error. BERR=1 indicates that there was bus contention, which results when an outside device drives the bus when it shouldn't, or when another bus master wins arbitration and takes control of the bus. When a bus error is detected, the current transfer is immediately cancelled, the FX2 floats the SCL and SDA lines, and the bus controller is disabled until a STOP con-

dition is detected on the bus. BERR is automatically cleared when the firmware reads or writes the I2DAT register.



*Clearing the BERR bit (by accessing I2DAT) does not automatically re-enable the bus controller. Once a bus error occurs, the bus controller remains disabled until a STOP condition is detected.*

## **ID1, ID0**

These bits are automatically set by the boot loader to indicate the Boot EEPROM's addressing mode. They're normally used only for debug purposes; for full details, see Section 13.5.

---

### **13.4.3 Sending Data**

To send a multiple-byte data record, follow these steps:

1. Set START=1.
2. Write the peripheral address and direction=0 (for write) to I2DAT.
3. Wait for DONE=1\*. If BERR=1 or ACK=0, go to step 7.
4. Load I2DAT with a data byte.
5. Wait for DONE=1\*. If BERR=1 or ACK=0 go to step 7.
6. Repeat steps 4 and 5 for each byte until all bytes have been transferred.
7. Set STOP=1.

\* If INT3 is enabled, each "Wait for DONE=1" step can be interrupt-driven and handled by an interrupt service routine. See *Chapter 4, "Interrupts"* for more details.

---

### **13.4.4 Receiving Data**

To read a multiple-byte data record, follow these steps:

1. Set START=1.
2. Write the peripheral address and direction=1 (for read) to I2DAT.
3. Wait for DONE=1\*. If BERR=1 or ACK=0, terminate by setting STOP=1.
4. Read I2DAT and discard the data. This initiates the first burst of nine SCL pulses to clock in the first byte from the slave.
5. Wait for DONE=1\*. If BERR=1, terminate by setting STOP=1.
6. Read the data from I2DAT. This initiates another read transfer.
7. Repeat steps 5 and 6 for each byte until ready to read the second-to-last byte.
8. Before reading the second-to-last I2DAT byte, set LASTRD=1.
9. Read the data from I2DAT. With LASTRD=1, this initiates the final byte read on the bus.
10. Wait for DONE=1\*. If BERR=1, terminate by setting STOP=1.

11. Set STOP=1.
12. Read the last byte from I2DAT immediately (the next instruction) after setting the STOP bit. This retrieves the last data byte without initiating an extra read transaction (nine more SCL pulses) on the I<sup>2</sup>C-compatible bus.

\* If INT3 is enabled, each “Wait for DONE=1” step can be interrupt-driven and handled by an interrupt service routine. See *Chapter 4, “Interrupts”* for more details.

## 13.5 EEPROM Boot Loader

Whenever the FX2 is taken out of reset via the reset pin, its boot loader checks for the presence of an EEPROM on the I<sup>2</sup>C-compatible bus. If an EEPROM is detected, the loader reads the first EEPROM byte to determine how to enumerate (specifically, whether to supply hard-wired ID information or read the ID from the EEPROM). The various enumeration modes are described in *Chapter 3, “Enumeration and ReNumeration™”*.

The FX2 boot loader supports two I<sup>2</sup>C-compatible EEPROM types:

- EEPROMs with slave address 1010 that use an 8-bit internal address (e.g., 24LC00, 24LC01/B, 24LC02/B).
- EEPROMs with slave address 1010 that use a 16-bit internal address (e.g., 24AA64, 24LC128, 24AA256).

EEPROMs with densities up to 256 bytes require only a single address byte; larger EEPROMs require two address bytes. The FX2 must determine which EEPROM type is connected — one or two address bytes — so that it can properly read the EEPROM.

The FX2 uses the EEPROM device-address pins A2, A1, and A0 to determine whether to send out one or two bytes of address. As shown in Table 13-11, single-byte-address EEPROMs must be strapped to address 000, while double-byte-address EEPROMs must be strapped to address 001.

Table 13-11. Strap Boot EEPROM Address Lines to These Values

Bytes	Example EEPROM	A2	A1	A0
16	24LC00*	N/A	N/A	N/A
128	24LC01	0	0	0
256	24LC02	0	0	0
4K	24LC32	0	0	1
8K	24LC64	0	0	1

\* This EEPROM does not have device-address pins

After determining whether a one- or two-byte-address EEPROM is attached, the FX2 reports its results in the ID1 and ID0 bits, as shown in Table 13-12.

*Table 13-12. Results of Power-On-Reset EEPROM Test*

<b>ID1</b>	<b>ID0</b>	<b>Meaning</b>
0	0	No EEPROM detected
0	1	One-byte-address load EEPROM detected
1	0	Two-byte-address load EEPROM detected
1	1	Not used

Additional EEPROM devices (with slave address of 1010) can be attached to the I<sup>2</sup>C-compatible bus for general-purpose use, as long as they are strapped for device addresses other than 000 or 001.



*The 24LC00 EEPROM is a special case, because it responds to all eight device addresses. If a 24LC00 is used for boot loading, no other EEPROMS with device address 1010 may be used.*

## Chapter 14 Timers/Counters and Serial Interface

---

### 14.1 Introduction

---

The FX2's timer/counters and serial interface are very similar to the standard 8051's, with some differences and enhancements. This chapter provides technical information on configuring and using the timer/counters and serial interface.

---

### 14.2 Timers/Counters

---

The FX2 includes three timer/counters (Timer 0, Timer 1, and Timer 2). Each timer/counter can operate either as a timer with a clock rate based on the FX2's internal clock (CLKOUT) or as an event counter clocked by the T0 pin (Timer 0), T1 pin (Timer 1), or the T2 pin (Timer 2). Timers 1 and 2 may be used for baud clock generation for the serial interface (see Section 14.3 for details of the serial interface).



*The FX2 can be configured to operate at 12, 24, or 48 MHz. In “timer” mode, the timer/counters run at the same speed as the FX2, and they are not affected by the CLKOE and CLKINV configuration bits (CPUCS.1 and CPUCS.2).*

Each timer/counter consists of a 16-bit register that is accessible to software as two SFRs:

- Timer 0 — TH0 and TL0
- Timer 1 — TH1 and TL1
- Timer 2 — TH2 and TL2

## 14.2.1 803x/805x Compatibility

The implementation of the timers/counters is similar to that of the Dallas Semiconductor DS80C320. Table 14-1 summarizes the differences in timer/counter implementation between the Intel 8051, the Dallas Semiconductor DS80C320, and the FX2.

Table 14-1. Timer/Counter Implementation Comparison

Feature	Intel 8051	Dallas DS80C320	FX2
Number of timers	2	3	3
Timer 0/1 overflow available as output signals	No	No	Yes; T0OUT, T1OUT (one CLKOUT pulse)
Timer 2 output enable	n/a	Yes	Yes
Timer 2 down-count enable	n/a	Yes	No
Timer 2 overflow available as output signal	n/a	Yes	Yes; T2OUT (one CLKOUT pulse)

## 14.2.2 Timers 0 and 1

Timers 0 and 1 operate in four modes, as controlled through the TMOD SFR (Table 14-2) and the TCON SFR (Table 14-3). The four modes are:

- 13-bit timer/counter (mode 0)
- 16-bit timer/counter (mode 1)
- 8-bit counter with auto-reload (mode 2)
- Two 8-bit counters (mode 3, Timer 0 only)



### 14.2.2.1 Mode 0, 13-Bit Timer/Counter — Timer 0 and Timer 1

Mode 0 operation is illustrated in Figure 14-1.

In mode 0, the timer is configured as a 13-bit counter that uses bits 0-4 of TL0 (or TL1) and all 8 bits of TH0 (or TH1). The timer enable bit (TR0/TR1) in the TCON SFR starts the timer. The C/ $\bar{T}$  Bit selects the timer/counter clock source: either CLKOUT or the T0/T1 pins.

The timer counts transitions from the selected source as long as the GATE Bit is 0, or the GATE Bit is 1 and the corresponding interrupt pin ( $\overline{INT0}$  or  $\overline{INT1}$ ) is 1.

When the 13-bit count increments from 0x1FFF (all ones), the counter rolls over to all zeros, the TF0 (or TF1) Bit is set in the TCON SFR, and the T0OUT (or T1OUT) pin goes high for one clock cycle.

The upper 3 bits of TL0 (or TL1) are indeterminate in mode 0 and should be ignored.

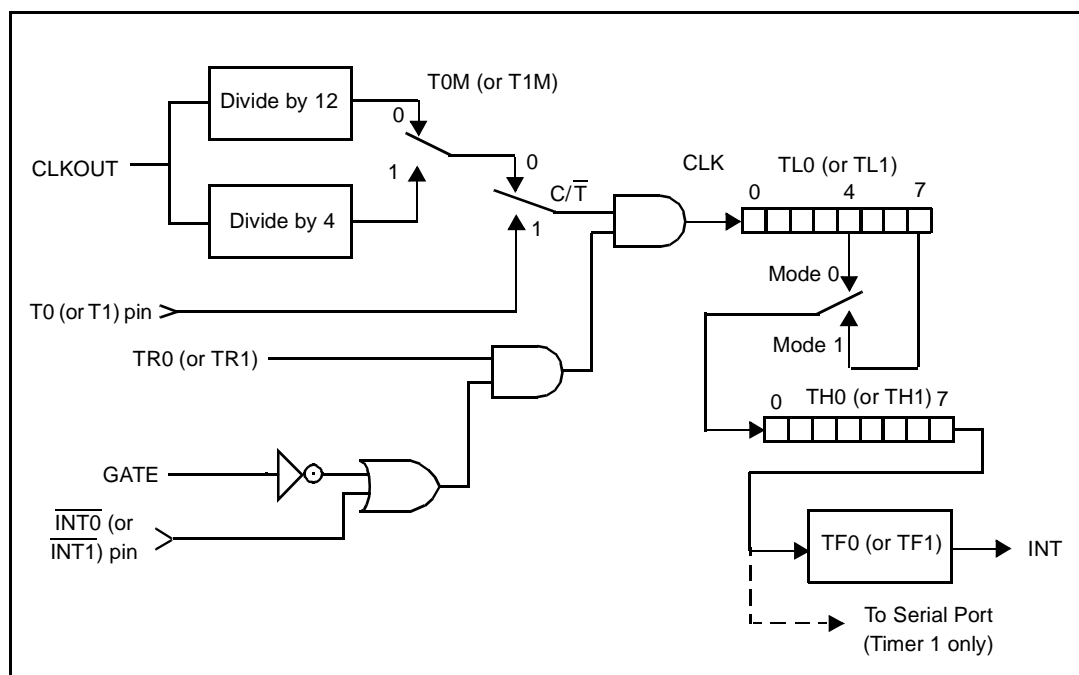

Figure 14-1. Timer 0/1 - Modes 0 and 1

### 14.2.2.2 Mode 1, 16-Bit Timer/Counter — Timer 0 and Timer 1

In mode 1, the timer is configured as a 16-bit counter. As illustrated in Figure 14-1, all 8 bits of the LSB Register (TL0 or TL1) are used. The counter rolls over to all zeros when the count increments from 0xFFFF. Otherwise, mode 1 operation is the same as mode 0.

Table 14-2. TMOD Register — SFR 0x89

Bit	Function															
TMOD.7	<b>GATE1</b> - Timer 1 gate control. When GATE1 = 1, Timer 1 will clock only when $\overline{\text{INT1}} = 1$ and TR1 (TCON.6) = 1. When GATE1 = 0, Timer 1 will clock only when TR1 = 1, regardless of the state of $\overline{\text{INT1}}$ .															
TMOD.6	<b>C/T1</b> - Counter/Timer select. When $\overline{\text{C/T1}} = 0$ , Timer 1 is clocked by CLKOUT/4 or CLKOUT/12, depending on the state of T1M (CKCON.4). When $\overline{\text{C/T1}} = 1$ , Timer 1 is clocked by high-to-low transitions on the T1 pin.															
TMOD.5 TMOD.4	<b>M1</b> - Timer 1 mode select bit 1. <b>M0</b> - Timer 1 mode select bit 0.  <table> <thead> <tr> <th><u>M1</u></th> <th><u>M0</u></th> <th><u>Mode</u></th> </tr> </thead> <tbody> <tr> <td>0</td> <td>0</td> <td>Mode 0 : 13-bit counter</td> </tr> <tr> <td>0</td> <td>1</td> <td>Mode 1 : 16-bit counter</td> </tr> <tr> <td>1</td> <td>0</td> <td>Mode 2 : 8-bit counter with auto-reload</td> </tr> <tr> <td>1</td> <td>1</td> <td>Mode 3 : Timer 1 stopped</td> </tr> </tbody> </table>	<u>M1</u>	<u>M0</u>	<u>Mode</u>	0	0	Mode 0 : 13-bit counter	0	1	Mode 1 : 16-bit counter	1	0	Mode 2 : 8-bit counter with auto-reload	1	1	Mode 3 : Timer 1 stopped
<u>M1</u>	<u>M0</u>	<u>Mode</u>														
0	0	Mode 0 : 13-bit counter														
0	1	Mode 1 : 16-bit counter														
1	0	Mode 2 : 8-bit counter with auto-reload														
1	1	Mode 3 : Timer 1 stopped														
TMOD.3	<b>GATE0</b> - Timer 0 gate control, When GATE0 = 1, Timer 0 will clock only when $\overline{\text{INT0}} = 1$ and TR0 (TCON.4) = 1. When GATE0 = 0, Timer 0 will clock only when TR0 = 1, regardless of the state of $\overline{\text{INT0}}$ .															
TMOD.2	<b>C/T0</b> - Counter/Timer select. When $\overline{\text{C/T0}} = 0$ , Timer 0 is clocked by CLKOUT/4 or CLKOUT/12, depending on the state of T0M (CKCON.3). When $\overline{\text{C/T0}} = 1$ , Timer 0 is clocked by high-to-low transitions on the T0 pin.															
TMOD.1 TMOD.0	<b>M1</b> - Timer 0 mode select bit 1. <b>M0</b> - Timer 0 mode select bit 0.  <table> <thead> <tr> <th><u>M1</u></th> <th><u>M0</u></th> <th><u>Mode</u></th> </tr> </thead> <tbody> <tr> <td>0</td> <td>0</td> <td>Mode 0 : 13-bit counter</td> </tr> <tr> <td>0</td> <td>1</td> <td>Mode 1 : 16-bit counter</td> </tr> <tr> <td>1</td> <td>0</td> <td>Mode 2 : 8-bit counter with auto-reload</td> </tr> <tr> <td>1</td> <td>1</td> <td>Mode 3 : Two 8-bit counters</td> </tr> </tbody> </table>	<u>M1</u>	<u>M0</u>	<u>Mode</u>	0	0	Mode 0 : 13-bit counter	0	1	Mode 1 : 16-bit counter	1	0	Mode 2 : 8-bit counter with auto-reload	1	1	Mode 3 : Two 8-bit counters
<u>M1</u>	<u>M0</u>	<u>Mode</u>														
0	0	Mode 0 : 13-bit counter														
0	1	Mode 1 : 16-bit counter														
1	0	Mode 2 : 8-bit counter with auto-reload														
1	1	Mode 3 : Two 8-bit counters														

Table 14-3. TCON Register — SRF 0x88

Bit	Function
TCON.7	<b>TF1</b> - Timer 1 overflow flag. Set to 1 when the Timer 1 count overflows; automatically cleared when the FX2 vectors to the interrupt service routine.
TCON.6	<b>TR1</b> - Timer 1 run control. 1 = Enable counting on Timer 1.
TCON.5	<b>TF0</b> - Timer 0 overflow flag. Set to 1 when the Timer 0 count overflows; automatically cleared when the FX2 vectors to the interrupt service routine.
TCON.4	<b>TR0</b> - Timer 0 run control. 1 = Enable counting on Timer 0.
TCON.3	<b>IE1</b> - Interrupt 1 edge detect. If external interrupt 1 is configured to be edge-sensitive ( $IT1 = 1$ ), IE1 is set when a negative edge is detected on the $\overline{INT1}$ pin and is automatically cleared when the FX2 vectors to the corresponding interrupt service routine. In this case, IE1 can also be cleared by software. If external interrupt 1 is configured to be level-sensitive ( $IT1 = 0$ ), IE1 is set when the $\overline{INT1}$ pin is 0 and automatically cleared when the $\overline{INT1}$ pin is 1. In level-sensitive mode, software cannot write to IE1.
TCON.2	<b>IT1</b> - Interrupt 1 type select. $\overline{INT1}$ is detected on falling edge when $IT1 = 1$ ; $\overline{INT1}$ is detected as a low level when $IT1 = 0$ .
TCON.1	<b>IE0</b> - Interrupt 0 edge detect. If external interrupt 0 is configured to be edge-sensitive ( $IT0 = 1$ ), IE0 is set when a negative edge is detected on the $\overline{INT0}$ pin and is automatically cleared when the FX2 vectors to the corresponding interrupt service routine. In this case, IE0 can also be cleared by software. If external interrupt 0 is configured to be level-sensitive ( $IT0 = 0$ ), IE0 is set when the $\overline{INT0}$ pin is 0 and automatically cleared when the $\overline{INT0}$ pin is 1. In level-sensitive mode, software cannot write to IE0.
TCON.0	<b>IT0</b> - Interrupt 0 type select. $\overline{INT0}$ is detected on falling edge when $IT0 = 1$ ; $\overline{INT0}$ is detected as a low level when $IT0 = 0$ .

### 14.2.2.3 Mode 2, 8-Bit Counter with Auto-Reload — Timer 0 and Timer 1

In mode 2, the timer is configured as an 8-bit counter, with automatic reload of the start value on overflow. TL0 (or TL1) is the counter, and TH0 (or TH1) stores the reload value.

As illustrated in Figure 14-2, mode 2 counter control is the same as for mode 0 and mode 1. When TL0/1 increments from 0xFF, the value stored in TH0/1 is reloaded into TL0/1.

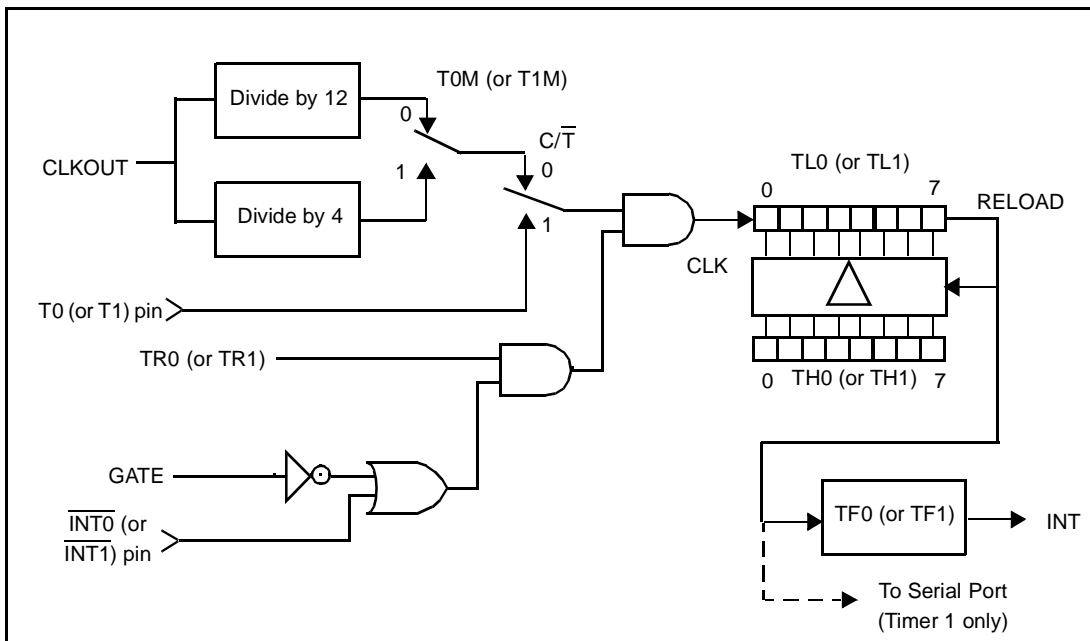

Figure 14-2. Timer 0/1 - Mode 2

#### 14.2.2.4 Mode 3, Two 8-Bit Counters — Timer 0 Only

In mode 3, Timer 0 operates as two 8-bit counters. Selecting mode 3 for Timer 1 simply stops Timer 1.

As shown in Figure 14-3, TL0 is configured as an 8-bit counter controlled by the normal Timer 0 control bits. TL0 can either count CLKOUT cycles (divided by 4 or by 12) or high-to-low transitions on the T0 pin, as determined by the  $C/\bar{T}$  Bit. The GATE function can be used to give counter enable control to the  $\overline{INT0}$  pin.

TH0 functions as an independent 8-bit counter. However, TH0 can only count CLKOUT cycles (divided by 4 or by 12). The Timer 1 control and flag bits (TR1 and TF1) are used as the control and flag bits for TH0.

When Timer 0 is in mode 3, Timer 1 has limited usage because Timer 0 uses the Timer 1 control bit (TR1) and interrupt flag (TF1). Timer 1 can still be used for baud rate generation and the Timer 1 count values are still available in the TL1 and TH1 Registers.

Control of Timer 1 when Timer 0 is in mode 3 is through the Timer 1 mode bits. To turn Timer 1 on, set Timer 1 to mode 0, 1, or 2. To turn Timer 1 off, set it to mode 3. The Timer 1  $C/\bar{T}$  Bit and T1M Bit are still available to Timer 1. Therefore, Timer 1 can count CLKOUT/4, CLKOUT/12, or high-to-low transitions on the T1 pin. The Timer 1 GATE function is also available when Timer 0 is in mode 3.

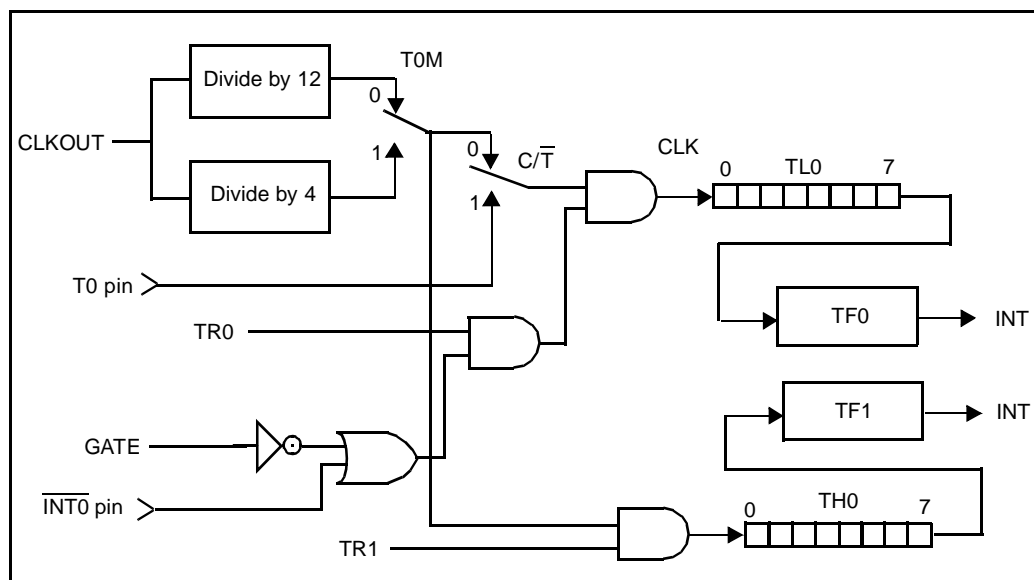

Figure 14-3. Timer 0 - Mode 3

### 14.2.3 Timer Rate Control

By default, the FX2 timers increment every 12 CLKOUT cycles, just as in the standard 8051. Using this default rate allows existing application code with real-time dependencies, such as baud rate, to operate properly.

Applications that require fast timing can set the timers to increment every 4 CLKOUT cycles instead, by setting bits in the Clock Control Register (CKCON) at SFR location 0x8E. (See Table 14-4).

Each timer's rate can be set independently. These settings have no effect in counter mode.

Table 14-4. CKCON (SFR 0x8E) Timer Rate Control Bits

Bit	Function
CKCON.5	<b>T2M</b> - Timer 2 clock select. When T2M = 0, Timer 2 uses CLKOUT/12 (for compatibility with standard 8051); when T2M = 1, Timer 2 uses CLKOUT/4. This bit has no effect when Timer 2 is configured for baud rate generation.
CKCON.4	<b>T1M</b> - Timer 1 clock select. When T1M = 0, Timer 1 uses CLKOUT/12 (for compatibility with standard 8051); when T1M = 1, Timer 1 uses CLKOUT/4.
CKCON.3	<b>T0M</b> - Timer 0 clock select. When T0M = 0, Timer 0 uses CLKOUT/12 (for compatibility with standard 8051); when T0M = 1, Timer 0 uses CLKOUT/4.

---

## 14.2.4 Timer 2

Timer 2 runs only in 16-bit mode and offers several capabilities not available with Timers 0 and 1. The modes available for Timer 2 are:

- 16-bit timer/counter
- 16-bit timer with capture
- 16-bit timer/counter with auto-reload
- Baud rate generator

The SFRs associated with Timer 2 are:

- T2CON (SFR 0xC8) — Timer/Counter 2 Control register, (see Table 14-5).
- RCAP2L (SFR 0xCA) — Used to capture the TL2 value when Timer 2 is configured for capture mode, or as the LSB of the 16-bit reload value when Timer 2 is configured for auto-reload mode.
- RCAP2H (SFR 0xCB) — Used to capture the TH2 value when Timer 2 is configured for capture mode, or as the MSB of the 16-bit reload value when Timer 2 is configured for auto-reload mode.
- TL2 (SFR 0xCC) — Lower 8 bits of the 16-bit count.
- TH2 (SFR 0xCD) — Upper 8 bits of the 16-bit count.

Table 14-5. T2CON Register — SFR 0xC8

Bit	Function
T2CON.7	<b>TF2</b> - Timer 2 overflow flag. Hardware will set TF2 when the Timer 2 overflows from 0xFFFF. TF2 must be cleared to 0 by the software. TF2 will only be set to a 1 if RCLK and TCLK are both cleared to 0. Writing a 1 to TF2 forces a Timer 2 interrupt if enabled.
T2CON.6	<b>EXF2</b> - Timer 2 external flag. Hardware will set EXF2 when a reload or capture is caused by a high-to-low transition on the T2EX pin, and EXEN2 is set. EXF2 must be cleared to 0 by software. Writing a 1 to EXF2 forces a Timer 2 interrupt if enabled.
T2CON.5	<b>RCLK</b> - Receive clock flag. Determines whether Timer 1 or Timer 2 is used for Serial Port 0 timing of received data in serial mode 1 or 3. RCLK=1 selects Timer 2 overflow as the receive clock; RCLK=0 selects Timer 1 overflow as the receive clock.
T2CON.4	<b>TCLK</b> - Transmit clock flag. Determines whether Timer 1 or Timer 2 is used for Serial Port 0 timing of transmit data in serial mode 1 or 3. TCLK=1 selects Timer 2 overflow as the transmit clock; TCLK=0 selects Timer 1 overflow as the transmit clock.
T2CON.3	<b>EXEN2</b> - Timer 2 external enable. EXEN2=1 enables capture or reload to occur as a result of a high-to-low transition on the T2EX pin, if Timer 2 is not generating baud rates for the serial port. EXEN2=0 causes Timer 2 to ignore all external events on the T2EX pin.
T2CON.2	<b>TR2</b> - Timer 2 run control flag. TR2=1 starts Timer 2; TR2=0 stops Timer 2.
T2CON.1	<b>C/T<math>\bar{2}</math></b> - Counter/Timer select. When C/T $\bar{2}$ = 1, Timer 2 is clocked by high-to-low transitions on the T2 pin. When C/T $\bar{2}$ = 0 in modes 0, 1, or 2, Timer 2 is clocked by CLKOUT/4 or CLKOUT/12, depending on the state of T2M (CKCON.5). When C/T $\bar{2}$ = 0 in mode 3, Timer 2 is clocked by CLKOUT/2, regardless of the state of CKCON.5.
T2CON.0	<b>CP/RL<math>\bar{2}</math></b> - Capture/reload flag. When CP/RL $\bar{2}$ =1, Timer 2 captures occur on high-to-low transitions of the T2EX pin, if EXEN2 = 1. When CP/RL $\bar{2}$ = 0, auto-reloads occur when Timer 2 overflows or when high-to-low transitions occur on the T2EX pin, if EXEN2 = 1. If either RCLK or TCLK is set to 1, CP/RL $\bar{2}$ will not function and Timer 2 will operate in auto-reload mode following each overflow.

#### 14.2.4.1 Timer 2 Mode Control

Table 14-6 summarizes how the T2CON bits determine the Timer 2 mode.

Table 14-6. Timer 2 Mode Control Summary

TR2	TCLK	RCLK	CP/RL $\bar{2}$	Mode
0	X	X	X	Timer 2 stopped
1	1	X	X	Baud rate generator
1	X	1	X	Baud rate generator
1	0	0	0	16-bit timer/counter with auto-reload
1	0	0	1	16-bit timer/counter with capture
X = Don't care				

## 14.2.5 Timer 2 — 16-Bit Timer/Counter Mode

Figure 14-4 illustrates how Timer 2 operates in timer/counter mode with the optional capture feature. The  $C/\overline{T}2$  Bit determines whether the 16-bit counter counts CLKOUT cycles (divided by 4 or 12), or high-to-low transitions on the T2 pin. The TR2 Bit enables the counter. When the count increments from 0xFFFF, the TF2 flag is set and the T2OUT pin goes high for one CLKOUT cycle.

### 14.2.5.1 Timer 2 — 16-Bit Timer/Counter Mode with Capture

The Timer 2 capture mode (Figure 14-4) is the same as the 16-bit timer/counter mode, with the addition of the capture registers and control signals.

The  $CP/\overline{RL}2$  Bit in the T2CON SFR enables the capture feature. When  $CP/\overline{RL}2 = 1$ , a high-to-low transition on the T2EX pin when  $EXEN2 = 1$  causes the Timer 2 value to be loaded into the capture registers RCAP2L and RCAP2H.

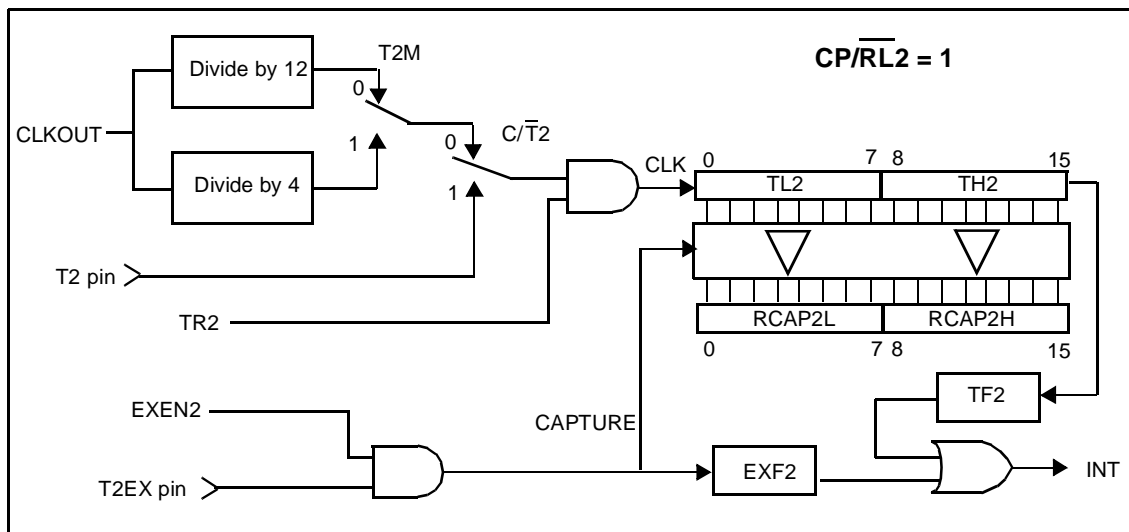

Figure 14-4. Timer 2 - Timer/Counter with Capture

### 14.2.6 Timer 2 — 16-Bit Timer/Counter Mode with Auto-Reload

When  $CP/\overline{RL}2 = 0$ , Timer 2 is configured for the auto-reload mode illustrated in Figure 14-5. Control of counter input is the same as for the other 16-bit counter modes. When the count increments from 0xFFFF, Timer 2 sets the TF2 flag and the starting value is reloaded into TL2 and TH2. Software must preload the starting value into the RCAP2L and RCAP2H registers.

When Timer 2 is in auto-reload mode, a reload can be forced by a high-to-low transition on the T2EX pin, if enabled by  $EXEN2 = 1$ .



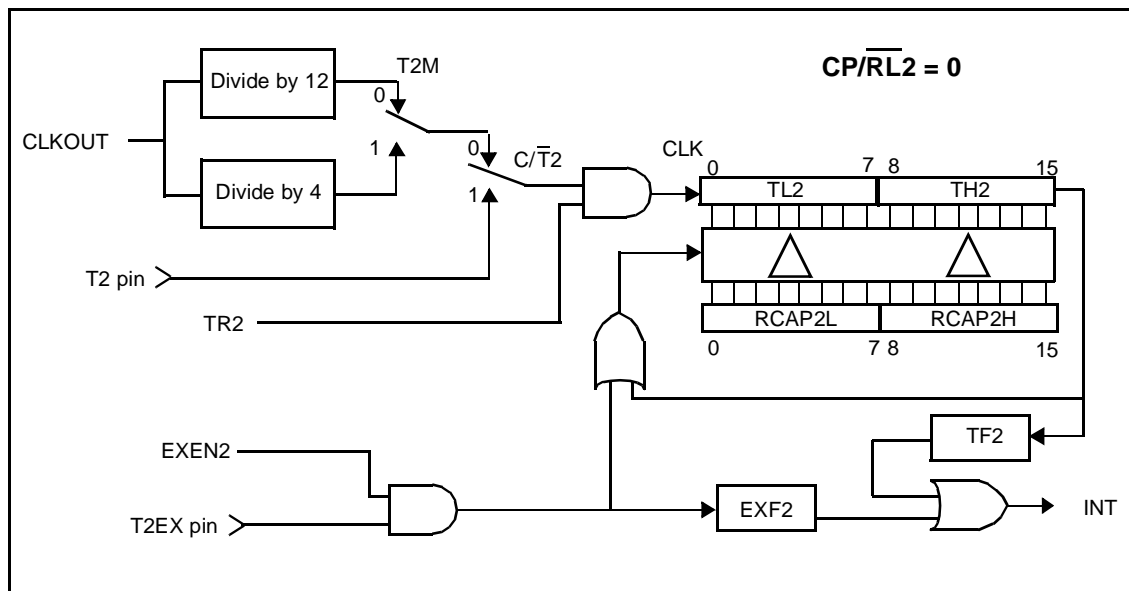

Figure 14-5. Timer 2 - Timer/Counter with Auto Reload

### 14.2.7 Timer 2 — Baud Rate Generator Mode

Setting either RCLK or TCLK to 1 configures Timer 2 to generate baud rates for Serial Port 0 in serial mode 1 or 3. Figure 14-6 is the functional diagram for the Timer 2 baud rate generator mode. In baud rate generator mode, Timer 2 functions in auto-reload mode. However, instead of setting the TF2 flag, the counter overflow is used to generate a shift clock for the serial port function. As in normal auto-reload mode, the overflow also causes the pre-loaded start value in the RCAP2L and RCAP2H Registers to be reloaded into the TL2 and TH2 Registers.

When either  $TCLK = 1$  or  $RCLK = 1$ , Timer 2 is forced into auto-reload operation, regardless of the state of the CP/RL2 Bit. Timer 2 is used as the receive baud clock source when  $RCLK=1$ , and as the transmit baud clock source when  $TCLK=1$ .

When operating as a baud rate generator, Timer 2 does not set the TF2 Bit. In this mode, a Timer 2 interrupt can only be generated by a high-to-low transition on the T2EX pin setting the EXF2 Bit, and only if enabled by  $EXEN2 = 1$ .

The counter time base in baud rate generator mode is  $CLKOUT/2$ . To use an external clock source, set  $C/\overline{T2}$  to 1 and apply the desired clock source to the T2 pin.



*The maximum frequency for an external clock source on the T2 pin is 3 MHz.*

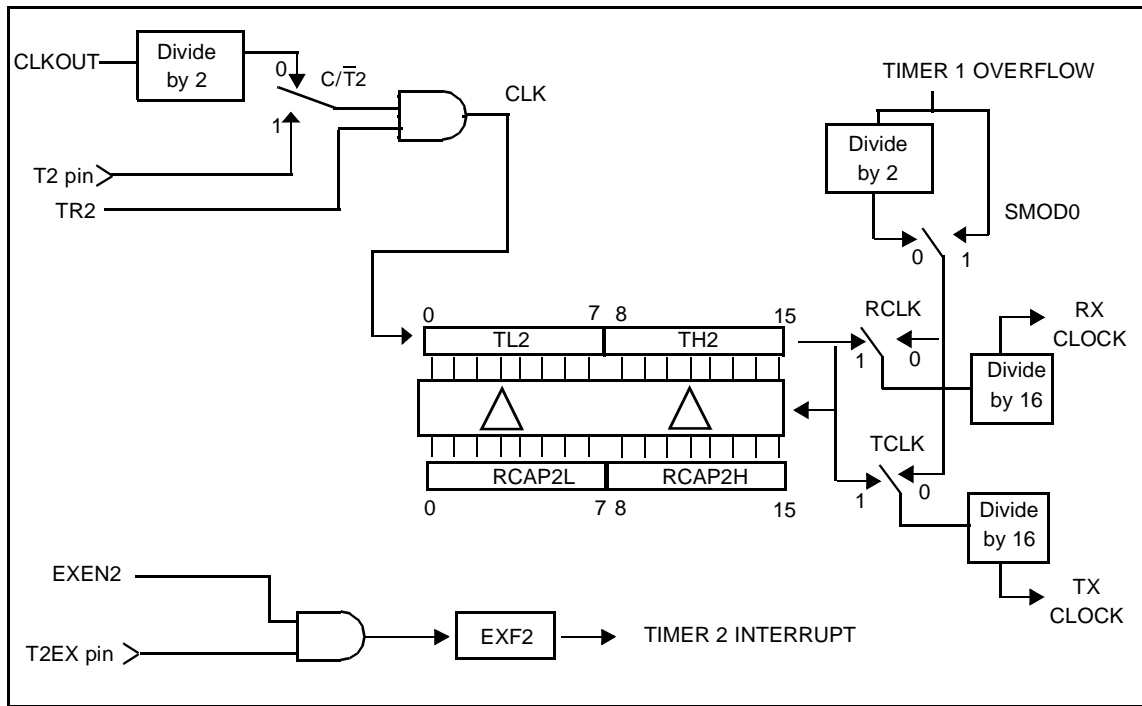

Figure 14-6. Timer 2 - Baud Rate Generator Mode

### 14.3 Serial Interface

The FX2 provides two serial ports. Serial Port 0 operates almost exactly as a standard 8051 serial port; depending on the configured mode (see Tabl e14-7), its baud-clock source can be CLKOUT/4 or CLKOUT/12, Timer 1, Timer 2, or the High-Speed Baud Rate Generator (see Section 14.3.2). Serial Port 1 is identical to Serial Port 0, except that it cannot use Timer 2 as its baud rate generator.

Each serial port can operate in synchronous or asynchronous mode. In synchronous mode, the FX2 generates the serial clock and the serial port operates in half-duplex mode. In asynchronous mode, the serial port operates in full-duplex mode. In all modes, the FX2 double-buffers the incoming data so that a byte of incoming data can be received while firmware is reading the previously-received byte.

Each serial port can operate in one of four modes, as outlined in Tabl e14-7.

Table 14-7. Serial Port Modes

Mode	Sync / Async	Baud-Clock Source	Data Bits	Start / Stop	9th Bit Function
0	Sync	CLKOUT/4 or CLKOUT/12	8	None	None
1	Async	Timer 1 (Ports 0 and 1), Timer 2 (Port 0 only), or High-Speed Baud Rate Generator (Ports 0 and 1)	8	1 start, 1 stop	None
2	Async	CLKOUT/32 or CLKOUT/64	9	1 start, 1 stop	0, 1, or parity
3	Async	Timer 1 (Ports 0 and 1), Timer 2 (Port 0 only), or High-Speed Baud Rate Generator (Ports 0 and 1)	9	1 start, 1 stop	0, 1, or parity
<b>Note:</b> The High-Speed Baud Rate Generator provides 115.2K or 230.4K baud rates (see Section 14.3.2).					

The registers associated with the serial ports are as follows. (Registers PCON and EICON also include some functionality which is not part of the Serial Interface).

- PCON (SFR 0x87) — Bit 7, Serial Port 0 rate control SMOD0 (Table 14-13).
- SCON0 (SFR 0x98) — Serial Port 0 control (Table 14-11).
- SBUF0 (SFR 0x99) — Serial Port 0 transmit/receive buffer.
- EICON (SFR 0xD8) — Bit 7, Serial Port 1 rate control SMOD1 (Table 14-12).
- SCON1 (SFR 0xC0) — Serial Port 1 control (Table 14-14).
- SBUF1 (SFR 0xC1) — Serial Port 1 transmit/receive buffer.
- T2CON (SFR 0xC8) — Baud clock source for modes 1 and 3 (RCLK and TCLK in Table 14-5).
- UART230 (0xE608) — High-Speed Baud Rate Generator enable (see Section 14.3.2, "High-Speed Baud Rate Generator").

### 14.3.1 803x/805x Compatibility

The implementation of the serial interface is similar to that of the Dallas Semiconductor, DS80C320. Table 14-8 summarizes the differences in serial interface implementation between the Intel 8051, the Dallas Semiconductor DS80C320, and the FX2.

Table 14-8. Serial Interface Implementation Comparison

Feature	Intel 8051	Dallas DS80C320	FX2
Number of serial ports	1	2	2
Framing error detection	not implemented	implemented	not implemented
Slave address comparison for multiprocessor communication	not implemented	implemented	not implemented

### 14.3.2 High-Speed Baud Rate Generator

The FX2 incorporates a high-speed baud rate generator which can provide 115.2K and 230.4K baud rates for either or both serial ports, regardless of the FX2's internal clock frequency (12, 24, or 48 MHz).

The high-speed baud rate generator is enabled for Serial Port 0 by setting UART230.0 to 1; it's enabled for Serial Port 1 by setting UART230.1 to 1.

When enabled, the high-speed baud rate generator defaults to 115.2K baud. To select 230.4K baud for Serial Port 0, set SMOD0 (PCON.7) to 1; for Serial Port 1, set SMOD1 (EICON.7) to 1.

Table 14-9. UART230 Register — Address 0xE608

Bit	Function
UART230.7:2	<b>Reserved</b>
UART230.1	<b>230UART1</b> - Enable high-speed baud rate generator for serial port 1. When 230UART1 = 1, a 115.2K baud (if SMOD1 = 0) or 230.4K baud (if SMOD1 = 1) clock is provided to serial port 1. When 230UART1 = 0, serial port 1's baud clock is provided by one of the sources shown in Table 14-7.
UART230.0	<b>230UART0</b> - Enable high-speed baud rate generator for serial port 0. When 230UART0 = 1, a 115.2K baud (if SMOD0 = 0) or 230.4K baud (if SMOD0 = 1) clock is provided to serial port 0. When 230UART1 = 0, serial port 0's baud clock is provided by one of the sources shown in Table 14-7.



When the High-Speed Baud Rate Generator is enabled for either serial port, **neither** port may use Timer 1 as its baud-clock source. Therefore, the allowable combinations of baud-clock sources for Modes 1 and 3 are:

Table 14-10. Allowable Baud-Clock Combinations for Modes 1 and 3

Port 0	Port 1
Timer 1	Timer 1
Timer 2	Timer 1
Timer 2	High-Speed Baud Rate Generator
High-Speed Baud Rate Generator	High-Speed Baud Rate Generator

---

### 14.3.3 Mode 0

Serial mode 0 provides synchronous, half-duplex serial communication. For Serial Port 0, serial data output occurs on the RXD0OUT pin, serial data is received on the RXD0 pin, and the TXD0 pin provides the shift clock for both transmit and receive. For Serial Port 1, the corresponding pins are RXD1OUT, RXD1, and TXD1.

The serial mode 0 baud rate is either  $\text{CLKOUT}/12$  or  $\text{CLKOUT}/4$ , depending on the state of the SM2\_0 bit (or SM2\_1 for Serial Port 1). When SM2\_0 = 0, the baud rate is  $\text{CLKOUT}/12$ , when SM2\_0 = 1, the baud rate is  $\text{CLKOUT}/4$ .

Mode 0 operation is identical to the standard 8051. Data transmission begins when an instruction writes to the SBUF0 (or SBUF1) SFR. The USART shifts the data, LSB first, at the selected baud rate, until the 8-bit value has been shifted out.

Mode 0 data reception begins when the REN\_0 (or REN\_1) bit is set and the RI\_0 (or RI\_1) bit is cleared in the corresponding SCON SFR. The shift clock is activated and the USART shifts data, LSB first, in on each rising edge of the shift clock until 8 bits have been received. One CLKOUT cycle after the 8th bit is shifted in, the RI\_0 (or RI\_1) bit is set and reception stops until the software clears the RI bit.

Figure 14-7 through Figure 14-10 illustrate Serial Port Mode 0 transmit and receive timing for both low-speed ( $\text{CLKOUT}/12$ ) and high-speed ( $\text{CLKOUT}/4$ ) operation. The figures show Port 0 signal names, RXD0, RXD0OUT, and TXD0. The timing is the same for Port 1 signals RXD1, RXD1OUT, and TXD1, respectively.

Table 14-11. SCON0 Register — SFR 98h

Bit	Function															
SCON0.7	<b>SM0_0</b> - Serial Port 0 mode bit 0.															
SCON0.6	<b>SM1_0</b> - Serial Port 0 mode bit 1, decoded as: <table border="1" style="margin-left: auto; margin-right: auto;"> <thead> <tr> <th>SM0_0</th> <th>SM1_0</th> <th>Mode</th> </tr> </thead> <tbody> <tr> <td>0</td> <td>0</td> <td>0</td> </tr> <tr> <td>0</td> <td>1</td> <td>1</td> </tr> <tr> <td>1</td> <td>0</td> <td>2</td> </tr> <tr> <td>1</td> <td>1</td> <td>3</td> </tr> </tbody> </table>	SM0_0	SM1_0	Mode	0	0	0	0	1	1	1	0	2	1	1	3
SM0_0	SM1_0	Mode														
0	0	0														
0	1	1														
1	0	2														
1	1	3														
SCON0.5	<b>SM2_0</b> - Multiprocessor communication enable. In modes 2 and 3, this bit enables the multiprocessor communication feature. If SM2_0 = 1 in mode 2 or 3, then RI_0 will not be activated if the received 9th bit is 0.  If SM2_0=1 in mode 1, then RI_0 will only be activated if a valid stop is received. In mode 0, SM2_0 establishes the baud rate: when SM2_0=0, the baud rate is CLKOUT/12; when SM2_0=1, the baud rate is CLKOUT/4.															
SCON0.4	<b>REN_0</b> - Receive enable. When REN_0=1, reception is enabled.															
SCON0.3	<b>TB8_0</b> - Defines the state of the 9th data bit transmitted in modes 2 and 3.															
SCON0.2	<b>RB8_0</b> - In modes 2 and 3, RB8_0 indicates the state of the 9th bit received. In mode 1, RB8_0 indicates the state of the received stop bit. In mode 0, RB8_0 is not used.															
SCON0.1	<b>TI_0</b> - Transmit interrupt flag. Indicates that the transmit data word has been shifted out. In mode 0, TI_0 is set at the end of the 8th data bit. In all other modes, TI_0 is set when the stop bit is placed on the TXD0 pin. <b>TI_0 must be cleared by firmware.</b>															
SCON0.0	<b>RI_0</b> - Receive interrupt flag. Indicates that serial data word has been received. In mode 0, RI_0 is set at the end of the 8th data bit. In mode 1, RI_0 is set after the last sample of the incoming stop bit, subject to the state of SM2_0. In modes 2 and 3, RI_0 is set at the end of the last sample of RB8_0. <b>RI_0 must be cleared by firmware.</b>															

Table 14-12. EICON (SFR 0xD8) SMOD1 Bit

Bit	Function
EICON.7	<b>SMOD1</b> - Serial Port 1 baud rate doubler enable. When SMOD1 = 1 the baud rate for Serial Port is doubled.

Table 14-13. PCON (SFR 0x87) SMOD0 Bit

Bit	Function
PCON.7	<b>SMOD0</b> - Serial Port 0 baud rate double enable. When SMOD0 = 1, the baud rate for Serial Port 0 is doubled.

Table 14-14. *SCON1 Register — SFR C0h*

Bit	Function															
SCON1.7	<b>SM0_1</b> - Serial Port 1 mode bit 0.															
SCON1.6	<p><b>SM1_1</b> - Serial Port 1 mode bit 1, decoded as:</p> <table border="1"> <thead> <tr> <th><u>SM0_1</u></th> <th><u>SM1_1</u></th> <th><u>Mode</u></th> </tr> </thead> <tbody> <tr> <td>0</td> <td>0</td> <td>0</td> </tr> <tr> <td>0</td> <td>1</td> <td>1</td> </tr> <tr> <td>1</td> <td>0</td> <td>2</td> </tr> <tr> <td>1</td> <td>1</td> <td>3</td> </tr> </tbody> </table>	<u>SM0_1</u>	<u>SM1_1</u>	<u>Mode</u>	0	0	0	0	1	1	1	0	2	1	1	3
<u>SM0_1</u>	<u>SM1_1</u>	<u>Mode</u>														
0	0	0														
0	1	1														
1	0	2														
1	1	3														
SCON1.5	<p><b>SM2_1</b> - Multiprocessor communication enable. In modes 2 and 3, this bit enables the multiprocessor communication feature. If SM2_1 = 1 in mode 2 or 3, then RI_1 will not be activated if the received 9th bit is 0.</p> <p>If SM2_1=1 in mode 1, then RI_1 will only be activated if a valid stop is received. In mode 0, SM2_1 establishes the baud rate: when SM2_1=0, the baud rate is CLKOUT/12; when SM2_1=1, the baud rate is CLKOUT/4.</p>															
SCON1.4	<b>REN_1</b> - Receive enable. When REN_1=1, reception is enabled.															
SCON1.3	<b>TB8_1</b> - Defines the state of the 9th data bit transmitted in modes 2 and 3.															
SCON1.2	<b>RB8_1</b> - In modes 2 and 3, RB8_1 indicates the state of the 9th bit received. In mode 1, RB8_1 indicates the state of the received stop bit. In mode 0, RB8_1 is not used.															
SCON1.1	<b>TI_1</b> - Transmit interrupt flag. Indicates that the transmit data word has been shifted out. In mode 0, TI_1 is set at the end of the 8th data bit. In all other modes, TI_1 is set when the stop bit is placed on the TXD1 pin. <b>TI_1 must be cleared by the software.</b>															
SCON1.0	<b>RI_1</b> - Receive interrupt flag. Indicates that serial data word has been received. In mode 0, RI_1 is set at the end of the 8th data bit. In mode 1, RI_1 is set after the last sample of the incoming stop bit, subject to the state of SM2_1. In modes 2 and 3, RI_1 is set at the end of the last sample of RB8_1. <b>RI_1 must be cleared by the software.</b>															

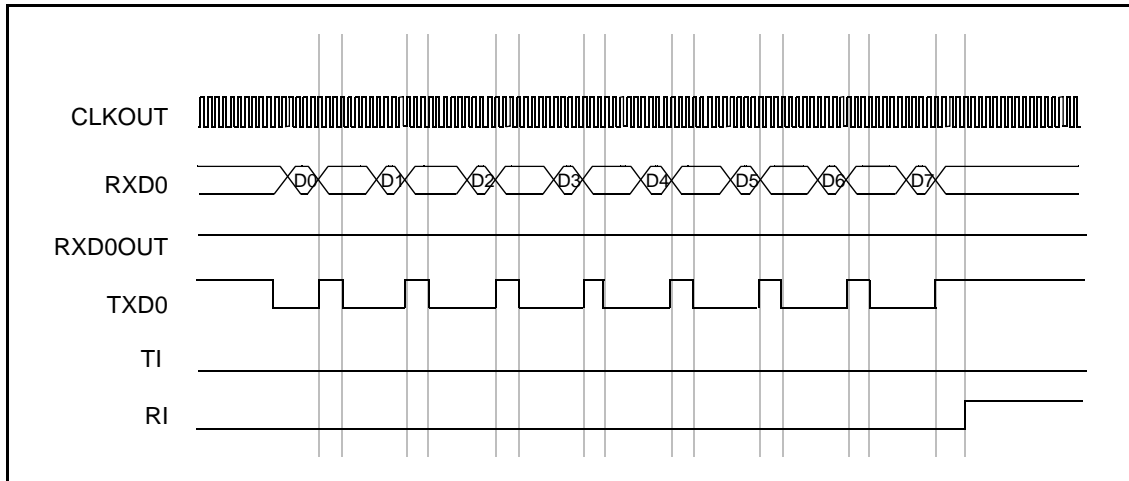

Figure 14-7. Serial Port Mode 0 Receive Timing - Low Speed Operation

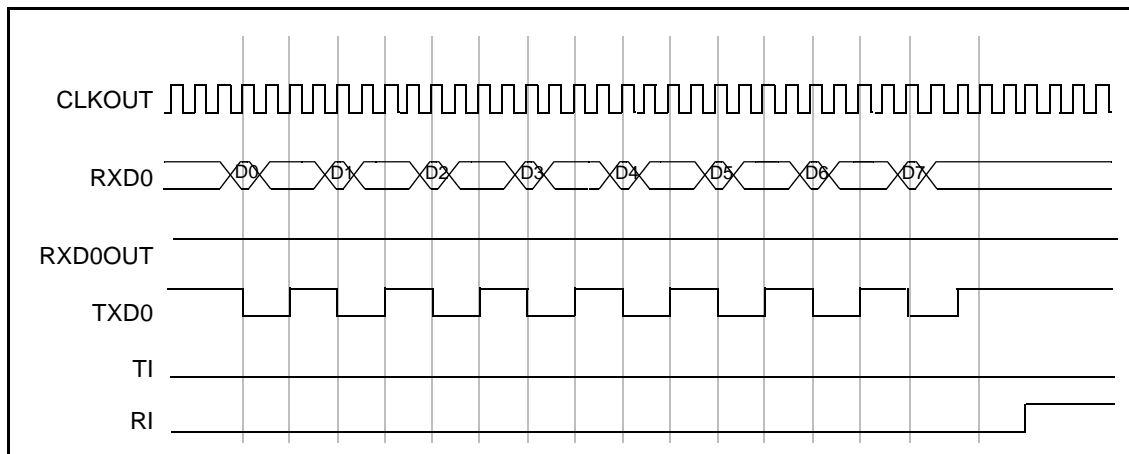

Figure 14-8. Serial Port Mode 0 Receive Timing - High Speed Operation



At both low and high speed in Mode 0, data on RXD0 is sampled two CLKOUT cycles **before** the rising clock edge on TXD0.



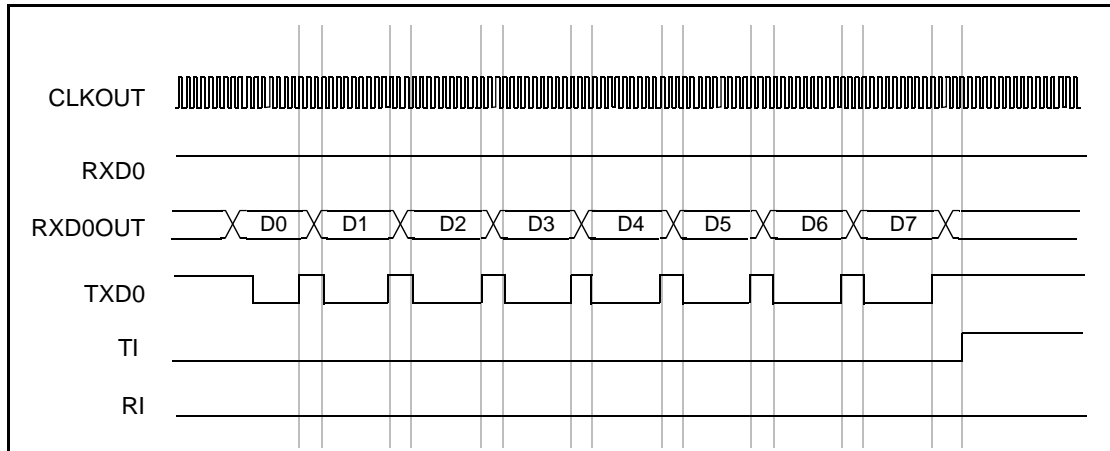

Figure 14-9. Serial Port Mode 0 Transmit Timing - Low Speed Operation

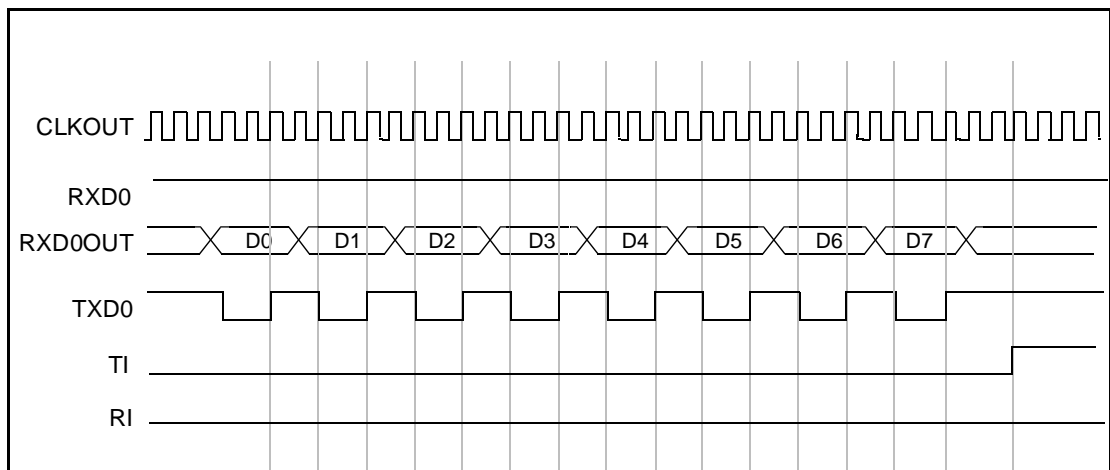

Figure 14-10. Serial Port Mode 0 Transmit Timing - High Speed Operation

### 14.3.4 Mode 1

Mode 1 provides standard asynchronous, full-duplex communication, using a total of 10 bits: 1 start bit, 8 data bits, and 1 stop bit. For receive operations, the stop bit is stored in RB8\_0 (or RB8\_1). Data bits are received and transmitted LSB first.

Mode 1 operation is identical to that of the standard 8051 when Timer 1 uses CLKOUT/12, (T1M=0, the default).

#### 14.3.4.1 Mode 1 Baud Rate

The mode 1 baud rate is a function of timer overflow. Serial Port 0 can use either Timer 1 or Timer 2 to generate baud rates. Serial Port 1 can only use Timer 1. The two serial ports can run at the same baud rate if they both use Timer 1, or different baud rates if Serial Port 0 uses Timer 2 and Serial Port 1 uses Timer 1.

Each time the timer increments from its maximum count (0xFF for Timer 1 or 0xFFFF for Timer 2), a clock is sent to the baud rate circuit. That clock is then divided by 16 to generate the baud rate.

When using Timer 1, the SMOD0 (or SMOD1) Bit selects whether or not to divide the Timer 1 roll-over rate by 2. Therefore, when using Timer 1, the baud rate is determined by the equation:

$$\text{Baud Rate} = \frac{2^{\text{SMODx}}}{32} \times \text{Timer 1 Overflow}$$

When using Timer 2, the baud rate is determined by the equation:

$$\text{Baud Rate} = \frac{\text{Timer 2 Overflow}}{16}$$

To use Timer 1 as the baud rate generator, it is generally best to use Timer 1 mode 2 (8-bit counter with auto-reload), although any counter mode can be used. In mode 2, the Timer 1 reload value is stored in the TH1 register, which makes the complete formula for Timer 1:

$$\text{Baud Rate} = \frac{2^{\text{SMODx}}}{32} \times \frac{\text{CLKOUT}}{(12 - 8 \times \text{T1M}) \times (256 - \text{TH1})}$$

To derive the required TH1 value from a known baud rate when T1M=0, use the equation:

$$\text{TH1} = 256 - \frac{2^{\text{SMODx}} \times \text{CLKOUT}}{384 \times \text{Baud Rate}}$$

To derive the required TH1 value from a known baud rate when T1M=1, use the equation:

$$TH1 = 256 - \frac{2^{SMOD} \times CLKOUT}{128 \times \text{Baud Rate}}$$



Very low serial port baud rates may be achieved with Timer 1 by enabling the Timer 1 interrupt, configuring Timer 1 to mode 1, and using the Timer 1 interrupt to initiate a 16-bit software reload.

Table 14-15 lists sample reload values for a variety of common serial port baud rates, using Timer 1 operating in mode 2 (TMOD.5:4=10) with a CLKOUT/4 clock source (T1M=1) and the full timer rollover (SMOD1=1).

Table 14-15. Timer 1 Reload Values for Common Serial Port Mode 1 Baud Rates

Nominal Rate	CLKOUT = 12 MHz			CLKOUT = 24 MHz			CLKOUT = 48 MHz		
	TH1 Reload Value	Actual Rate	Error	TH1 Reload Value	Actual Rate	Error	TH1 Reload Value	Actual Rate	Error
57600	FD	62500	+8.50%	F9	53571	-6.99%	F3	57692	+0.16%
38400	FB	37500	-2.34%	F6	37500	-2.34%	EC	37500	-2.34%
28800	F9	26786	-6.99%	F3	28846	+0.16%	E6	28846	+0.16%
19200	F6	18750	-2.34%	EC	18750	-2.34%	D9	19230	+0.16%
9600	EC	9375	-2.34%	D9	9615	+0.16%	B2	9615	+0.16%
4800	D9	4807	+0.16%	B2	4807	+0.16%	64	4807	+0.16%
2400	B2	2403	+0.16%	64	2403	+0.16%	—	—	—

Settings: SMOD=1, C/T=0, Timer1 Mode=2, T1M=1  
**Note:** Using rates that are off by 2% or more will not work in all systems.

More accurate baud rates may be achieved by using Timer 2 as the baud rate generator. To use Timer 2 as the baud rate generator, configure Timer 2 in auto-reload mode and set the TCLK and/or RCLK bits in the T2CON SFR. TCLK selects Timer 2 as the baud rate generator for the transmitter; RCLK selects Timer 2 as the baud rate generator for the receiver. The 16-bit reload value for Timer 2 is stored in the RCAP2L and RCA2H SFRs, which makes the equation for the Timer 2 baud rate:

$$\text{Baud Rate} = \frac{CLKOUT}{32 \times (65536 - 256 \times RCAP2H + RCAP2L)}$$

To derive the required RCAP2H and RCAP2L values from a known baud rate, use the equation:

$$\text{RCAP2H:L} = 65536 - \frac{\text{CLKOUT}}{32 \times \text{Baud Rate}}$$

When either RCLK or TCLK is set, the TF2 flag is not set on a Timer 2 rollover and the T2EX reload trigger is disabled.

Table 14-16 lists sample RCAP2H:L reload values for a variety of common serial baud rates.

Table 14-16. Timer 2 Reload Values for Common Serial Port Mode 1 Baud Rates

Nominal Rate	CLKOUT = 12 MHz			CLKOUT = 24 MHz			CLKOUT = 48 MHz		
	RCAP2H:L Reload Value	Actual Rate	Error	RCAP2H:L Reload Value	Actual Rate	Error	RCAP2H:L Reload Value	Actual Rate	Error
57600	FFF9	53571	-6.99%	FFF3	57692	+0.16%	FFE6	57692	+0.16%
38400	FFF6	37500	-2.34%	FFEC	37500	-2.34%	FFD9	38461	+0.16%
28800	FFF3	28846	+0.16%	FFE6	28846	+0.16%	FFCC	28846	+0.16%
19200	FFEC	18750	-2.34%	FFD9	19230	+0.16%	FFB2	19230	+0.16%
9600	FFD9	9615	+0.16%	FFB2	9615	+0.16%	FF64	9615	+0.16%
4800	FFB2	4807	+0.16%	FF64	4807	+0.16%	FEC8	4807	+0.16%
2400	FF64	2403	+0.16%	FEC8	2403	+0.16%	FD90	2403	+0.16%

**Note:** using rates that are off by 2.3% or more will not work in all systems.

#### 14.3.4.2 Mode 1 Transmit

Figure 14-11 illustrates the mode 1 transmit timing. In mode 1, the USART begins transmitting after the first rollover of the divide-by-16 counter after the software writes to the SBUF0 (or SBUF1) register. The USART transmits data on the TXD0 (or TXD1) pin in the following order: start bit, 8 data bits (LSB first), stop bit. The TI\_0 (or TI\_1) bit is set 2 CLKOUT cycles after the stop bit is transmitted.

#### 14.3.5 Mode 1 Receive

Figure 14-12 illustrates the mode 1 receive timing. Reception begins at the falling edge of a start bit received on the RXD0 (or RXD1) pin, when enabled by the REN\_0 (or REN\_1) Bit. For this purpose, the RXD0 (or RXD1) pin is sampled 16 times per bit for any baud rate. When a falling edge

of a start bit is detected, the divide-by-16 counter used to generate the receive clock is reset to align the counter rollover to the bit boundaries.

For noise rejection, the serial port establishes the content of each received bit by a majority decision of 3 consecutive samples in the middle of each bit time. For the start bit, if the falling edge on the RXD0 (or RXD1) pin is not verified by a majority decision of 3 consecutive samples (low), then the serial port stops reception and waits for another falling edge on the RXD0 (or RXD1) pin.

At the middle of the stop bit time, the serial port checks for the following conditions:

- $RI\_0$  (or  $RI\_1$ ) = 0
- If  $SM2\_0$  (or  $SM2\_1$ ) = 1, the state of the stop bit is 1  
(If  $SM2\_0$  (or  $SM2\_1$ ) = 0, the state of the stop bit doesn't matter.)

If the above conditions are met, the serial port then writes the received byte to the SBUF0 (or SBUF1) Register, loads the stop bit into RB8\_0 (or RB8\_1), and sets the RI\_0 (or RI\_1) Bit. If the above conditions are not met, the received data is lost, the SBUF Register and RB8 Bit are not loaded, and the RI Bit is not set.

After the middle of the stop bit time, the serial port waits for another high-to-low transition on the (RXD0 or RXD1) pin.

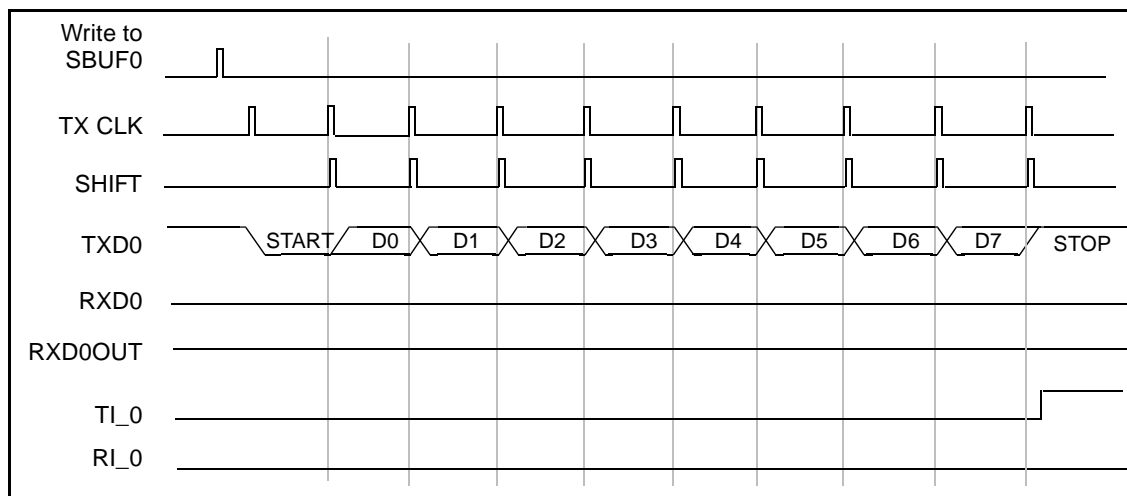

Figure 14-11. Serial Port 0 Mode 1 Transmit Timing

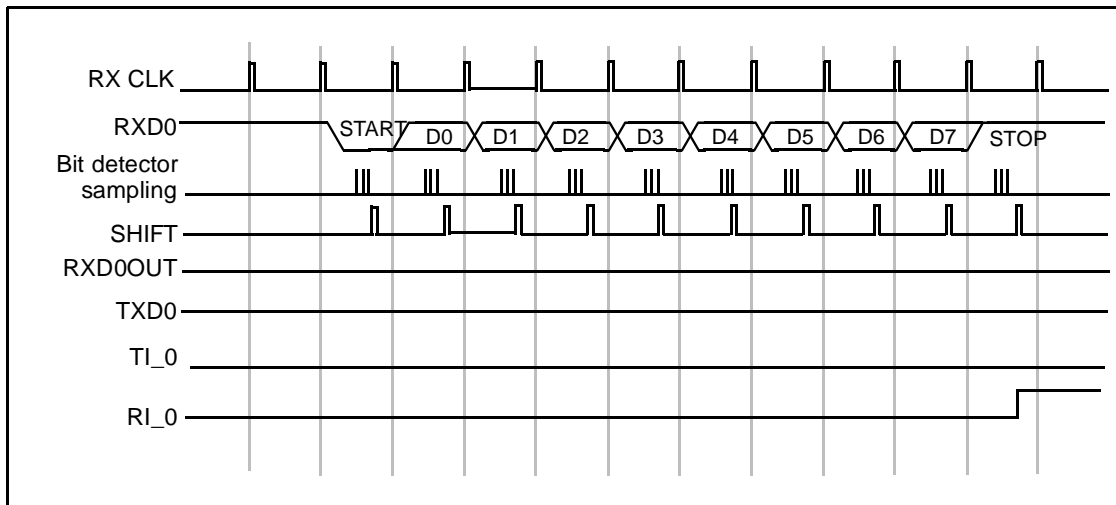

Figure 14-12. Serial Port 0 Mode 1 Receive Timing

### 14.3.6 Mode 2

Mode 2 provides asynchronous, full-duplex communication, using a total of 11 bits: 1 start bit, 8 data bits, a programmable 9th bit, and 1 stop bit. The data bits are transmitted and received LSB first. For transmission, the 9th bit is determined by the value in TB8\_0 (or TB8\_1). To use the 9th bit as a parity bit, move the value of the P bit (SFR PSW.0) to TB8\_0 (or TB8\_1).

The Mode 2 baud rate is either CLKOUT/32 or CLKOUT/64, as determined by the SMOD0 (or SMOD1) bit. The formula for the mode 2 baud rate is:

$$\text{Baud Rate} = \frac{2^{\text{SMODx}} \times \text{CLKOUT}}{64}$$

Mode 2 operation is identical to the standard 8051.

#### 14.3.6.1 Mode 2 Transmit

Figure 14-13 illustrates the mode 2 transmit timing. Transmission begins after the first rollover of the divide-by-16 counter following a software write to SBUF0 (or SBUF1). The USART shifts data out on the TXD0 (or TXD1) pin in the following order: start bit, data bits (LSB first), 9th bit, stop bit. The TI\_0 (or TI\_1) Bit is set when the stop bit is placed on the TXD0 (or TXD1) pin.

### 14.3.6.2 Mode 2 Receive

Figure 14-14 illustrates the mode 2 receive timing. Reception begins at the falling edge of a start bit received on the RXD0 (or RXD1) pin, when enabled by the REN\_0 (or REN\_1) Bit. For this purpose, the RXD0 (or RXD1) pin is sampled 16 times per bit for any baud rate. When a falling edge of a start bit is detected, the divide-by-16 counter used to generate the receive clock is reset to align the counter rollover to the bit boundaries.

For noise rejection, the serial port establishes the content of each received bit by a majority decision of 3 consecutive samples in the middle of each bit time. For the start bit, if the falling edge on the RXD0 (or RXD1) pin is not verified by a majority decision of 3 consecutive samples (low), then the serial port stops reception and waits for another falling edge on the RXD0 (or RXD1) pin.

At the middle of the stop bit time, the serial port checks for the following conditions:

- RI\_0 (or RI\_1) = 0
- If SM2\_0 (or SM2\_1) = 1, the state of the stop bit is 1.  
(If SM2\_0 (or SM2\_1) = 0, the state of the stop bit doesn't matter.)

If the above conditions are met, the serial port then writes the received byte to the SBUF0 (or SBUF1) Register, loads the stop bit into RB8\_0 (or RB8\_1), and sets the RI\_0 (or RI\_1) Bit. If the above conditions are not met, the received data is lost, the SBUF Register and RB8 Bit are not loaded, and the RI Bit is not set. After the middle of the stop bit time, the serial port waits for another high-to-low transition on the RXD0 (or RXD1) pin.

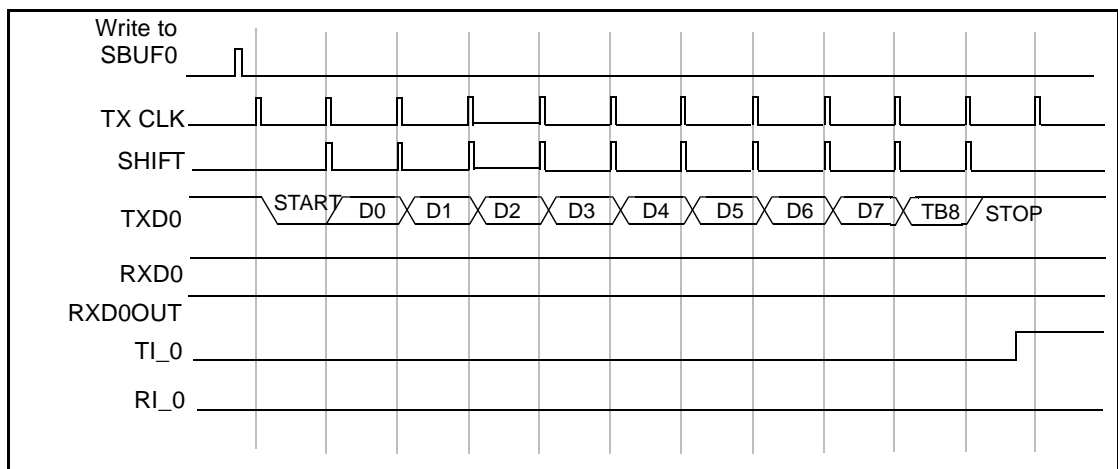

Figure 14-13. Serial Port 0 Mode 2 Transmit Timing

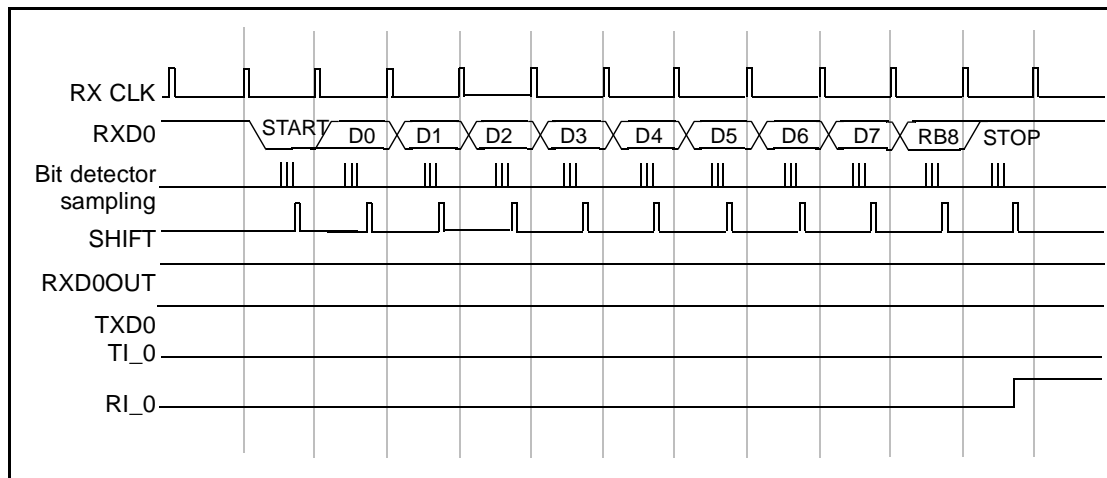

Figure 14-14. Serial Port 0 Mode 2 Receive Timing

### 14.3.7 Mode 3

Mode 3 provides asynchronous, full-duplex communication, using a total of 11 bits: 1 start bit, 8 data bits, a programmable 9th bit, and 1 stop bit. The data bits are transmitted and received LSB first.

The mode 3 transmit and operations are identical to mode 2. The mode 3 baud rate generation is identical to mode 1. That is, mode 3 is a combination of mode 2 protocol and mode 1 baud rate. Figure 14-15 illustrates the mode 3 transmit timing. Figure 14-16 illustrates the mode 3 receive timing.

Mode 3 operation is identical to that of the standard 8051 when Timer 1 uses CLKOUT/12, (T1M=0, the default).



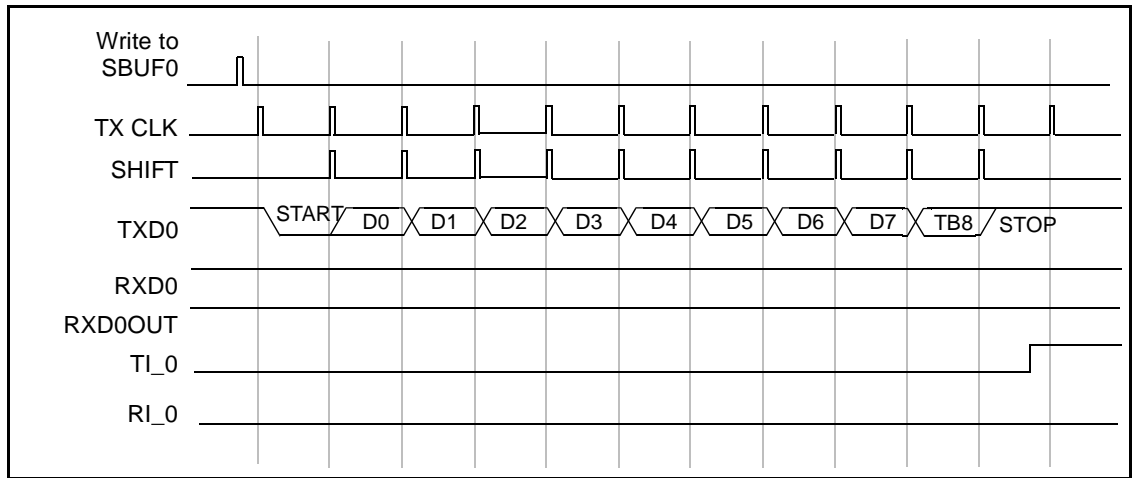

Figure 14-15. Serial Port 0 Mode 3 Transmit Timing

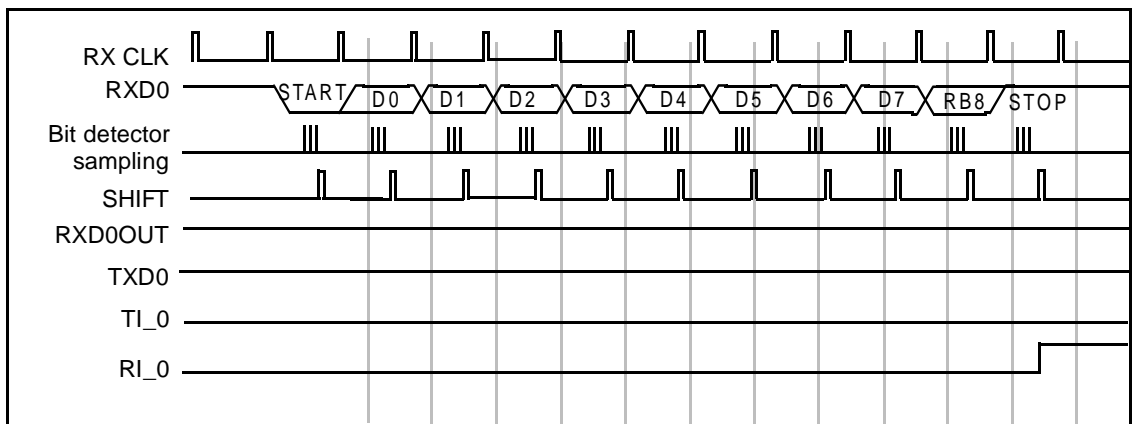

Figure 14-16. Serial Port 0 Mode 3 Receive Timing



## Chapter 15 Registers

---

### 15.1 Introduction

---

This section describes the EZ-USB FX2 registers in the order they appear in the EZ-USB FX2 memory map, see Figure 5-4. The registers are named according to the following conventions.

*Most registers deal with endpoints.* The general register format is **DDDnFFF**, where:

**DDD** is endpoint direction, IN or OUT with respect to the USB host.

**n** is the endpoint number, where:

- “ISO” indicates isochronous endpoints as a group.

**FFF** is the function, where:

- CS is a control and status register
- IRQ is an Interrupt Request bit
- IE is an Interrupt Enable bit
- BC, BCL, and BCH are byte count registers. BC is used for single byte counts, and BCH/BCL are used as the high and low bytes of 16-bit byte counts.
- DATA is a single-register access to a FIFO.
- BUF is the start address of a buffer.

---

#### 15.1.1 Example Register Formats

- EP1INBC is the Endpoint 1 IN byte count.

### 15.1.2 Other Conventions

**USB** Indicates a global (not endpoint-specific) USB function.

**ADDR** Is an address.

**VAL** Means valid.

**FRAME** Is a frame count.

**PTR** Is an address pointer.

Register Name		Register Function				Address	
b7	b6	b5	b4	b3	b2	b1	b0
<b>bitname</b>	<b>bitname</b>	<b>bitname</b>	<b>bitname</b>	<b>bitname</b>	<b>bitname</b>	<b>bitname</b>	<b>bitname</b>
R, W access	R, W access	R, W access	R, W access	R, W access	R, W access	R, W access	R, W access
Default val	Default val	Default val	Default val	Default val	Default val	Default val	Default val

Figure 15-1. Register Description Format

Figure 15-1 illustrates the register description format used in this chapter.

- The top line shows the register name, functional description, and address in the EZ-USB FX2 memory.
- The second line shows the bit position in the register.
- The third line shows the name of each bit in the register.
- The fourth line shows CPU accessibility: R(ead), W(rite), or R/W.
- The fifth line shows the default value. These values apply after a Power-On-Reset (POR).

## 15.2 Special Function Registers (SFR)

FX2 implements many control registers as SFRs (Special Function Registers). These SFRs are shown in Table 15-1. Bold type indicates sfrs which are not in the standard 8051, but are included in the FX2.

Table 15-1. FX2 Special Function Registers (SFR)

x	8x	9x	Ax	Bx	Cx	Dx	Ex	Fx
0	<b>IOA</b>	<b>IOB</b>	<b>IOC</b>	<b>IOD</b>	<b>SCON1</b>	PSW	ACC	B
1	SP	<b>EXIF</b>	<b>INT2CLR</b>	<b>IOE</b>	<b>SBUF1</b>			
2	DPL0	<b>MPAGE</b>	<b>INT4CLR</b>	<b>OEA</b>				
3	DPH0			<b>OEB</b>				
4	<b>DPL1</b>			<b>OEC</b>				
5	<b>DPH1</b>			<b>OED</b>				
6	<b>DPS</b>			<b>OEE</b>				
7	PCON							
8	TCON	SCON0	<b>IE</b>	<b>IP</b>	<b>T2CON</b>	<b>EICON</b>	<b>EIE</b>	<b>EIP</b>
9	TMOD	SBUF0						
A	TL0	<b>AUTOPTRH1</b>	<b>EP2468STAT</b>	<b>EP01STAT</b>	<b>RCAP2L</b>			
B	TL1	<b>AUTOPTRL1</b>	<b>EP24FIFOFLGS</b>	<b>GPIFTRIG</b>	<b>RCAP2H</b>			
C	TH0	<b>AUTODAT1</b>	<b>EP68FIFOFLGS</b>		<b>TL2</b>			
D	TH1	<b>AUTOPTRH2</b>		<b>GPIFSGL-DATH</b>	<b>TH2</b>			
E	<b>CKCON</b>	<b>AUTOPTRL2</b>		<b>GPIFSGL-DATLX</b>				
F		<b>AUTODAT2</b>	<b>AUTOPTR-SETUP</b>	<b>GPIFSGL-DATLNOX</b>				

## 15.3 About SFRS

Because the SFRs are directly-addressable internal registers, firmware can access them quickly, without the overhead of loading the data pointer and performing a MOVX instruction. For example, the firmware reads the FX2 Port B pins using a single instruction, as shown in Figure 15-2.

```
mov    a, IOB
```

Figure 15-2. Single Instruction to Read Port B

Similarly, firmware writes the value 0x55 to Port C using only one MOV instruction, as shown in Figure 15-3.

```
mov    IOC, #55h
```

Figure 15-3. Single Instruction to Write to Port C

SFRs in Table 15-1 rows 0 and 8 are bit-addressable; individual bits of the registers may be efficiently set, cleared, or toggled using special bit-addressing instructions (e.g., **setb IOB.2** sets bit 2 of the IOB register).

IOA		Port A (bit addressable)						SFR 0x80
b7	b6	b5	b4	b3	b2	b1	b0	
<b>D7</b>	<b>D6</b>	<b>D5</b>	<b>D4</b>	<b>D3</b>	<b>D2</b>	<b>D1</b>	<b>D0</b>	
R/W	R/W	R/W	R/W	R/W	R/W	R/W	R/W	
X	X	X	X	X	X	X	X	

**IOB** **Port B (bit addressable)** **SFR 0x90**

b7	b6	b5	b4	b3	b2	b1	b0
<b>D7</b>	<b>D6</b>	<b>D5</b>	<b>D4</b>	<b>D3</b>	<b>D2</b>	<b>D1</b>	<b>D0</b>
R/W	R/W	R/W	R/W	R/W	R/W	R/W	R/W
x	x	x	x	x	x	x	x

**AUTOPTRH1** **Autopointer 1 Address HIGH** **SFR 0x9A**

b7	b6	b5	b4	b3	b2	b1	b0
<b>A15</b>	<b>A14</b>	<b>A13</b>	<b>A12</b>	<b>A11</b>	<b>A10</b>	<b>A9</b>	<b>A8</b>
R/W	R/W	R/W	R/W	R/W	R/W	R/W	R/W
0	0	0	0	0	0	0	0

**AUTOPTRL1** **Autopointer 1 Address LOW** **SFR 0x9B**

b7	b6	b5	b4	b3	b2	b1	b0
<b>A7</b>	<b>A6</b>	<b>A5</b>	<b>A4</b>	<b>A3</b>	<b>A2</b>	<b>A1</b>	<b>A0</b>
R/W	R/W	R/W	R/W	R/W	R/W	R/W	R/W
0	0	0	0	0	0	0	0

**AUTODAT1** **Autodata 1** **SFR 0x9C\***

b7	b6	b5	b4	b3	b2	b1	b0
<b>D7</b>	<b>D6</b>	<b>D5</b>	<b>D4</b>	<b>D3</b>	<b>D2</b>	<b>D1</b>	<b>D0</b>
R/W	R/W	R/W	R/W	R/W	R/W	R/W	R/W
x	x	x	x	x	x	x	x

\*Also appears in the FX2 register file as XAUTODATA1 at 0xE67B.

**AUTOPTRH2** **Autopointer 2 Address HIGH** **SFR 0x9D**

b7	b6	b5	b4	b3	b2	b1	b0
<b>A15</b>	<b>A14</b>	<b>A13</b>	<b>A12</b>	<b>A11</b>	<b>A10</b>	<b>A9</b>	<b>A8</b>
R/W	R/W	R/W	R/W	R/W	R/W	R/W	R/W
0	0	0	0	0	0	0	0

**AUTOPTL2**                      **Autopointer 2 Address LOW**                      **SFR 0x9E**

b7	b6	b5	b4	b3	b2	b1	b0
<b>A7</b>	<b>A6</b>	<b>A5</b>	<b>A4</b>	<b>A3</b>	<b>A2</b>	<b>A1</b>	<b>A0</b>
R/W	R/W	R/W	R/W	R/W	R/W	R/W	R/W
0	0	0	0	0	0	0	0

**AUTODAT2**                      **Autodata 2**                      **SFR 0x9F\***

b7	b6	b5	b4	b3	b2	b1	b0
<b>D7</b>	<b>D6</b>	<b>D5</b>	<b>D4</b>	<b>D3</b>	<b>D2</b>	<b>D1</b>	<b>D0</b>
R/W	R/W	R/W	R/W	R/W	R/W	R/W	R/W
x	x	x	x	x	x	x	x

\*Also appears in the FX2 register file as XAUTODATA2 at 0xE67C.

**IOC**                      **Port C (bit addressable)**                      **SFR 0xA0**

b7	b6	b5	b4	b3	b2	b1	b0
<b>D7</b>	<b>D6</b>	<b>D5</b>	<b>D4</b>	<b>D3</b>	<b>D2</b>	<b>D1</b>	<b>D0</b>
R/W	R/W	R/W	R/W	R/W	R/W	R/W	R/W
x	x	x	x	x	x	x	x

**INT2CLR**                      **Interrupt 2 Clear**                      **SFR 0xA1**

b7	b6	b5	b4	b3	b2	b1	b0
<b>x</b>	<b>x</b>	<b>x</b>	<b>x</b>	<b>x</b>	<b>x</b>	<b>x</b>	<b>x</b>
W	W	W	W	W	W	W	W
x	x	x	x	x	x	x	x

**INT4CLR**                      **Interrupt 4 Clear**                      **SFR 0xA2**

b7	b6	b5	b4	b3	b2	b1	b0
<b>x</b>	<b>x</b>	<b>x</b>	<b>x</b>	<b>x</b>	<b>x</b>	<b>x</b>	<b>x</b>
W	W	W	W	W	W	W	W
x	x	x	x	x	x	x	x



Writing any value to INT2CLR or INT4CLR clears the INT2 or INT4 interrupt request bit for the INT2/INT4 interrupt currently being serviced.



Writing to one of these registers has the same effect as clearing the appropriate interrupt request bit in the FX2 external register space. For example, suppose the EP2 Empty Flag interrupt is asserted. The FX2 automatically sets bit 1 of the EP2FIFOIRQ register (in External Data memory space, at 0xE651), and asserts the INT4 interrupt request.

Using autovectoring, the FX2 automatically calls (vectors to) the EP2\_FIFO\_EMPTY 2 Interrupt Service Routine (ISR). The first task in the ISR is to clear the interrupt request bit, EP2FIFOIRQ.1. The firmware can do this either by accessing the EP2FIFOIRQ register (at 0xE651) and writing a 1 to bit 1, or simply by writing any value to INT4CLR. The first method requires the use of the data pointer, which must be saved and restored along with the accumulator in an ISR. The second method is much faster and does not require saving the data pointer, so it is preferred.

EP2468STAT		Endpoint(s) 2,4,6,8 Status Flags				SFR 0xAA	
b7	b6	b5	b4	b3	b2	b1	b0
EP8F	EP8E	EP6F	EP6E	EP4F	EP4E	EP2F	EP2E
R	R	R	R	R	R	R	R
0	1	0	1	1	0	1	0

The bits in EP2468STAT correspond to Endpoint Status bits in the FX2 register file, as follows:

Table 15-2. SFR and FX2 Register File Correspondences

Bit	EPSTAT SFR	FX2 Register.Bit	FX2 Register File address
7	EP8 Full flag	EP8CS.3	E6A6
6	EP8 Empty flag	EP8CS.2	E6A6
5	EP6 Full flag	EP6CS.3	E6A5
4	EP6 Empty flag	EP6CS.2	E6A5
3	EP4 Full flag	EP4CS.3	E6A4
2	EP4 Empty flag	EP4CS.2	E6A4
1	EP2 Full flag	EP2CS.3	E6A3
0	EP2 Empty flag	EP2CS.2	E6A3

<b>EP24FIFOFLGS</b>	<b>Endpoint(s) 2, 4 Slave FIFO Status Flags</b>	<b>SFR 0xAB</b>
---------------------	---	-----------------

b7	b6	b5	b4	b3	b2	b1	b0
0	EP4PF	EP4EF	EP4FF	0	EP2PF	EP2EF	EP2FF
R	R	R	R	R	R	R	R
0	0	1	0	0	0	1	0

<b>EP68FIFOFLGS</b>	<b>Endpoint(s) 6, 8 Slave FIFO Status Flags</b>	<b>SFR 0xAC</b>
---------------------	---	-----------------

b7	b6	b5	b4	b3	b2	b1	b0
0	EP8PF	EP8EF	EP8FF	0	EP6PF	EP6EF	EP6FF
R	R	R	R	R	R	R	R
0	1	1	0	0	1	1	0

<b>AUTOPTTRSETUP</b>	<b>Autopointer(s) 1 &amp; 2 Setup</b>	<b>SFR 0xAF</b>
----------------------	---------------------------------------	-----------------

b7	b6	b5	b4	b3	b2	b1	b0
0	0	0	0	0	APTR2INC	APTR1INC	EXTACC
R/W	R/W	R/W	R/W	R/W	R/W	R/W	R/W
0	0	0	0	0	1	1	0

FX2 provides two identical autopointers. They are similar to the internal “DPTR” data pointers, but with an additional feature: each can automatically increment after every memory access. Using one or both of the autopointers, FX2 firmware can perform very fast block memory transfers.

The AUTOPTTRSETUP register is configured as follows:

- Set the APTRnINC=0 to freeze the address pointer, APTRnINC=1 to automatically increment it for every read or write of an AUTODATn or XAUTODATn register. This bit defaults to 1, enabling the auto-increment feature.
- To access on-chip memory: When accessing internal memory, the AUTODATn SFRs are used, providing the fastest use of the autopointer.
- To access off-chip memory using the autopointer, set EXTACC=1. When this bit is set, there are two restrictions:

1. The XAUTODATn registers in the FX2 register file (at 0xE67B and 0xE67C) must be used for autopointer accesses to off-chip memory. The SFR versions of these registers cannot be used to access off-chip data memory. The SFR AUTODATn registers can, however, still be used to access on-chip FX2 memory when EXTACC=1.
2. Since the XAUTODATn registers are in the FX2 register file at external data memory locations 0xE67B and 0xE67C, these two memory locations cannot be used for code or data.

The firmware then writes a 16-bit address to AUTOPTRHn/Ln. Then, for every read or write of an AUTODATn or XAUTODATn register, the address pointer automatically increments (if APTRnINC=1).

**IOD** **Port D (bit addressable)** **SFR 0xB0**

b7	b6	b5	b4	b3	b2	b1	b0
<b>D7</b>	<b>D6</b>	<b>D5</b>	<b>D4</b>	<b>D3</b>	<b>D2</b>	<b>D1</b>	<b>D0</b>
R/W	R/W	R/W	R/W	R/W	R/W	R/W	R/W
x	x	x	x	x	x	x	x

FX2 I/O ports PORTA-PORTD appear as bit-addressable SFRs. Reading a register or bit returns the logic level of the port pin that's two CLKOUT-clocks old. Writing a register bit writes the port latch. Whether or not the port latch value appears on the I/O pin depends on the state of the pin's OE (Output Enable) bit. The I/O pins may also be assigned alternate function values, in which case the IOx and OEx bit values are overridden on a bit-by-bit basis.

IOD is bit-addressable; see Figure 15-4.

```

setb  IOD.2           ; set bit 2 of IOD SFR

```

*Figure 15-4. Use Bit 2 to set PORTD - Single Instruction*

**IOE** **Port E** **SFR 0xB1**

b7	b6	b5	b4	b3	b2	b1	b0
<b>D7</b>	<b>D6</b>	<b>D5</b>	<b>D4</b>	<b>D3</b>	<b>D2</b>	<b>D1</b>	<b>D0</b>
R/W	R/W	R/W	R/W	R/W	R/W	R/W	R/W
x	x	x	x	x	x	x	x

IO port PORTE is also accessed using an SFR, but unlike the PORTA-PORTD SFRs, it is not bit-addressable; see Figure 15-5.

```

mov    a,IOE
or     a,#00001000b    ; set bit 3
mov    IOE,a
    
```

Figure 15-5. Use OR to Set Bit 3

**OEA** **Port A Output Enable** **SFR 0xB2**

b7	b6	b5	b4	b3	b2	b1	b0
<b>D7</b>	<b>D6</b>	<b>D5</b>	<b>D4</b>	<b>D3</b>	<b>D2</b>	<b>D1</b>	<b>D0</b>
R/W	R/W	R/W	R/W	R/W	R/W	R/W	R/W
0	0	0	0	0	0	0	0

**OEB** **Port B Output Enable** **SFR 0xB3**

b7	b6	b5	b4	b3	b2	b1	b0
<b>D7</b>	<b>D6</b>	<b>D5</b>	<b>D4</b>	<b>D3</b>	<b>D2</b>	<b>D1</b>	<b>D0</b>
R/W	R/W	R/W	R/W	R/W	R/W	R/W	R/W
0	0	0	0	0	0	0	0

**OEC** **Port C Output Enable** **SFR 0xB4**

b7	b6	b5	b4	b3	b2	b1	b0
<b>D7</b>	<b>D6</b>	<b>D5</b>	<b>D4</b>	<b>D3</b>	<b>D2</b>	<b>D1</b>	<b>D0</b>
R/W	R/W	R/W	R/W	R/W	R/W	R/W	R/W
0	0	0	0	0	0	0	0

**OED** **Port D Output Enable** **SFR 0xB5**

b7	b6	b5	b4	b3	b2	b1	b0
<b>D7</b>	<b>D6</b>	<b>D5</b>	<b>D4</b>	<b>D3</b>	<b>D2</b>	<b>D1</b>	<b>D0</b>
R/W	R/W	R/W	R/W	R/W	R/W	R/W	R/W
0	0	0	0	0	0	0	0

**OEE** **Port E Output Enable** **SFR 0xB6**

b7	b6	b5	b4	b3	b2	b1	b0
<b>D7</b>	<b>D6</b>	<b>D5</b>	<b>D4</b>	<b>D3</b>	<b>D2</b>	<b>D1</b>	<b>D0</b>
R/W	R/W	R/W	R/W	R/W	R/W	R/W	R/W
0	0	0	0	0	0	0	0

The bits in 0EA - 0EE turn on the output buffers for the five IO Ports PORTA-PORTE. Setting a bit to 1 turns on the output buffer, setting it to 0 turns the buffer off.

**EP01STAT** **Endpoint 0 and 1 Status** **SFR 0xBA**

b7	b6	b5	b4	b3	b2	b1	b0
<b>0</b>	<b>0</b>	<b>0</b>	<b>0</b>	<b>0</b>	<b>EP1INBSY</b>	<b>EP1OUTBSY</b>	<b>EP0BSY</b>
R	R	R	R	R	R	R	R
0	0	0	0	0	0	0	0

**GPIFTRIG** **Endpoint 2,4,6,8 GPIF Slave** **SFR 0xBB**  
*see Section 15.14* **FIFO Trigger**

b7	b6	b5	b4	b3	b2	b1	b0
<b>DONE</b>	<b>0</b>	<b>0</b>	<b>0</b>	<b>0</b>	<b>R/W</b>	<b>EP1</b>	<b>EP0</b>
R/W	R	R	R	R	R/W	R/W	R/W
1	0	0	0	0	x	x	x

**GPIFSGLDATH      GPIF Data HIGH (16-bit mode only)      SFR 0xBD**

b7	b6	b5	b4	b3	b2	b1	b0
<b>D15</b>	<b>D14</b>	<b>D13</b>	<b>D12</b>	<b>D11</b>	<b>D10</b>	<b>D9</b>	<b>D8</b>
R/W	R/W	R/W	R/W	R/W	R/W	R/W	R/W
x	x	x	x	x	x	x	x

**GPIFSGLDATLX      GPIF Data LOW w/Trigger      SFR 0xBE**

b7	b6	b5	b4	b3	b2	b1	b0
<b>D7</b>	<b>D6</b>	<b>D5</b>	<b>D4</b>	<b>D3</b>	<b>D2</b>	<b>D1</b>	<b>D0</b>
R/W	R/W	R/W	R/W	R/W	R/W	R/W	R/W
x	x	x	x	x	x	x	x

**GPIFSGLDATLNOX      GPIF Data LOW w/No Trigger      SFR 0xBF**

b7	b6	b5	b4	b3	b2	b1	b0
<b>D7</b>	<b>D6</b>	<b>D5</b>	<b>D4</b>	<b>D3</b>	<b>D2</b>	<b>D1</b>	<b>D0</b>
R	R	R	R	R	R	R	R
x	x	x	x	x	x	x	x

Most of these SFR registers are also accessible in external RAM space, at the addresses shown in Table 15-3.

Table 15-3. SFR Registers and External Ram Equivalent

SFR Register Name	Hex	External Ram Register Address and Name	
AUTODATA1	9C	E67B	XAUTODAT1
AUTODATA2	9F	E67C	XAUTODATQ2
EP2468STAT	AA	E6A3-E6A6	EPxCS
EP24FIFOFLGS	AB	E6A7-E6AA	EPxFIFOFLGS
EP68FIFOFLGS	AC		
EP01STAT	BA	E6A0-E6A2	EP0CS, EP1OUTCS, EP1INCS
GPIFTRIG	BB	E6D4, E6DC, E6E4, E6EC	EPxGPIFTRIG
GPIFSGLDATH	BD	E6F0	XGPIFSGLDATH
GPIFSGLDATLX	BE	E6F1	XGPIFSGLDATLX
GPIFSGLDATLNOX	BF	E6F2	XGPIFSGLDATLNOX

## 15.4 GPIF Waveform Memories

### 15.4.1 GPIF Waveform Descriptor Data

**WAVEDATA**                      **GPIF Waveform Descriptor 0, 1, 2, 3**                      **E400-E47F\***  
**Data**

b7	b6	b5	b4	b3	b2	b1	b0
<b>D7</b>	<b>D6</b>	<b>D5</b>	<b>D4</b>	<b>D3</b>	<b>D2</b>	<b>D1</b>	<b>D0</b>
R/W	R/W	R/W	R/W	R/W	R/W	R/W	R/W
x	x	x	x	x	x	x	x

\*Accessible only when IFCFG1:0 = 10.

Figure 15-6. GPIF Waveform Descriptor Data

The four GPIF waveform descriptor tables are stored in this space. See *Chapter 10 "General Programmable Interface (GPIF)"* for details.

## 15.5 General Configuration Registers

### 15.5.1 CPU Control and Status

**CPUCS**                                      **CPU Control and Status**                                      **E600**

b7	b6	b5	b4	b3	b2	b1	b0
<b>0</b>	<b>0</b>	<b>PORTCSTB</b>	<b>CLKSPD1</b>	<b>CLKSPD0</b>	<b>CLKINV</b>	<b>CLKOE</b>	<b>0</b>
R	R	R/W	R	R	R	R/W	R
0	0	0	1	0	0	1	0

Figure 15-7. CPU Control and Status

**Bit 5**                      **PORTCSTB**                      *PORTC access generates  $\overline{RD}$  and  $\overline{WR}$  strobes*

The 100- and 128-pin FX2 packages have two output pins,  $\overline{RD}$  and  $\overline{WR}$ , that can be used to synchronize data transfers on I/O PORTC. When PORTCSTB=1, this feature is enabled. Any read of PORTC activates a  $\overline{RD}$  strobe, and any write to PORTC activates a  $\overline{WR}$  strobe.

The  $\overline{RD}$  and  $\overline{WR}$  strobes are asserted for two CLKOUT cycles; the  $\overline{WR}$  strobe asserts two CLKOUT cycles after the PORTC pins are updated.

If a design uses the 128-pin FX2 and connects off-chip memory to the address and data buses, this bit should be set to zero. This is because the  $\overline{RD}$  and  $\overline{WR}$  pins are also the standard strobes used to read and write off-chip memory, so normal reads/writes to I/O Port C would disrupt normal accesses to that memory.

**Bit 4-3**                      **CLKSPD1:0**                                      *CPU Clock Speed*

*Table 15-4. CPU Clock Speeds*

CLKSPD1	CLKSPD0	CPU Clock
0	0	12 MHz (Default)
0	1	24 MHz
1	0	48 MHz
1	1	Reserved

These bits set the CPU clock speed. At power-on-reset, these bits default to 00 (12 MHz). Firmware may modify these bits at any time.

**Bit 2**                      **CLKINV**    *Invert CLKOUT Signal*

CLKINV=0: CLKOUT signal not inverted (as shown in all timing diagrams).

CLKINV=1: CLKOUT signal inverted.

**Bit 1**                      **CLKOE**    *Drive CLKOUT Pin*

CLKOE=1: CLKOUT pin driven.

CLKOE=0: CLKOUT pin floats.

**15.5.2 Interface Configuration (Ports, GPIF, slave FIFOs)**

**IFCONFIG**                      **Interface Configuration(Ports, GPIF, slave FIFOs)**                      **E601**

b7	b6	b5	b4	b3	b2	b1	b0
<b>IFCLKSRC</b>	<b>3048MHZ</b>	<b>IFCLKOE</b>	<b>IFCLKPOL</b>	<b>ASYNC</b>	<b>GSTATE</b>	<b>IFCFG1</b>	<b>IFCFG0</b>
R/W	R/W	R/W	R/W	R/W	R/W	R/W	R/W
1	1	0	0	0	0	0	0

*Figure 15-8. Interface Configuration (Ports, GPIF, slave FIFOs)*



**Bit 7**                      **IFCLKSRC**                      *FIFO/GPIF Clock Source*

This bit selects the clock source for both the FIFOS and GPIF. If IFCLKSRC=0, the external clock on the IFCLK pin is selected. If IFCLKSRC=1, an internal 30- or 48-MHz clock is used.

**Bit 6**                      **3048MHZ**                      *Internal FIFO/GPIF Clock Frequency*

*Table 15-5. Internal FIFO/GPIF Clock Frequency*

3048MHZ	FIFO & GPIF Clock
0	30 MHz
1	48 MHz

This bit selects the internal FIFO & GPIF clock frequency.

**Bit 5**                      **IFCLKOE**                      *IFCLK pin output enable*

0=Tri-state

1=Drive

**Bit 4**                      **IFCLKPOL**                      *Invert the IFCLK signal*

This bit indicates that the IFCLK signal is inverted.

When IFCLKPOL=0, the clock has the polarity shown in all the timing diagrams in this manual. When IFCLKPOL=1, the clock is inverted.

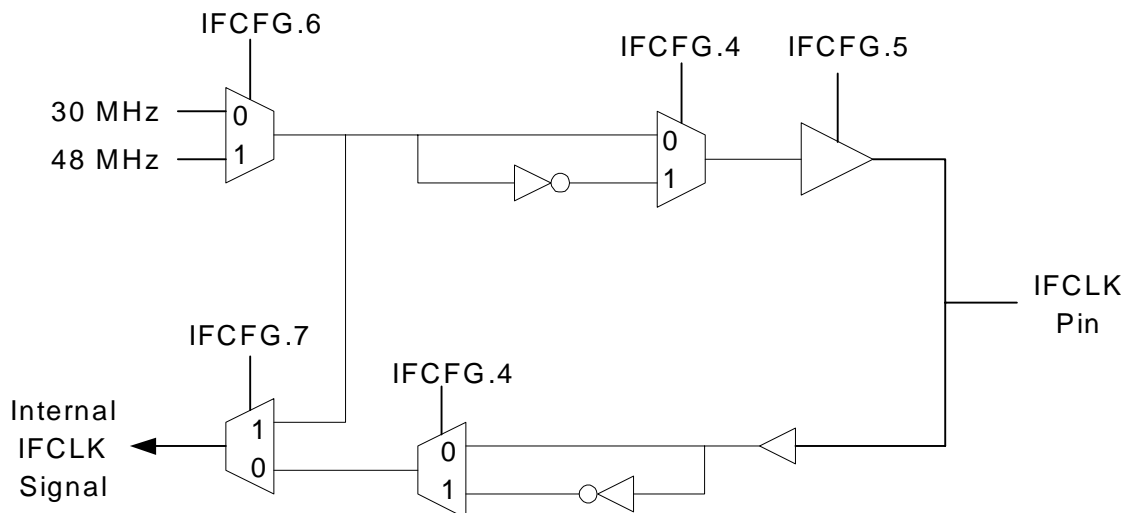

*Figure 15-9. IFCLK Configuration*

**Bit 3**                      **ASYNC**                      *Slave FIFO Asynchronous Mode*

This bit applies only when the FX2 is operating in Slave FIFO mode (i.e., IFCFG1:0 = 11).

When ASYNC=0, the FIFOs operate synchronously: a clock is supplied either internally or externally on the IFCLK pin; the FIFO control signals function as read and write enable signals for the clock signal.

When ASYNC=1, the FIFOs operate asynchronously: no clock signal input to IFCLK is required; the FIFO control signals function directly as read and write strobes.

**Bit 2**                      **GSTATE**                      *Drive GSTATE x on Port x*

When GSTATE=1, three bits in Port E take on the signals shown in Table 15-6. The GSTATE bits, which indicate GPIF states, are used for diagnostic purposes.

*Table 15-6. Port E Alternate Functions When GSTATE=1*

IO Pin	Alternate Function
PE0	GSTATE[0]
PE1	GSTATE[1]
PE2	GSTATE[2]

**Bit 1-0**                      **IFCFG1:0**                      *Select Interface Mode (Ports, GPIF, or Slave FIFO)*

*Table 15-7. Ports, GPIF, Slave FIFO Select*

IFCFG1	IFCFG0	Configuration
0	0	Ports
0	1	reserved
1	0	GPIF Interface (internal master)
1	1	Slave FIFO Interface (external master)

These bits control the following FX2 interface signals, as shown in Table 15-8.

Table 15-8. IFCFG Selection of Port I/O Pin Functions

<b>IFCFG1:0 = 00 (Ports)</b>	<b>IFCFG1:0 = 10 (GPIF Master)</b>	<b>IFCFG1:0 = 11 (Slave FIFO)</b>
PD7	FD[15]	FD[15]
PD6	FD[14]	FD[14]
PD5	FD[13]	FD[13]
PD4	FD[12]	FD[12]
PD3	FD[11]	FD[11]
PD2	FD[10]	FD[10]
PD1	FD[9]	FD[9]
PD0	FD[8]	FD[8]
PB7	FD[7]	FD[7]
PB6	FD[6]	FD[6]
PB5	FD[5]	FD[5]
PB4	FD[4]	FD[4]
PB3	FD[3]	FD[3]
PB2	FD[2]	FD[2]
PB1	FD[1]	FD[1]
PB0	FD[0]	FD[0]
<b>INT0 / PA0</b>	<b>INT0 / PA0</b>	<b>INT0 / PA0</b>
<b>INT1 / PA1</b>	<b>INT1 / PA1</b>	<b>INT1 / PA1</b>
PA2	PA2	SLOE
<b>WU2 / PA3</b>	<b>WU2 / PA3</b>	<b>WU2 / PA3</b>
PA4	PA4	FIFOADR0
PA5	PA5	FIFOADR1
PA6	PA6	FIFOADR2
PA7	PA7	PA7 / FLAGD / $\overline{\text{SLCS}}$
<b>PC7:0</b>	<b>PC7:0</b>	<b>PC7:0</b>
<b>PE7:0</b>	<b>PE7:0</b>	<b>PE7:0</b>

Note: Signals shown in bold type do not change with IFCFG; they are shown for completeness.

### 15.5.3 Slave FIFO FLAGA-FLAGD Pin Configuration

<b>PINFLAGSAB</b> <i>see Section 15.14</i>	<b>Slave FIFO FLAGA and FLAGB Pin Configuration</b>	<b>E602</b>
---	---	-------------

b7	b6	b5	b4	b3	b2	b1	b0
<b>FLAGB3</b>	<b>FLAGB2</b>	<b>FLAGB1</b>	<b>FLAGB0</b>	<b>FLAGA3</b>	<b>FLAGA2</b>	<b>FLAGA1</b>	<b>FLAGA0</b>
R/W	R/W	R/W	R/W	R/W	R/W	R/W	R/W
0	0	0	0	0	0	0	0

<b>PINFLAGSCD</b> <i>see Section 15.14</i>	<b>Slave FIFO FLAGC and FLAGD Pin Configuration</b>	<b>E603</b>
---	---	-------------

b7	b6	b5	b4	b3	b2	b1	b0
<b>FLAGD3</b>	<b>FLAGD2</b>	<b>FLAGD1</b>	<b>FLAGD0</b>	<b>FLAGC3</b>	<b>FLAGC2</b>	<b>FLAGC1</b>	<b>FLAGC0</b>
R/W	R/W	R/W	R/W	R/W	R/W	R/W	R/W
0	1	0	0	0	0	0	0

Figure 15-10. Slave FIFO FLAGA-FLAGD Pin Configuration

FX2 has four FIFO flag output pins, FLAGA, FLAGB, FLAGC and FLAGD. These flags can be programmed to represent various FIFO flags using four select bits for each FIFO. The PINFLAGSAB register controls the FLAGA and FLAGB signals, and the PINFLAGSCD register controls the FLAGC and FLAGD signal. The 4-bit coding for all four flags is the same, as shown in Table 15-9. In the “FLAGx” notation, “x” can be A, B, C or D.

Table 15-9. FIFO Flag Pin Functions

FLAGx3	FLAGx2	FLAGx1	FLAGx0	Pin Function
0	0	0	0	FLAGA=PF, FLAGB=FF, FLAGC=EF, FLAGD=EP2PF (Actual FIFO is selected by FIFOADR[0,1] pins)
0	0	0	1	reserved
0	0	1	0	reserved
0	0	1	1	reserved
0	1	0	0	EP2 PF
0	1	0	1	EP4 PF
0	1	1	0	EP6 PF
0	1	1	1	EP8 PF
1	0	0	0	EP2 EF
1	0	0	1	EP4 EF
1	0	1	0	EP6 EF
1	0	1	1	EP8 EF
1	1	0	0	EP2 FF
1	1	0	1	EP4 FF
1	1	1	0	EP6 FF
1	1	1	1	EP8 FF

NOTE: FLAGD can only be fixed flags (for instance, it cannot index).

For the default (0000) selection, the four FIFO flags are indexed as shown in the first table entry. The input pins FIFOADR1 and FIFOADR0 select to which of the four FIFOs the flags correspond. These pins are decoded as follows:

Table 15-10. FIFOADR1 FIFOADR2 Flag Correspondence

FIFOADR1 pin	FIFOADR0 pin	Selected FIFO
0	0	EP2
0	1	EP4
1	0	EP6
1	1	EP8

For example, if FLAGA[3:0]=0000 and the FIFO address pins are driven to [01], then FLAGA is the EP4-Programmable Flag, FLAGB is the EP4-Full Flag, and FLAGC is the EP4-Empty Flag, and FLAGD defaults as PA7. Set PORTACFG.7 = 1 to use FLAGD which by default is EP2PF.

The other (non-zero) values of FLAGx[3:0] allow the designer to independently configure the four flag outputs FLAGA-FLAGD to correspond to any flag—Programmable, Full, or Empty—from any of the four endpoint FIFOs. This allows each flag to be assigned to any of the four FIFOs, including those not currently selected by the FIFOADDR pins. For example, external logic could be filling the EP2IN FIFO with data while also checking the full flag for the EP4OUT FIFO.

### 15.5.4 FIFO Reset

**FIFORESET**                      **Restore FIFOs to Default State**                      **E604**  
*see Section 15.14*

b7	b6	b5	b4	b3	b2	b1	b0
<b>NAKALL</b>	<b>x</b>	<b>x</b>	<b>x</b>	<b>x</b>	<b>x</b>	<b>x</b>	<b>x</b>
W	W	W	W	W	W	W	W
x	x	x	x	x	x	x	x

Figure 15-11. Restore FIFOs to Reset State

Write 0x80 to this register to NAK all transfers from the host, then write 0x02, 0x04, 0x06, or 0x08 to reset an individual FIFO (i.e., to restore endpoint FIFO flags and byte counts to their default states), then write 0x00 to restore normal operation.

### 15.5.5 Breakpoint, Breakpoint Address High, Breakpoint Address Low

**BREAKPT**                      **Breakpoint Control**                      **E605**

b7	b6	b5	b4	b3	b2	b1	b0
<b>0</b>	<b>0</b>	<b>0</b>	<b>0</b>	<b>BREAK</b>	<b>BPPULSE</b>	<b>BPEN</b>	<b>0</b>
R	R	R	R	R/W	R/W	R/W	R
0	0	0	0	0	0	0	0

Figure 15-12. Breakpoint Control

**Bit 3**                      **Break**                      *Enable Breakpoint*

The BREAK bit is set when the CPU address bus matches the address held in the bit breakpoint address registers (E606/07). The BKPT pin reflects the state of this bit. Write a “1” to the BREAK bit to clear it. It is not necessary to clear the BREAK bit if the pulse mode bit (BPPULSE) is set.

**Bit 2**                      **BPPULSE**                      *Breakpoint Pulse Mode*

Set this bit to “1” to pulse the BREAK bit (and BKPT pin) high for 8 CLKOUT cycles when the 8051 address bus matches the address held in the breakpoint address registers. When this bit is set to “0”, the BREAK bit (and BKPT pin) remains high until it is cleared by firmware.

**Bit 1**                      **BPEN**

*Breakpoint Enable*

If this bit is “1”, a BREAK signal is generated whenever the 16-bit address lines match the value in the Breakpoint Address Registers (BPADDRH:L). The behavior of the BREAK bit and associated BKPT pin signal is either latched or pulsed, depending on the state of the BPPULSE bit.

**BPADDRH**                      **Breakpoint Address High**                      **E606**

b7	b6	b5	b4	b3	b2	b1	b0
<b>A15</b>	<b>A14</b>	<b>A13</b>	<b>A12</b>	<b>A11</b>	<b>A10</b>	<b>A9</b>	<b>A8</b>
R/W	R/W	R/W	R/W	R/W	R/W	R/W	R/W
x	x	x	x	x	x	x	x

*Figure 15-13. Breakpoint Address High*

**BPADDRL**                      **Breakpoint Address Low**                      **E607**

b7	b6	b5	b4	b3	b2	b1	b0
<b>A7</b>	<b>A6</b>	<b>A5</b>	<b>A4</b>	<b>A3</b>	<b>A2</b>	<b>A1</b>	<b>A0</b>
R/W	R/W	R/W	R/W	R/W	R/W	R/W	R/W
x	x	x	x	x	x	x	x

*Figure 15-14. Breakpoint Address Low*

**Bit 15-0**                      **A15:0**                      *High and Low Breakpoint Address*

When the current 16-bit address (code or XDATA) matches the BPADDRH/BPADDRL address, a breakpoint event occurs. The BPPULSE and BPEN bits in the BREAKPT register control the action taken on a breakpoint event.

### 15.5.6 230 Kbaud Clock (T0, T1, T2)

#### UART230                      230 KBaud clock for T1                      E608

b7	b6	b5	b4	b3	b2	b1	b0
<b>0</b>	<b>0</b>	<b>0</b>	<b>0</b>	<b>0</b>	<b>0</b>	<b>230UART1</b>	<b>230UART0</b>
R	R	R	R	R	R	R/W	R/W
0	0	0	0	0	0	0	0

Figure 15-15. 230 Kbaud Internally Generated Reference Clock

#### Bit 1- 0                      230UARTx                      Set 230 KBaud Operation

Setting these bits to 1 overrides the timer inputs to the UARTs, and UART0 and UART1 will use the 230 KBaud clock rate. This mode provides the correct frequency to the UART regardless of the CPU clock frequency (12, 24, or 48 MHz).

### 15.5.7 Slave FIFO Interface Pins Polarity

#### FIFOPINPOLAR                      Slave FIFO Interface Pins Polarity                      E609 see Section 15.14

b7	b6	b5	b4	b3	b2	b1	b0
<b>0</b>	<b>0</b>	<b>PKTEND</b>	<b>SLOE</b>	<b>SLRD</b>	<b>SLWR</b>	<b>EF</b>	<b>FF</b>
R	R	R/W	R/W	R/W	R/W	R/W	R/W
0	0	0	0	0	0	0	0

Figure 15-16. Slave FIFO Interface Pins Polarity

#### Bit 5                      PKTEND                      FIFO Packet End Polarity

This bit selects the polarity of the PKTEND FIFO input pin. 0 selects the polarity shown in the data sheet (active low). 1 selects active high.

#### Bit 4                      SLOE                      FIFO Output Enable Polarity

This bit selects the polarity of the SLOE FIFO input pin. 0 selects the polarity shown in the data sheet (active low). 1 selects active high.



**Bit 3**                      **SLRD**                                      *FIFO Read Polarity*

This bit selects the polarity of the SLRD FIFO input pin. 0 selects the polarity shown in the data sheet (active low). 1 selects active high.

**Bit 2**                      **SLWR**                                      *FIFO Write Polarity*

This bit selects the polarity of the SLWR FIFO input pin. 0 selects the polarity shown in the data sheet (active low). 1 selects active high.

**Bit 1**                      **EF**    *Empty Flag Polarity*

This bit selects the polarity of the SLWR FIFO output pin. 0 selects the polarity shown in the data sheet (active low). 1 selects active high.

**Bit 0**                      **FF**    *Full Flag Polarity*

This bit selects the polarity of the SLWR FIFO output pin. 0 selects the polarity shown in the data sheet (active low). 1 selects active high.

### 15.5.8 Chip Revision ID

REVID								Chip Revision ID								E60A	
b7		b6		b5		b4		b3		b2		b1		b0			
<b>RV7</b>		<b>RV6</b>		<b>RV5</b>		<b>RV4</b>		<b>RV3</b>		<b>RV2</b>		<b>RV1</b>		<b>RV0</b>			
R		R		R		R		R		R		R		R			
0		0		0		0		0		0		0		0			

Figure 15-17. Chip Revision ID

**Bit 7-0**                      **RV7:0**                                      *Chip Revision Number*

These register bits define the silicon revision. Consult individual Cypress Semiconductor data sheets for values.

## 15.5.9 GPIF Hold Time

### GPIFHOLDTIME E60C

b7	b6	b5	b4	b3	b2	b1	b0
0	0	0	0	0	0	HOLDTIME[1:0]	
R	R	R	R	R	R	RW	RW
0	0	0	0	0	0	0	0

For any transaction where the GPIF writes data onto FD[15:0], this register determines how long the data is held. Valid choices are 0, ½ or 1 IFCLK cycle. This register applies to *any* data written by the GPIF to FD[15:0], whether through a flow state or not.

For non-flow states, the hold amount is really just a delay of the normal (non-held) presentation of FD[15:0] by the amount specified in HOLDTIME[1:0].

For flow states in which the GPIF is the master on the bus (FLOWSTB.SLAVE = 0), the hold amount is with respect to the activating edge (see FLOW\_MASTERSTB\_EDGE) of Master Strobe (which will be a CTL pin in this case).

For flow states in which the GPIF is the slave on the bus (FLOWSTB.SLAVE = 1), the hold amount is really just a delay of the normal (non-held) presentation of FD[15:0] by the amount specified in HOLDTIME[1:0] in reaction to the activating edge of Master Strobe (which will be a RDY pin in this case). Note the hold amount is NOT *directly* with respect to the activating edge of Master Strobe in this case. It is with respect to when the data would normally come out in response to Master Strobe including any latency to synchronize Master Strobe.

In all cases, the data will be held for the desired amount even if the ensuing GPIF state calls for the data bus to be tristated. In other words the FD[15:0] output enable will be held by the same amount as the data itself.

**Bits 1-0**                      **HOLDTIME[1:0]**                      *GPIF Hold Time*

00 = 0 IFCLK cycles

01 = ½ IFCLK cycle

10 = 1 IFCLK cycle

11 = reserved

## 15.6 Endpoint Configuration

### 15.6.1 Endpoint 1-OUT/Endpoint 1-IN Configurations

<b>EP1OUTCFG</b>	<b>Endpoint 1-OUT Configuration</b>	<b>E610</b>
<b>EP1INCFG</b>	<b>Endpoint 1-IN Configuration</b>	<b>E611</b>

b7	b6	b5	b4	b3	b2	b1	b0
<b>VALID</b>	<b>0</b>	<b>TYPE1</b>	<b>TYPE0</b>	<b>0</b>	<b>0</b>	<b>0</b>	<b>0</b>
R/W	R	R/W	R/W	R	R	R	R
1	0	1	0	0	0	0	0

Figure 15-18. Endpoint 1-OUT/Endpoint 1-IN Configurations

**Bit 7**                      **VALID**    *Activate an Endpoint*

Set VALID=1 to activate an endpoint, and VALID=0 to de-activate it. All FX2 endpoints default to VALID. An endpoint whose VALID bit is 0 does not respond to any USB traffic.

**Bit 5-4**                      **TYPE1:0**    *Defines the Endpoint Type*

These bits define the endpoint type, as shown in the table below.

Table 15-11. Endpoint Type Definitions

TYPE1	TYPE0	Endpoint Type
0	0	Invalid
0	1	Invalid
1	0	BULK (default)
1	1	INTERRUPT

## 15.6.2 Endpoint 2, 4, 6 and 8 Configuration

### EP2CFG Endpoint 2 Configuration E612

b7	b6	b5	b4	b3	b2	b1	b0
<b>VALID</b>	<b>DIR</b>	<b>TYPE1</b>	<b>TYPE0</b>	<b>SIZE</b>	<b>0</b>	<b>BUF1</b>	<b>BUF0</b>
R/W	R/W	R/W	R/W	R/W	R	R/W	R/W
1	0	1	0	0	0	1	0

Figure 15-19. Endpoint 2 Configuration

### EP4CFG Endpoint 4 Configuration E613

b7	b6	b5	b4	b3	b2	b1	b0
<b>VALID</b>	<b>DIR</b>	<b>TYPE1</b>	<b>TYPE0</b>	<b>0</b>	<b>0</b>	<b>0</b>	<b>0</b>
R/W	R/W	R/W	R/W	R	R	R	R
1	0	1	0	0	0	0	0

Figure 15-20. Endpoint 4 Configuration

### EP6CFG Endpoint 6 Configuration E614

b7	b6	b5	b4	b3	b2	b1	b0
<b>VALID</b>	<b>DIR</b>	<b>TYPE1</b>	<b>TYPE0</b>	<b>SIZE</b>	<b>0</b>	<b>BUF1</b>	<b>BUF0</b>
R/W	R/W	R/W	R/W	R/W	R	R/W	R/W
1	1	1	0	0	0	1	0

Figure 15-21. Endpoint 6 Configuration

### EP8CFG Endpoint 8 Configuration E615

b7	b6	b5	b4	b3	b2	b1	b0
<b>VALID</b>	<b>DIR</b>	<b>TYPE1</b>	<b>TYPE0</b>	<b>0</b>	<b>0</b>	<b>0</b>	<b>0</b>
R/W	R/W	R/W	R/W	R	R	R	R
1	1	1	0	0	0	0	0

Figure 15-22. Endpoint 8 Configuration

These registers configure the large, data-handling FX2 endpoints.

**Bit 7**                      **VALID**                                      *Activate an Endpoint*

Set VALID=1 to activate an endpoint, and VALID=0 to de-activate it. All FX2 endpoints default to valid. An endpoint whose VALID bit is 0 does not respond to any USB traffic.

**Bit 6**                      **DIR**    *Sets Endpoint Direction*

0 = OUT, 1 = IN

**Bit 5-4**                      **TYPE**    *Defines the Endpoint Type*

These bits define the endpoint type, as shown in the table below. The TYPE bits apply to all of the large-endpoint configuration registers.

*Table 15-12. Endpoint Type Definitions*

TYPE1	TYPE0	Endpoint Type
0	0	Invalid
0	1	ISOCHRONOUS
1	0	BULK (default)
1	1	INTERRUPT

**Bit 3**                      **SIZE**    *Sets Size of Endpoint Buffer*

0 = 512 bytes, 1 = 1024 bytes

Endpoints 4 and 8 can only be 512 bytes. Endpoints 2 and 6 are selectable.

**Bit 1-0**                      **BUF**    *Buffering Type/Amount*

The amount of endpoint buffering is presented in Table 15-13.

*Table 15-13. Endpoint Buffering Amounts*

BUF1	BUF0	Buffering
0	0	Quad
0	1	Invalid
1	0	Double
1	1	Triple

### 15.6.3 Endpoint 2, 4, 6 and 8/Slave FIFO Configuration

<b>EP2FIFOCFG</b> <i>see Section 15.14</i>	<b>Endpoint 2/Slave FIFO Configuration</b>	<b>E618</b>
<b>EP4FIFOCFG</b> <i>see Section 15.14</i>	<b>Endpoint 4/Slave FIFO Configuration</b>	<b>E619</b>
<b>EP6FIFOCFG</b> <i>see Section 15.14</i>	<b>Endpoint 6/Slave FIFO Configuration</b>	<b>E61A</b>
<b>EP8FIFOCFG</b> <i>see Section 15.14</i>	<b>Endpoint 8/Slave FIFO Configuration</b>	<b>E61B</b>

b7	b6	b5	b4	b3	b2	b1	b0
<b>0</b>	<b>INFM1</b>	<b>OEP1</b>	<b>AUTOOUT</b>	<b>AUTOIN</b>	<b>ZEROLENIN</b>	<b>0</b>	<b>WORDWIDE</b>
R	R/W	R/W	R/W	R/W	R/W	R	R/W
0	0	0	0	0	1	0	1

Figure 15-23. Endpoint 2, 4, 6 and 8 /Slave FIFO Configuration

#### Bit 6 **INFM1** *IN Full Minus One*

When a FIFO configuration register's 'INEARLY' or INFM bit is set to 1, the FIFO flags for that endpoint become valid one sample earlier than when the FULL condition occurs. These bits take effect only when the FIFOS are operating synchronously—according to an internally- or externally-supplied clock. Having the FIFO flag indications a clock early simplifies some synchronous interfaces (applies **only** to IN endpoints).

#### Bit 5 **OEP1** *OUT Empty Plus One*

When a FIFO configuration register's 'OUTEARLY' or OEP1 bit is set to 1, the FIFO flags for that endpoint become valid one sample earlier than when the EMPTY condition occurs. These bits take effect only when the FIFOS are operating synchronously—according to an internally- or externally-supplied clock. Having the FIFO flag indications a clock early simplifies some synchronous interfaces (applies **only** to OUT endpoints).

#### Bit 4 **AUTOOUT** *Instantaneous Connection to Endpoint FIFO*

This bit applies only to OUT endpoints.

When AUTOOUT=1, as soon as a buffer fills with USB data, the buffer is automatically and instantaneously committed to the endpoint FIFO bypassing the CPU. The endpoint FIFO flags and buffer counts immediately indicate the change in FIFO status.

When AUTOOUT=0, as soon as a buffer fills with USB data, an endpoint interrupt is asserted. The connection of the buffer to the endpoint FIFO is under control of the firmware, rather than

automatically being connected. Using this method, the firmware can inspect the data in OUT packets, and based on what it finds, choose to include that packet in the endpoint FIFO or not. The firmware can even modify the packet data, and then commit it to the endpoint FIFO.

The SKIP bit (in the EPxBCL registers) chooses between skipping and committing packet data.

**Bit 3**    **AUTOIN**    *Auto Commit to SIE*

This bit applies only to IN endpoints.

FX2 has EPxAUTOINLEN registers that allow the firmware to configure endpoints to sizes smaller than the physical memory sizes used to implement the endpoint buffers (512 or 1024 bytes). For example, suppose the firmware configures the EP2 buffer to be 1024 bytes, and then sets up EP2 as a 760-byte endpoint by setting EP2AUTOINLEN=760 (this must match the wMaxPacketSize value in the endpoint descriptor). This makes EP2 appear to be a 760-byte endpoint to the USB host, even though EP2's physical buffer is 1024 bytes.

When AUTOIN=1, FX2 automatically packetizes and dispatches IN packets according to the packet length value it finds in the EPxAUTOINLEN registers. In this example, the GPIF (or an external master, if the FX2 is in Slave FIFO mode) could load the EP2 buffer with 950 bytes, which the FX2 logic would then automatically send as two packets, of 760 and 190 bytes.

When AUTOIN=0, each packet has to be manually committed to SIE.

**Bit 2**    **ZEROLENIN**    *Enable Zero-length IN Packets*

When this flag is '1', a zero length packet will be sent when PKTEND is activated and there are no bytes in the current packet. If this flag is '0', zero length packets will not be sent on PKTEND.

**Bit 0**    **WORDWIDE**    *Select Byte/Word FIFOs on PORTB/D Pins*

This bit selects byte or word FIFOs on the PORTB and PORTD pins. The WORD bit applies "for IFCFG=11 or 10".

The OR of all 4 WORDWIDE bits is what causes PORTD to be PORTD or FD[15:8]. The individual WORDWIDE bits indicate how data will be passed for each individual endpoint.

### 15.6.4 Endpoint 2, 4, 6, 8 AUTOIN Packet Length (High/Low)

<b>EP2AUTOINLENH</b> <i>see Section 15.14</i>	<b>Endpoint 2 AUTOIN Packet Length</b> <b>HIGH</b>	<b>E620</b>
<b>EP6AUTOINLENH</b> <i>see Section 15.14</i>	<b>Endpoint 6 AUTOIN Packet Length</b> <b>HIGH</b>	<b>E624</b>

b7	b6	b5	b4	b3	b2	b1	b0
<b>0</b>	<b>0</b>	<b>0</b>	<b>0</b>	<b>0</b>	<b>PL10</b>	<b>PL9</b>	<b>PL8</b>
R	R	R	R	R	R/W	R/W	R/W
0	0	0	0	0	0	1	0

Figure 15-24. Endpoint 2 and 6 AUTOIN Packet Length High

**Bit 2-0**                      **PL10:8**                                      *Packet Length High*  
 High three bits of Packet Length.

<b>EP4AUTOINLENH</b> <i>see Section 15.14</i>	<b>Endpoint 4 AUTOIN Packet Length</b> <b>HIGH</b>	<b>E622</b>
<b>EP8AUTOINLENH</b> <i>see Section 15.14</i>	<b>Endpoint 8 AUTOIN Packet Length</b> <b>HIGH</b>	<b>E626</b>

b7	b6	b5	b4	b3	b2	b1	b0
<b>0</b>	<b>0</b>	<b>0</b>	<b>0</b>	<b>0</b>	<b>0</b>	<b>PL9</b>	<b>PL8</b>
R	R	R	R	R	R	R/W	R/W
0	0	0	0	0	0	1	0

Figure 15-25. Endpoint 4 and 8 AUTOIN Packet Length High

**Bit 1-0**                      **PL9:8**                                      *Packet Length High*  
 High two bits of Packet Length.



<b>EP2AUTOINLENL</b> <i>see Section 15.14</i>	<b>Endpoint 2 AUTOIN Packet Length LOW</b>	<b>E621</b>
<b>EP4AUTOINLENL</b> <i>see Section 15.14</i>	<b>Endpoint 4 AUTOIN Packet Length LOW</b>	<b>E623</b>
<b>EP6AUTOINLENL</b> <i>see Section 15.14</i>	<b>Endpoint 6 AUTOIN Packet Length LOW</b>	<b>E625</b>
<b>EP8AUTOINLENL</b> <i>see Section 15.14</i>	<b>Endpoint 8 AUTOIN Packet Length LOW</b>	<b>E627</b>

b7	b6	b5	b4	b3	b2	b1	b0
<b>PL7</b>	<b>PL6</b>	<b>PL5</b>	<b>PL4</b>	<b>PL3</b>	<b>PL2</b>	<b>PL1</b>	<b>PL0</b>
R/W	R/W	R/W	R/W	R/W	R/W	R/W	R/W
0	0	0	0	0	0	0	0

Figure 15-26. Endpoint 2, 4, 6, 8 AUTOIN Packet Length Low

**Bit 7-0**

**PL7:0**

*Packet Length Low*

Low eight bits of packet length.

These registers can be used to set smaller packet sizes than the physical buffer size (refer to the previously described EPxCFG registers). The default packet size is 512 bytes for all endpoints. Note that EP2 and EP6 can have maximum sizes of 1024 bytes, and EP4 and EP8 can have maximum sizes of 512 bytes, to be consistent with the endpoint structure.

**15.6.5 Endpoint 2, 4, 6, 8/Slave FIFO Programmable-Level Flag (High/Low)**

**EP2FIFOPFH**      **Endpoint 2/Slave FIFO Programmable-Level Flag HIGH**      **E630**  
*see Section 15.14*      **[HIGH SPEED (480 Mbit/Sec) Mode and FULL-SPEED (12 Mbit/Sec) Iso Mode]**

b7	b6	b5	b4	b3	b2	b1	b0
<b>DECIS</b>	<b>PKTSTAT</b>	<b>IN: PKTS[2] OUT:PFC12</b>	<b>IN: PKTS[1] OUT:PFC11</b>	<b>IN: PKTS[0] OUT:PFC10</b>	<b>0</b>	<b>PFC9</b>	<b>PFC8</b>
R/W	R/W	R/W	R/W	R/W	R	R/W	R/W
1	0	0	0	1	0	0	0

**EP2FIFOPFH**      **Endpoint 2/Slave FIFO Programmable-Level Flag HIGH**      **E630**  
*see Section 15.14*      **[FULL SPEED (12 Mbit/Sec) Non-Iso Mode]**

b7	b6	b5	b4	b3	b2	b1	b0
<b>DECIS</b>	<b>PKTSTAT</b>	<b>OUT:PFC12</b>	<b>OUT:PFC11</b>	<b>OUT:PFC10</b>	<b>0</b>	<b>PFC9</b>	<b>IN: PKTS[2] OUT:PFC8</b>
R/W	R/W	R/W	R/W	R/W	R	R/W	R/W
1	0	0	0	1	0	0	0

Figure 15-27. Endpoint 2/Slave FIFO Programmable Flag High

**EP6FIFOPFH**                      **Endpoint 6/Slave FIFO Programmable-Level**                      **E634**  
*see Section 15.14*                      **Flag HIGH**  
**[HIGH SPEED (480 Mbit/Sec) Mode and**  
**FULL-SPEED (12 Mbit/Sec) Iso Mode]**

b7	b6	b5	b4	b3	b2	b1	b0
<b>DECIS</b>	<b>PKTSTAT</b>	<b>IN: PKTS[2] OUT:PFC12</b>	<b>IN: PKTS[1] OUT:PFC11</b>	<b>IN: PKTS[0] OUT:PFC10</b>	<b>0</b>	<b>PFC9</b>	<b>PFC8</b>
R/W	R/W	R/W	R/W	R/W	R/W	R/W	R/W
0	0	0	0	1	0	0	0

**EP6FIFOPFH**                      **Endpoint 6/Slave FIFO Programmable-Level**                      **E634**  
*see Section 15.14*                      **Flag HIGH**  
**[FULL SPEED (12 Mbit/Sec) Non-Iso Mode]**

b7	b6	b5	b4	b3	b2	b1	b0
<b>DECIS</b>	<b>PKTSTAT</b>	<b>OUT:PFC12</b>	<b>OUT:PFC11</b>	<b>OUT:PFC10</b>	<b>0</b>	<b>PFC9</b>	<b>IN: PKTS[2] OUT:PFC8</b>
R/W	R/W	R/W	R/W	R/W	R/W	R/W	R/W
0	0	0	0	1	0	0	0

Figure 15-28. Endpoint 6/Slave FIFO Programmable Flag High

These registers control the point at which the programmable flag (PF) is asserted for each of the four endpoint FIFOs. The EPxFIFOPFH:L fields are interpreted differently for OUT and IN endpoints.

The threshold point for the programmable-level flag (PF) is configured as follows:

Each FIFO's programmable-level flag (PF) asserts when the FIFO reaches a user-defined fullness threshold. That threshold is configured as follows:

1. For OUT packets: The threshold is stored in PFC12:0. The PF is asserted when the number of bytes *in the entire FIFO* is less than/equal to (DECIS=0) or greater than/equal to (DECIS=1) the threshold.
2. For IN packets, with PKTSTAT = 1: The threshold is stored in PFC9:0. The PF is asserted when the number of bytes written into *the current, not-yet-committed packet in the FIFO* is less than/equal to (DECIS=0) or greater than/equal to (DECIS=1) the threshold.
3. For IN packets, with PKTSTAT = 0: The threshold is stored in two parts: PKTS2:0 holds the number of committed packets, and PFC9:0 holds the number of bytes in the current, not-yet-committed packet. The PF is asserted when the FIFO is at or less full than (DECIS=0), or at or more full than (DECIS=1), the threshold.

By default, FLAGA is the Programmable-Level Flag (PF) for the endpoint currently pointed to by the FIFOADR[1:0] pins. For EP2 and EP4, the default endpoint configuration is BULK, OUT, 512, 2x, and the PF pin asserts when the entire FIFO has greater than/equal to 512 bytes. For EP6 and EP8, the default endpoint configuration is BULK, IN, 512, 2x, and the PF pin asserts when the entire FIFO has less than/equal to 512 bytes.

In other words, the default-configuration PFs for EP2 and EP4 assert when the FIFOs are half-full, and the default-configuration PFs for EP6 and EP8 assert when those FIFOs are half-empty.

In the first example below, bits 5-3 have data that is required to complete the transfer. In the second example, bits 5-3 do not matter - those bits are don't cares because PKTSTAT=1:

### Example 1:

Assume a Bulk IN transfer over Endpoint 2 and PKTSTAT=0:

**EP2FIFOPFH = 0001 0000**

- b6=0 (or PKTSTAT=0): this indicates that the transfer will include packets (as defined by bits 5, 4, and 3) plus bytes (the sum in the flag low register)
- **b5b4b3=010** binary (or 2 decimal): this indicates the number of packets to expect during the transfer (in this case, two packets...)

**EP2FIFOPFL = 0011 0010**

- ...plus 50 bytes in the currently filling packet  
(the sum of the binary bits in the EP2FIFOPFL register is  $2 + 16 + 32 = 50$  decimal)

DECIS=0, thus PF activates when less than 2 PKTS+50 bytes.

### Example 2:

To perform an IN transfer of a number over the same endpoint, set PKTSTAT=1 and write a value into the EP2FIFOPFL register:

**EP2FIFOPFH = 01xxx000**

**EP2FIFOPFL = 75**

Setting PKTSTAT=1 causes the PF decision to be based on the byte count alone, ignoring the packet count. This mode is valuable for double-buffered endpoints, where only the byte count of the currently-filling packet is important.

DECIS=0, thus PF activates when less than 75 bytes in the current PKTS.

### Bit 1-0

### PFC9:8

### PF Threshold

Bits 1-0 of EP2FIFOPFH are bits 9-8 of the byte count register.

**EP4FIFOPFH**      **Endpoint 4/Slave FIFO Programmable-Level**      **E632**  
*see Section 15.14*      **Flag HIGH**  
**[HIGH SPEED (480 Mbit/Sec) Mode and**  
**FULL-SPEED (12 Mbit/Sec) Iso Mode]**

b7	b6	b5	b4	b3	b2	b1	b0
<b>DECIS</b>	<b>PKTSTAT</b>	<b>0</b>	<b>IN: PKTS[1] OUT:PFC10</b>	<b>IN: PKTS[0] OUT:PFC9</b>	<b>0</b>	<b>0</b>	<b>PFC8</b>
R/W	R/W	R	R/W	R/W	R	R	R/W
1	0	0	0	1	0	0	0

**EP4FIFOPFH**      **Endpoint 4/Slave FIFO Programmable-Level**      **E632**  
*see Section 15.14*      **Flag HIGH**  
**[FULL SPEED (12 Mbit/Sec) Non-Iso Mode]**

b7	b6	b5	b4	b3	b2	b1	b0
<b>DECIS</b>	<b>PKTSTAT</b>	<b>0</b>	<b>OUT:PFC10</b>	<b>OUT:PFC9</b>	<b>0</b>	<b>0</b>	<b>PFC8</b>
R/W	R/W	R	R/W	R/W	R	R	R/W
1	0	0	0	1	0	0	0

*Figure 15-29. Endpoint 4/Slave FIFO Programmable Flag High*

**EP8FIFOPFH**                      **Endpoint 8/Slave FIFO Programmable-Level**                      **E636**  
*see Section 15.14*                      **Flag HIGH**  
**[HIGH SPEED (480 Mbit/Sec) Mode and**  
**FULL-SPEED (12 Mbit/Sec) Iso Mode]**

b7	b6	b5	b4	b3	b2	b1	b0
<b>DECIS</b>	<b>PKTSTAT</b>	<b>0</b>	<b>IN: PKTS[1] OUT:PFC10</b>	<b>IN: PKTS[0] OUT:PFC9</b>	<b>0</b>	<b>0</b>	<b>PFC8</b>
R/W	R/W	R	R/W	R/W	R	R	R/W
0	0	0	0	1	0	0	0

**EP8FIFOPFH**                      **Endpoint 8/Slave FIFO Programmable-Level**                      **E636**  
*see Section 15.14*                      **Flag HIGH**  
**[FULL SPEED (12 Mbit/Sec) Non-Iso Mode]**

b7	b6	b5	b4	b3	b2	b1	b0
<b>DECIS</b>	<b>PKTSTAT</b>	<b>0</b>	<b>OUT:PFC10</b>	<b>OUT:PFC9</b>	<b>0</b>	<b>0</b>	<b>PFC8</b>
R/W	R/W	R	R/W	R/W	R	R	R/W
0	0	0	0	1	0	0	0

Figure 15-30. Endpoint 8/Slave FIFO Programmable Flag High

Refer to the discussion for EP2PF.

**Bit 7**                      **DECIS**                      *PF Polarity*

See EP2FIFOPFH and EP6FIFOPFH Register definition.

**Bit 6**                      **PKSTAT**                      *Packet Status*

See EP2FIFOPFH and EP6FIFOPFH Register definition.

**Bit 4-3**                      **PKTS1:0 / PFC10:9**                      *PF Threshold*

See EP2FIFOPFH and EP6FIFOPFH Register definition.

**Bit 0**                      **PFC8**                      *PF Threshold*

See EP2FIFOPFH and EP6FIFOPFH Register definition.

<b>EP2FIFOPFL</b> <i>see Section 15.14</i>	<b>Endpoint 2/Slave FIFO Prog. Flag LOW</b>	<b>E631</b>
<b>EP4FIFOPFL</b> <i>see Section 15.14</i>	<b>Endpoint 4/Slave FIFO Prog. Flag LOW</b>	<b>E633</b>
<b>EP6FIFOPFL</b> <i>see Section 15.14</i>	<b>Endpoint 6/Slave FIFO Prog. Flag LOW</b>	<b>E635</b>
<b>EP8FIFOPFL</b> <i>see Section 15.14</i>	<b>Endpoint 8/Slave FIFO Prog. Flag LOW [HIGH SPEED (480 Mbit/Sec) Mode and FULL-SPEED (12 Mbit/Sec) Iso Mode]</b>	<b>E637</b>

b7	b6	b5	b4	b3	b2	b1	b0
<b>PFC7</b>	<b>PFC6</b>	<b>PFC5</b>	<b>PFC4</b>	<b>PFC3</b>	<b>PFC2</b>	<b>PFC1</b>	<b>PFC0</b>
R/W	R/W	R/W	R/W	R/W	R/W	R/W	R/W
0	0	0	0	0	0	0	0

<b>EP2FIFOPFL</b> <i>see Section 15.14</i>	<b>Endpoint 2/Slave FIFO Prog. Flag LOW</b>	<b>E631</b>
<b>EP4FIFOPFL</b> <i>see Section 15.14</i>	<b>Endpoint 4/Slave FIFO Prog. Flag LOW</b>	<b>E633</b>
<b>EP6FIFOPFL</b> <i>see Section 15.14</i>	<b>Endpoint 6/Slave FIFO Prog. Flag LOW</b>	<b>E635</b>
<b>EP8FIFOPFL</b> <i>see Section 15.14</i>	<b>Endpoint 8/Slave FIFO Prog. Flag LOW [FULL SPEED (12 Mbit/Sec) Non-Iso Mode]</b>	<b>E637</b>

b7	b6	b5	b4	b3	b2	b1	b0
<b>IN: PKTS[1] OUT: PFC7</b>	<b>IN: PKTS[0] OUT: PFC6</b>	<b>PFC5</b>	<b>PFC4</b>	<b>PFC3</b>	<b>PFC2</b>	<b>PFC1</b>	<b>PFC0</b>
R/W	R/W	R/W	R/W	R/W	R/W	R/W	R/W
0	0	0	0	0	0	0	0

Figure 15-31. Endpoint 2, 4, 6, 8/Slave FIFO Programmable Flag Low

### Bit 7-0

### PFC7:0

### PF Threshold

This register contains the current packet bytes to be transferred when the EPx<sub>FIFOPFH</sub> register requires data.



Bits 9:8 of the byte count are in bits 1:0 of EP2<sub>FIFOPFH</sub>/EP6<sub>FIFOPFH</sub>.



Bit 8 of the byte count is bit 0 of EP4<sub>FIFOPFH</sub>/EP8<sub>FIFOPFH</sub>.

### 15.6.5.1 IN Endpoints

For IN endpoints, the Trigger registers can apply to either the full FIFO, comprising multiple packets, or only to the current packet being filled. The PKTSTAT bit controls this choice:

Table 15-14. Interpretation of PF for IN Endpoints

PKTSTAT	PF applies to:	EPxFIFOPFH:L format
0	PKTS + Current packet bytes	PKTS[ ] PBC[ ]
1	Current packet bytes only	PBC[ ]

#### Example 1:

The following is an example of how you might use the first case.

Assume a Bulk IN transfer over Endpoint 2. For Bulk transfers, the FX2 packet buffer size is 512 bytes. Assume you have reported a MaxPacketSize value of 100 bytes per packet, and you have configured the endpoint for triple-buffering. This means that whenever 100 bytes are loaded into a packet buffer, the FX2 logic commits that packet buffer to the USB interface, essentially adding 100 bytes to the “USB-side” FIFO.

You want to notify the external logic that is filling the endpoint FIFO under two conditions:

- Two of the three packet buffers are full (committed to sending over USB, but not yet sent).
- The current packet buffer is half-full.

In other words, all available IN endpoint buffer space is almost full. You accomplish this by setting:

**EP2FIFOPFH = 0001 0000**

- b6: PKTSTAT=0 to include packets plus bytes
- b5b4b3=2: two packets...

**EP2FIFOPFL = 0011 0010**

- ...plus 50 bytes in the currently filling packet



### Example 2:

If you want the PF to inform the outside interface (the logic that is filling the IN FIFO) whenever the current packet is 75% full, set PKTSTAT=1, and load a packet byte count of 75:

EP2FIFOPFH = 11xx000

EP2FIFOPFHL = 75

Setting PKTSTAT=1 causes the PF decision to be based on the byte count alone, ignoring the packet count. This mode is valuable for double-buffered endpoints, where only the byte count of the currently-filling packet is important.

### 15.6.5.2 OUT Endpoints

For OUT endpoints, the PF flag applies to the total number of bytes in the multi-packet FIFO, with no packet count field. Instead of representing byte counts in two segments, a packet count and a byte count for the currently emptying packet, the byte Trigger values indicate total bytes available in the FIFO. Note the discontinuity between PBC10 and PBC9.

Notice that the packet byte counts differ in the upper PBC bits because the endpoints support different FIFO sizes: The EP2 FIFO can be a maximum of 4096 bytes long, the EP6 FIFO can be a maximum of 2048 bytes long, and the EP4 and EP8 FIFOs can be a maximum of 1024 bytes long. The diagram below shows examples of the maximum FIFO sizes.

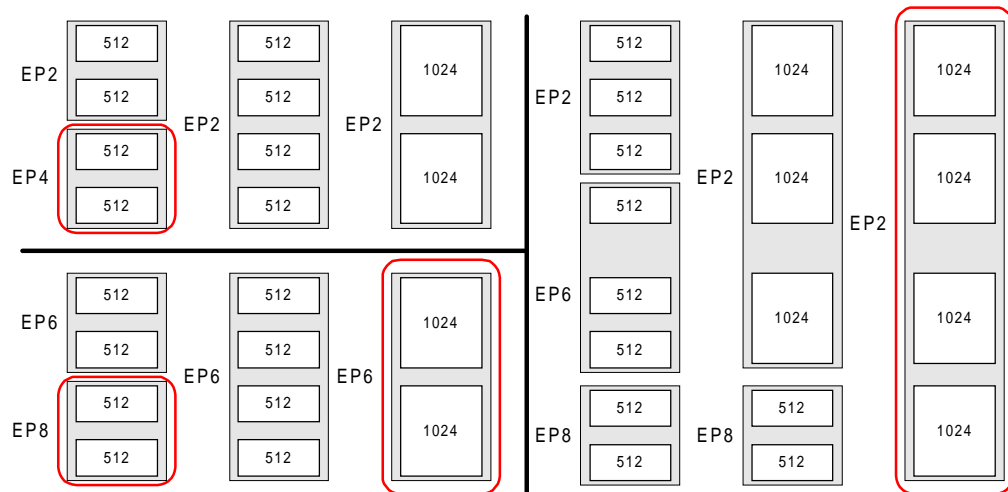

Figure 15-32. Maximum FIFO Sizes

### 15.6.6 Endpoint 2, 4, 6, 8 ISO IN Packets per Frame

<b>EP2ISOINPKTS</b>	<b>Endpoint 2 (if ISO) IN Packets Per Frame</b>	<b>E640</b>
<b>EP4ISOINPKTS</b>	<b>Endpoint 4 (if ISO) IN Packets Per Frame</b>	<b>E641</b>
<b>EP6ISOINPKTS</b>	<b>Endpoint 6 (if ISO) IN Packets Per Frame</b>	<b>E642</b>
<b>EP8ISOINPKTS</b>	<b>Endpoint 8 (if ISO) IN Packets Per Frame</b>	<b>E643</b>

b7	b6	b5	b4	b3	b2	b1	b0
<b>0</b>	<b>0</b>	<b>0</b>	<b>0</b>	<b>0</b>	<b>0</b>	<b>INPPF1</b>	<b>INPPF0</b>
R	R	R	R	R	R	R/W	R/W
0	0	0	0	0	0	0	1

Figure 15-33. Endpoint ISO IN Packets per Frame

#### Bit 1-0                      INPPF1:0                      IN Packets per Frame

For ISOCHRONOUS IN endpoints only, these bits determine the number of packets per micro-frame (high speed mode).

Table 15-15. IN Packets per Microframe

INPPF1	INPPF0	Packets
0	0	Invalid
0	1	1
1	0	2
1	1	3

### 15.6.7 Force IN Packet End

<b>INPKTEND</b>	<b>Force IN Packet End</b>	<b>E648</b>
<i>see Section 15.14</i>		

b7	b6	b5	b4	b3	b2	b1	b0
<b>0</b>	<b>0</b>	<b>0</b>	<b>0</b>	<b>EP3</b>	<b>EP2</b>	<b>EP1</b>	<b>EP0</b>
R/W	R/W	R/W	R/W	R/W	R/W	R/W	R/W
x	x	x	x	x	x	x	x

Figure 15-34. Force IN Packet End

**Bit 3-0**

**EP3:0**

*Arm the IN Transfer*

Duplicates the function of the PKTEND pin. This feature is used only for IN transfers.

By writing the desired endpoint number (2, 4, 6 or 8), FX2 logic automatically ‘dispatches’ an IN buffer, for example, it commits the packet to the USB logic, and writes the accumulated byte count to the endpoint’s byte count register, thus “arming” the IN transfer.

## 15.7 Interrupts

### 15.7.1 Endpoint 2, 4, 6, 8 Slave FIFO Flag Interrupt Enable/Request

<b>EP2FIFOIE</b> <i>see Section 15.14</i>	<b>EP2 Slave FIFO Flag Interrupt Enable (INT4)</b>	<b>E650</b>
<b>EP4FIFOIE</b> <i>see Section 15.14</i>	<b>EP4 Slave FIFO Flag Interrupt Enable (INT4)</b>	<b>E652</b>
<b>EP6FIFOIE</b> <i>see Section 15.14</i>	<b>EP6 Slave FIFO Flag Interrupt Enable (INT4)</b>	<b>E654</b>
<b>EP8FIFOIE</b> <i>see Section 15.14</i>	<b>EP8 Slave FIFO Flag Interrupt Enable (INT4)</b>	<b>E656</b>

b7	b6	b5	b4	b3	b2	b1	b0
<b>0</b>	<b>0</b>	<b>0</b>	<b>0</b>	<b>0</b>	<b>PF</b>	<b>EF</b>	<b>FF</b>
R/W	R/W	R/W	R/W	R/W	R/W	R/W	R/W
0	0	0	0	0	0	0	0

*Figure 15-35. Endpoint 2, 4, 6, 8 Slave FIFO Flag Interrupt Enable*

The Interrupt Registers control all the FX2 Interrupt Enables (IE) and Interrupt requests (IRQ). Interrupt enables and request bits for endpoint FIFO: Programmable Flag (PF), Empty Flag (EF), and Full Flag (FF).

To enable any of these interrupts, INTSETUP.1 (INT4SRC) and INTSETUP.0 must be ‘1’.

**Bit 2**

**PF**

*Programmable Flag*

When this bit is ‘1’, the programmable flag interrupt is enabled on INT4. When this bit is ‘0’ the programmable flag interrupt is disabled.

**Bit 1**                      **EF**                                      *Empty Flag*

When this bit is '1', the empty flag interrupt is enabled on INT4. When this bit is '0' the empty flag interrupt is disabled.

**Bit 0**                      **FF**                                      *Full Flag*

When this bit is '1', the full flag interrupt is enabled on INT4. When this bit is '0' the full flag interrupt is disabled.

<b>EP2FIFOIRQ</b> <i>see Section 15.14</i>	<b>EP2 Slave FIFO Flag Interrupt Request (INT4)</b>	<b>E651</b>
<b>EP4FIFOIRQ</b> <i>see Section 15.14</i>	<b>EP4 Slave FIFO Flag Interrupt Request (INT4)</b>	<b>E653</b>
<b>EP6FIFOIRQ</b> <i>see Section 15.14</i>	<b>EP6 Slave FIFO Flag Interrupt Request (INT4)</b>	<b>E655</b>
<b>EP8FIFOIRQ</b> <i>see Section 15.14</i>	<b>EP8 Slave FIFO Flag Interrupt Request (INT4)</b>	<b>E657</b>

b7	b6	b5	b4	b3	b2	b1	b0
<b>0</b>	<b>0</b>	<b>0</b>	<b>0</b>	<b>0</b>	<b>PF</b>	<b>EF</b>	<b>FF</b>
R/W	R/W	R/W	R/W	R/W	R/W	R/W	R/W
0	0	0	0	0	X	X	X

Figure 15-36. Endpoint 2, 4, 6, 8 Slave FIFO Flag Interrupt Request

Interrupt enables and request bits for endpoint FIFO: Programmable Flag (PF), Empty Flag (EF), and Full Flag (FF).

**Bit 2**                      **PF**                                      *Programmable Flag*

FX2 sets PF to 1 to indicate a “programmable flag” interrupt request. The interrupt source is available in the interrupt vector register IVEC4.

**Bit 1**                      **EF**                                      *Empty Flag*

FX2 sets EF to 1 to indicate an “empty flag” interrupt request. The interrupt source is available in the interrupt vector register IVEC4.

**Bit 0**
**FF**
*Full Flag*

FX2 sets FF to **1** to indicate a “full flag” interrupt request. The interrupt source is available in the interrupt vector register IVEC4.



*Do **not** clear an IRQ Bit by reading an IRQ Register, ORing its contents with a bit mask, and writing back the IRQ Register. This will clear ALL pending interrupts. Instead, simply write the bit mask value (with a “1” in the bit position of the IRQ you want to clear) directly to the IRQ Register.*

**15.7.2 IN-BULK-NAK Interrupt Enable/Request**
**IBNIE IN-BULK-NAK Interrupt Enable (INT2) E658**

b7	b6	b5	b4	b3	b2	b1	b0
<b>0</b>	<b>0</b>	<b>EP8</b>	<b>EP6</b>	<b>EP4</b>	<b>EP2</b>	<b>EP1</b>	<b>EP0</b>
R/W	R/W	R/W	R/W	R/W	R/W	R/W	R/W
0	0	0	0	0	0	0	0

*Figure 15-37. IN-BULK-NAK Interrupt Enable*

**IBNIRQ IN-BULK-NAK Interrupt Request (INT2) E659**

b7	b6	b5	b4	b3	b2	b1	b0
<b>0</b>	<b>0</b>	<b>EP8</b>	<b>EP6</b>	<b>EP4</b>	<b>EP2</b>	<b>EP1</b>	<b>EP0</b>
R/W	R/W	R/W	R/W	R/W	R/W	R/W	R/W
0	0	x	x	x	x	x	x

*Figure 15-38. IN-BULK-NAK Interrupt Request*

**Bit 5-0**
**EP[8,6,4,2,1,0]**
*Endpoint-Specific Interrupt Enable*

These interrupts occur when the host sends an IN token to a Bulk-IN endpoint which has not been loaded with data and armed for USB transfer. In this case the FX2 SIE automatically NAKs the IN token and sets the IBNIRQ bit for the endpoint.

Set **IE=1** to enable the interrupt, and **IE=0** to disable it.

An IRQ bit is set to **1** to indicate an interrupt request. The interrupt source is available in the interrupt vector register IVEC2. **The firmware clears an IRQ bit by writing a 1 to it.**



Do **not** clear an IRQ bit by reading an IRQ Register, ORing its contents with a bit mask, and writing back the IRQ Register. This will clear ALL pending interrupts. Instead, simply write the bit mask value (with a “1” in the bit position of the IRQ you want to clear) directly to the IRQ Register.

### 15.7.3 Endpoint Ping-NAK/IBN Interrupt Enable/Request

#### NAKIE Endpoint Ping-NAK/IBN Interrupt Enable (INT2) E65A

b7	b6	b5	b4	b3	b2	b1	b0
<b>EP8</b>	<b>EP6</b>	<b>EP4</b>	<b>EP2</b>	<b>EP1</b>	<b>EP0</b>	<b>0</b>	<b>IBN</b>
R/W	R/W	R/W	R/W	R/W	R/W	R/W	R/W
0	0	0	0	0	0	0	0

Figure 15-39. Endpoint Ping-NAK/IBN Interrupt Enable

#### NAKIRQ Endpoint Ping-NAK/IBN Interrupt Request (INT2) E65B

b7	b6	b5	b4	b3	b2	b1	b0
<b>EP8</b>	<b>EP6</b>	<b>EP4</b>	<b>EP2</b>	<b>EP1</b>	<b>EP0</b>	<b>0</b>	<b>IBN</b>
R/W	R/W	R/W	R/W	R/W	R/W	R/W	R/W
x	x	x	x	x	x	x	x

Figure 15-40. Endpoint Ping-NAK/IBN Interrupt Request

#### Bit 7-2 EP[8,6,4,2,1,0] Ping-NAK INT Enable/Request

These registers are active only during high speed (480 Mbits/sec) operation.

USB 2.0 improves the USB 1.1 bus bandwidth utilization by implementing a PING-NAK mechanism for OUT transfers. When the host wishes to send OUT data to an endpoint, it first sends a PING token to see if the endpoint is ready, i.e. it has an empty buffer. If a buffer is not available, the SIE returns a NAK handshake. PING-NAK transactions continue to occur until an OUT buffer is available, at which time the FX2 SIE answers a PING with an ACK handshake. Then the host sends the OUT data to the endpoint.

The OUT Ping NAK interrupt indicates that the host is trying to send OUT data, but the SIE responded with a NAK because no endpoint buffer memory is available. The firmware may wish to use this interrupt to free up an OUT endpoint buffer.

**Bit 0**
**IBN**
*IBN INT Enable/Request*

This bit is automatically set when any of the IN bulk endpoints responds to an IN token with a NAK. This interrupt occurs when the host sends an IN token to a bulk IN endpoint which has not yet been armed. Individual enables and requests (per endpoint) are controlled by the IBNIE and IBNIRQ Registers. Write a “1” to this bit to clear the interrupt request.

The IBN INT only fires on a 0-to-1 transition of an “OR” condition of all IBN sources that are enabled.

**The firmware clears an IRQ bit by writing a 1 to it.**



*Do not clear an IRQ bit by reading an IRQ Register, ORing its contents with a bit mask, and writing back the IRQ Register. This will clear ALL pending interrupts. Instead, simply write the bit mask value (with a “1” in the bit position of the IRQ you want to clear) directly to the IRQ Register.*

### 15.7.4 USB Interrupt Enable/Request

USBIE								USB Interrupt Enables (INT2)								E65C	
b7		b6		b5		b4		b3		b2		b1		b0			
<b>0</b>		<b>EP0ACK</b>		<b>HSGRANT</b>		<b>URES</b>		<b>SUSP</b>		<b>SUTOK</b>		<b>SOF</b>		<b>SUDAV</b>			
R/W		R/W		R/W		R/W		R/W		R/W		R/W		R/W			
0		0		0		0		0		0		0		0			

Figure 15-41. USB Interrupt Enables

USBIRQ								USB Interrupt Requests (INT2)								E65D	
b7		b6		b5		b4		b3		b2		b1		b0			
<b>0</b>		<b>EP0ACK</b>		<b>HSGRANT</b>		<b>URES</b>		<b>SUSP</b>		<b>SUTOK</b>		<b>SOF</b>		<b>SUDAV</b>			
R/W		R/W		R/W		R/W		R/W		R/W		R/W		R/W			
0		x		x		x		x		x		x		x			

Figure 15-42. USB Interrupt Requests

**Bit 6**
**EP0ACK**
*EndPoint 0 Acknowledge*

Status stage completed

**Bit 5**                      **HSGRANT**                                      *Grant High Speed Access*

The FX2 SIE sets this bit when it has been granted high speed (480 Mbits/sec) access to USB.

**Bit 4**                      **URES**    *USB Reset Interrupt Request*

The USB signals a bus reset by driving both D+ and D- low for at least 10 milliseconds. When the USB core detects the onset of USB bus reset, it activates the URES Interrupt Request. The USB core sets this bit to “1” when it detects a USB bus reset. Write a “1” to this bit to clear the interrupt request.

**Bit 3**                      **SUSP**    *Suspend Interrupt Request*

If the EZ-USB FX2 detects 3 ms of no bus activity, it activates the SUSP (Suspend) Interrupt Request. The USB core sets this bit to “1” when it detects USB SUSPEND signaling (no bus activity for 3 ms). Write a “1” to this bit to clear the interrupt request.

**Bit 2**                      **SUTOK**    *Setup Token*

The USB core sets this bit to “1” when it receives a SETUP token. Write a “1” to this bit to clear the interrupt request.

**Bit 1**                      **SOF**    *Start of Frame*

The USB core sets this bit to “1” when it receives a SOF packet. Write a “1” to this bit to clear the interrupt request.

**Bit 0**                      **SUDAV**    *SETUP Data Available Interrupt Request*

The USB core sets this bit to “1” when it has transferred the eight data bytes from an endpoint zero SETUP packet into internal registers (at SETUPDAT). Write a “1” to this bit to clear the interrupt request.



*Do **not** clear an IRQ bit by reading an IRQ Register, ORing its contents with a bit mask, and writing back the IRQ Register. This will clear ALL pending interrupts. Instead, simply write the bit mask value (with a “1” in the bit position of the IRQ you want to clear) directly to the IRQ Register.*



## 15.7.5 Endpoint Interrupt Enable/Request

### EPIE Endpoint Interrupt Enables (INT2) E65E

b7	b6	b5	b4	b3	b2	b1	b0
<b>EP8</b>	<b>EP6</b>	<b>EP4</b>	<b>EP2</b>	<b>EP1OUT</b>	<b>EP1IN</b>	<b>EP0OUT</b>	<b>EP0IN</b>
R/W	R/W	R/W	R/W	R/W	R/W	R/W	R/W
0	0	0	0	0	0	0	0

Figure 15-43. Endpoint Interrupt Enables

### EPIRQ Endpoint Interrupt Requests (INT2) E65F

b7	b6	b5	b4	b3	b2	b1	b0
<b>EP8</b>	<b>EP6</b>	<b>EP4</b>	<b>EP2</b>	<b>EP1OUT</b>	<b>EP1IN</b>	<b>EP0OUT</b>	<b>EP0IN</b>
R/W	R/W	R/W	R/W	R/W	R/W	R/W	R/W
x	x	x	x	x	x	x	x

Figure 15-44. Endpoint Interrupt Requests

These Endpoint interrupt enable/request registers indicate the pending interrupts for each bulk endpoint. For IN endpoints, the interrupt asserts when the host takes a packet from the endpoint; for OUT endpoints, the interrupt asserts when the host supplies a packet to the endpoint.

The IRQ bits function independently of the Interrupt Enable (IE) bits, so interrupt requests are held whether or not the interrupts are enabled.



*Do **not** clear an IRQ bit by reading an IRQ Register, ORing its contents with a bit mask, and writing back the IRQ Register. This will clear ALL pending interrupts. Instead, simply write the bit mask value (with a “1” in the bit position of the IRQ you want to clear) directly to the IRQ Register.*

## 15.7.6 GPIF Interrupt Enable/Request

**GPIFIE**                      **GPIF Interrupt Enable (INT4)**                      **E660**  
*see Section 15.14*

b7	b6	b5	b4	b3	b2	b1	b0
0	0	0	0	0	0	<b>GPIFWF</b>	<b>GPIFDONE</b>
R/W	R/W	R/W	R/W	R/W	R/W	R/W	R/W
0	0	0	0	0	0	0	0

Figure 15-45. GPIF Interrupt Enable

**GPIFIRQ**                      **GPIF Interrupt Request (INT4)**                      **E661**  
*see Section 15.14*

b7	b6	b5	b4	b3	b2	b1	b0
0	0	0	0	0	0	<b>GPIFWF</b>	<b>GPIFDONE</b>
R/W	R/W	R/W	R/W	R/W	R/W	R/W	R/W
0	0	0	0	0	0	x	x

Figure 15-46. GPIF Interrupt Request

**Bit 1**                      **GPIFWF**                      *FIFO Read/Write Waveform*

GPIF-to-firmware “hook” in Waveform, when waveform descriptor is programmed to assert the GPIFWF interrupt.

**Bit 0**                      **GPIFDONE**                      *GPIF Idle State*

0 = Transaction in progress.

1 = Transaction Done (GPIF is idle, hence GPIF is ready for next Transaction). Fires IRQ4 if enabled.

The firmware clears an interrupt request bit by writing a “1” to it.



*Do not clear an IRQ bit by reading an IRQ Register, ORing its contents with a bit mask, and writing back the IRQ Register. This will clear ALL pending interrupts. Instead, simply write the bit mask value (with a “1” in the bit position of the IRQ you want to clear) directly to the IRQ Register.*

### 15.7.7 USB Error Interrupt Enable/Request

#### USBERRIE USB Error Interrupt Enables (INT2) E662

b7	b6	b5	b4	b3	b2	b1	b0
<b>ISOEP8</b>	<b>ISOEP6</b>	<b>ISOEP4</b>	<b>ISOEP2</b>	<b>0</b>	<b>0</b>	<b>0</b>	<b>ERRLIMIT</b>
R/W	R/W	R/W	R/W	R/W	R/W	R/W	R/W
0	0	0	0	0	0	0	0

Figure 15-47. USB Error Interrupt Enables

#### USBERRIRQ USB Error Interrupt Request (INT2) E663

b7	b6	b5	b4	b3	b2	b1	b0
<b>ISOEP8</b>	<b>ISOEP6</b>	<b>ISOEP4</b>	<b>ISOEP2</b>	<b>0</b>	<b>0</b>	<b>0</b>	<b>ERRLIMIT</b>
R/W	R/W	R/W	R/W	R/W	R/W	R/W	R/W
x	x	x	x	0	0	0	x

Figure 15-48. USB Error Interrupt Request

#### Bit 7-4 ISOEP[8,6,4,2] ISO Error Packet

The ISO EP Flag is set when:

- ISO OUT data PIDs arrive out of sequence (applies to high speed only).
- An ISO OUT packet was dropped because no buffer space was available for an OUT packet (in either full- or high-speed modes).

#### Bit 0 ERRLIMIT Error Limit

ERRLIMIT counts USB bus errors—CRC, bit stuff, etc., and triggers the interrupt when the programmed limit (0-15) is reached.

The firmware clears an interrupt request bit by writing a “1” to it. (See the following Note).



*Do not clear an IRQ bit by reading an IRQ Register, ORing its contents with a bit mask, and writing back the IRQ Register. This will clear ALL pending interrupts. Instead, simply write the bit mask value (with a “1” in the bit position of the IRQ you want to clear) directly to the IRQ Register.*

### 15.7.8 USB Error Counter Limit

#### ERRCNTLIM USB Error Counter and Limit E664

b7	b6	b5	b4	b3	b2	b1	b0
<b>EC3</b>	<b>EC2</b>	<b>EC1</b>	<b>EC0</b>	<b>LIMIT3</b>	<b>LIMIT2</b>	<b>LIMIT1</b>	<b>LIMIT0</b>
R	R	R	R	R/W	R/W	R/W	R/W
x	x	x	x	0	1	0	0

Figure 15-49. USB Error Counter and Limit

**Bit 7-4**                      **EC3:0**    *USB Error Count*

Error count has a maximum value of 15.

**Bit 3-0**                      **LIMIT3:0**    *Error Count Limit*

USB bus error count and limit. The firmware can enable the interrupt to cause an interrupt when the limit is reached. The default limit count is 4.

### 15.7.9 Clear Error Count

#### CLRERRCNT Clear Error Count EC3:0 E665

b7	b6	b5	b4	b3	b2	b1	b0
<b>x</b>	<b>x</b>	<b>x</b>	<b>x</b>	<b>x</b>	<b>x</b>	<b>x</b>	<b>x</b>
W	W	W	W	W	W	W	W
x	x	x	x	x	x	x	x

Figure 15-50. Clear Error Count EC3:0

Write 0xFF to this register to clear the EC (Error Count) bits in the ERRCNTLIM Register.

### 15.7.10 INT 2 (USB) Autovector

INT2IVEC		INTERRUPT 2 (USB) Autovector					E666	
b7	b6	b5	b4	b3	b2	b1	b0	
<b>0</b>	<b>I2V4</b>	<b>I2V3</b>	<b>I2V2</b>	<b>I2V1</b>	<b>I2V0</b>	<b>0</b>	<b>0</b>	
R	R	R	R	R	R	R	R	
0	0	0	0	0	0	0	0	

Figure 15-51. INT 2 (USB) Autovector

**Bit 6-2**                      **I2V4:0**    *INT 2 Autovector*

To save the code and processing time required to sort out which USB interrupt occurred, the USB core provides a second level of interrupt vectoring, called Autovectoring. When the CPU takes a USB interrupt, it pushes the program counter onto its stack, and then executes a jump to address 43, where it expects to find a jump instruction to the INT2 service routine.

I2V indicates the source of an interrupt from the USB Core. When the USB core generates an INT2 (USB) Interrupt Request, it updates INT2IVEC to indicate the source of the interrupt. The interrupt sources are encoded on I2V4:0.

### 15.7.11 INT 4 (slave FIFOs & GPIF) Autovector

INT4IVEC		Interrupt 4 (slave FIFOs & GPIF) Autovector					E667	
b7	b6	b5	b4	b3	b2	b1	b0	
<b>1</b>	<b>0</b>	<b>I4V3</b>	<b>I4V2</b>	<b>I4V1</b>	<b>I4V0</b>	<b>0</b>	<b>0</b>	
R	R	R	R	R	R	R	R	
1	0	0	0	0	0	0	0	

Figure 15-52. INT 4 (slave FIFOs & GPIF) Autovector

**Bit 5-2**                      **I4V3:0**    *INT 4 Autovector*

To save the code and processing time required to sort out which FIFO interrupt occurred, the USB core provides a second level of interrupt vectoring, called Autovectoring. When the CPU takes a USB interrupt, it pushes the program counter onto its stack, and then executes a jump to address 53, where it expects to find a jump instruction to the INT4 service routine.

I4V indicates the source of an interrupt from the USB Core. When the USB core generates an INT4 (FIFO/GPIF) Interrupt Request, it updates INT4IVEC to indicate the source of the interrupt. The interrupt sources are encoded on I2V3:0.

### 15.7.12 INT 2 and INT 4 Setup

INTSETUP				INT 2 & INT 4 Setup				E668
b7	b6	b5	b4	b3	b2	b1	b0	
0	0	0	0	AV2EN	0	INT4SRC	AV4EN	
R/W	R/W	R/W	R/W	R/W	R/W	R/W	R/W	
0	0	0	0	0	0	0	0	

Figure 15-53. INT 2 and INT 4 Setup

**Bit 3**                      **AV2EN**                                      *INT2 Autovector Enable*

To streamline the code that deals with the USB interrupts, this bit enables autovectoring on INT2.

**Bit 1**                      **INT4SRC**    *INT 4 Source*

If 0, INT4 is supplied by the pin. If **INT4SRC** = 1:INT4 supplied internally from FIFO/GPIF sources.

**Bit 0**                      **AV4EN**    *INT4 Autovector Enable*

To streamline the 8051 code that deals with the FIFO interrupts, this bit enables autovectoring on INT4.

## 15.8 Input/Output Registers

### 15.8.1 I/O PORTA Alternate Configuration

PORTACFG		I/O PORTA Alternate Configuration						E670
b7	b6	b5	b4	b3	b2	b1	b0	
<b>FLAGD</b>	<b>SLCS</b>	<b>0</b>	<b>0</b>	<b>0</b>	<b>0</b>	<b>INT1</b>	<b>INT0</b>	
R/W	R/W	R/W	R/W	R/W	R/W	R/W	R/W	
0	0	0	0	0	0	0	0	

Figure 15-54. I/O PORTA Alternate Configuration



Note: Bit 3 is the WU2EN bit in the Wakeup register.

The PORTxCFG register selects alternate functions for the PORTx pins.

**Bit 7**                      **FLAGD**                      *FlagD Alternate Configuration*

If IFCFG1:0=11, setting this bit to '1' configures the PA7 pin as FLAGD, a programmable FIFO flag.

**Bit 6**                      **SLCS**                       *$\overline{SLCS}$  Alternate Configuration*

If IFCFG1:0=11, setting this bit to '1' configures the PA7 pin as  $\overline{SLCS}$ , the slave-FIFO chip-select.

**Bit 1-0**                      **INT1:0**                      *Interrupts Enabled for Alternate Configuration*

Setting these bits to '1' configures these PORTA pins as the INT1 or INT0 pins.



Note: Bits PORTACFG.7 and PORTACFG.6 both affect pin PA7. If both bits are set, FLAGD takes precedence.

### 15.8.2 I/O PORTC Alternate Configuration

PORTCCFG							I/O PORTC Alternate Configuration	E671
b7	b6	b5	b4	b3	b2	b1	b0	
<b>GPIFA7</b>	<b>GPIFA6</b>	<b>GPIFA5</b>	<b>GPIFA4</b>	<b>GPIFA3</b>	<b>GPIFA2</b>	<b>GPIFA1</b>	<b>GPIFA0</b>	
R/W	R/W	R/W	R/W	R/W	R/W	R/W	R/W	
0	0	0	0	0	0	0	0	

Figure 15-55. I/O PORTC Alternate Configuration

**Bit 7-0**                      **GPIFA7:0**                                      *Enable GPIF Address Pins*

Set these pins to “1” to configure this port to output the lower address of enabled GPIF address pins. Additional bit set in PORTECFG, bit 7.

Set these pins to “0” to configure this as Port C.

### 15.8.3 I/O PORTE Alternate Configuration

PORTECFG						I/O PORTE Alternate Configuration		E672
b7	b6	b5	b4	b3	b2	b1	b0	
<b>GPIFA8</b>	<b>T2EX</b>	<b>INT6</b>	<b>RXD1OUT</b>	<b>RXD0OUT</b>	<b>T2OUT</b>	<b>T1OUT</b>	<b>T0OUT</b>	
R/W	R/W	R/W	R/W	R/W	R/W	R/W	R/W	
0	0	0	0	0	0	0	0	

Figure 15-56. I/O PORTE Alternate Configuration

**Bit 7**                                      **GPIFA8**    *Enable GPIF Address Pin*

GPIF address bit 8 pin. Set these pin to “1” to configure this port to output the high address of enabled GPIF address pins.

Set these pin to “0” to configure this as Port E.

**Bit 6**                                      **T2EX**    *Timer 2 Counter*

Timer/Counter 2 Capture/Reload Input.



**Bit 5**                      **INT6**    *INT6 Interrupt Request*  
 Setting this bit to '1' configures this Port E pin as INT6.

**Bit 4**                      **RXD1OUT**    *Mode 0: UART1 Synchronous Data Output*  
 Mode 0: UART1 Synchronous Data Output.

**Bit 3**                      **RXD0OUT**    *Mode 0: UART0 Synchronous Data Output*  
 Mode 0: UART0 Synchronous Data Output.

**Bit 2-0**                      **T2OUT, T1OUT, T0OUT**    *Serial Data*  
 Serial mode 0 provides synchronous, half-duplex serial communication. For Serial Port 0, serial data output occurs on the RXD0OUT pin, serial data is received on the RXD0 pin, and the TXD0 pin provides the shift clock for both transmit and receive. Mode 0: Clock Output  
 Modes 1-3: Serial Port 0 Data Output.

### 15.8.4 I<sup>2</sup>C Compatible Bus Control and Status

I2CS		I <sup>2</sup> C-Compatible Bus Control and Status				E678	
b7	b6	b5	b4	b3	b2	b1	b0
<b>START</b>	<b>STOP</b>	<b>LASTRD</b>	<b>ID1</b>	<b>ID0</b>	<b>BERR</b>	<b>ACK</b>	<b>DONE</b>
R/W	R/W	R/W	R	R	R	R	R
0	0	0	x	x	0	0	0

Figure 15-57. I<sup>2</sup>C-Compatible Bus Control and Status

**Bit 7**                      **START**    *Signal START Condition*  
 Set the START bit to “1” to prepare a bus transfer. If START=1, the next write to I2DAT will generate the start condition followed by the serialized byte of data in I2DAT. The firmware loads byte data into I2DAT after setting the START bit. The bus controller clears the START bit during the ACK interval.

**Bit 6**                      **STOP**    *Signal STOP Condition*  
 Set STOP=1 to terminate a bus transfer. The bus controller clears the STOP bit after completing the STOP condition. If the firmware sets the STOP bit during a byte transfer, the STOP condition will be generated immediately following the ACK phase of the byte transfer. If no byte transfer is occurring when the STOP bit is set, the STOP condition will be carried out immediately on the bus. Data should not be written to I2CS or I2DAT until the STOP bit returns low.

**Bit 5**                      **LASTRD**                      *Last Data Read*

To read data over the I<sup>2</sup>C compatible bus, a bus master floats the SDA line and issues clock pulses on the SCL line. After every eight bits, the master drives SDA low for one clock to indicate ACK. To signal the last byte of the read transfer, the master floats SDA at ACK time to instruct the slave to stop sending. This is controlled by setting LastRD=1 before reading the last byte of a read transfer. The bus controller clears the LastRD bit at the end of the transfer (at ACK time).

**Bit 4-3**                      **ID1:0**                      *Boot EEPROM ID*

These bits are set by the boot loader to indicate whether an 8-bit address or 16-bit address EEPROM at slave address 000 or 001 was detected at power-on. Normally, they are used for debug purposes only.

**Bit 2**                      **BERR**                      *Bus Error*

This bit indicates a bus error. BERR=1 indicates that there was bus contention, which results when an outside device drives the bus low when it should not, or when another bus master wins arbitration, taking control of the bus. BERR is cleared when the IDATA register is read or written.

**Bit 1**                      **ACK**                      *Acknowledge Bit*

Every ninth SCL or a write transfer the slave indicates reception of the byte by asserting ACK. The bus controller floats SDA during this time, samples the SDA line, and updates the ACK bit with the complement of the detected value. ACK=1 indicates acknowledge, and ACK=0 indicates not-acknowledge. The USB core updates the ACK bit at the same time it sets DONE=1. The ACK bit should be ignored for read transfers on the bus.

**Bit 0**                      **DONE**                      *Transfer DONE*

The bus controller sets this bit whenever it completes a byte transfer, right after the ACK stage. The controller also generates an Interrupt Request (INT3) when it sets the DONE bit. The bus controller automatically clears the DONE bit and the Interrupt Request bit whenever the IDAT register is read or written.



**Bit 0****400KHZ***High-speed I<sup>2</sup>C Compatible Bus*

For I<sup>2</sup>C-compatible peripherals that support it, the I<sup>2</sup>C-compatible bus can run at 400 KHz. For compatibility, the bus powers-up at the 100-KHz frequency. If 400KHZ=0, the I<sup>2</sup>C-compatible bus operates at approximately 100 KHz. If 400KHZ=1, the I<sup>2</sup>C-compatible bus operates at approximately 400 KHz. This bit is copied to the I<sup>2</sup>CCTL register bit 0, which is read-write to the firmware. Thus the I<sup>2</sup>C-compatible bus speed is initially set by the EEPROM bit, and may be changed subsequently by firmware.

**15.8.7 AUTOPOINTERS 1 and 2 MOVX access**

<b>XAUTODAT1</b>	<b>AUTOPTR1 MOVX access</b>	<b>E67B</b>
<b>XAUTODAT2</b>	<b>AUTOPTR2 MOVX access</b>	<b>E67C</b>

b7	b6	b5	b4	b3	b2	b1	b0
<b>D7</b>	<b>D6</b>	<b>D5</b>	<b>D4</b>	<b>D3</b>	<b>D2</b>	<b>D1</b>	<b>D0</b>
R/W	R/W	R/W	R/W	R/W	R/W	R/W	R/W
x	x	x	x	x	x	x	x

Figure 15-60. AUTOPTR1 & AUTOPTR2 MOVX access (when EXTACC=1)

**Bit 7-0****Data***AUTODATAx*

Data read or written to the xAUTODATn register accesses the memory addressed by the AUTOPTRHn/Ln registers, and optionally increments the address after the read or write.

## 15.9 UDMA CRC Registers

For complete Flowstate / UDMA information, please contact the Cypress Semiconductor Applications Department.

### UDMACRCH E67D see Section 15.14

b7	b6	b5	b4	b3	b2	b1	b0
<b>CRC[15:8]</b>							
RW	RW	RW	RW	RW	RW	RW	RW
0	1	0	0	1	0	1	0

### UDMACRCL E67E see Section 15.14

b7	b6	b5	b4	b3	b2	b1	b0
<b>CRC[7:0]</b>							
RW	RW	RW	RW	RW	RW	RW	RW
1	0	1	1	1	0	1	0

These two registers are strictly for debug purposes. The CRC represented by these registers is calculated based on the rules defined in the ATAPI specification for UDMA transfers. It is calculated automatically by the GPIF as data is transferred on FD[15:0].

These registers will return the live calculation of the CRC at any point in the transfer, but will be reset to the seed value of 0x4ABA upon the GPIF entering the IDLE state. These registers are writable; thus the currently calculated CRC including the seed value can be overwritten at any time.

**UDMACRCQUALIFIER****E67F**

b7	b6	b5	b4	b3	b2	b1	b0
<b>QENABLE</b>	<b>0</b>	<b>0</b>	<b>0</b>	<b>QSTATE</b>	<b>Q SIGNAL[2:0]</b>		
RW	R	R	R	RW	RW	RW	RW
0	0	0	0	0	0	0	0

**This register only applies to UDMA IN transactions that are host terminated. Otherwise, this register can be completely ignored.**

This register covers a very specific and potentially nonexistent (from a typical system implementation standpoint\*) UDMA CRC situation. However rare the situation may be, it is still allowed by the ATAPI specification and thus must be considered and solved by this register.

The ATAPI specification says that if the host (in this case the GPIF) terminates a UDMA IN transaction, that the device (e.g., the disk drive) is allowed to send up to 3 more words after the host deactivates the HDMARDY signal. These “dribble” words may not be of interest to the host and thus may be discarded. However, CRC must still be calculated on them since the host and the device must compare and match the CRC at the end of the transaction to consider the transfer error-free.

The GPIF normally only calculates CRC on words that are written into the FIFO (and not discarded). This poses a problem since in this case some words will be discarded but still must be included in the CRC calculation. This register gives a way to have the GPIF calculate CRC on the extra discarded words as well.

The user would program this register in the following way. The QENABLE bit would be set to 1. The Q SIGNAL[2:0] field would be programmed to select the CTL pin that coincides with the UDMA STOP signal. The QSTATE bit would be programmed to be 0. This would instruct the GPIF to calculate CRC on any DSTROBE edges from the device when STOP=0, which solves the problem.

**Bit 7                    QENABLE**

This bit enables the CRC qualifier feature, and thus the other bits in this register.

**Bit 3                    QSTATE**

This bit says what state the CRC qualifier signal (selected by Q SIGNAL[2:0] below) must be in to allow CRC to be calculated on words being written into the GPIF.

**Bits 2-0                Q SIGNAL[2:0]**

These bits select which of the CTL[5:0] pins is the CRC qualifier signal.

\* - A typical UDMA system will have the device, instead of the host, terminate UDMA IN transfers thus completely avoiding this situation.

## 15.10 USB Control

### 15.10.1 USB Control and Status

USBCS		USB Control and Status						E680
b7	b6	b5	b4	b3	b2	b1	b0	
<b>HSM</b>	<b>0</b>	<b>0</b>	<b>0</b>	<b>DISCON</b>	<b>NOSYNOSOF</b>	<b>RENUM</b>	<b>SIGRSUME</b>	
R	R	R	R	R/W	R/W	R/W	R/W	
x	0	0	0	0	0	0	0	

Figure 15-61. USB Control and Status

**Bit 7**                      **HSM**    *High Speed Mode*

If HSM=1, the SIE is operating in High Speed Mode, 480 bits/sec. 0-1 transition of this bit causes a HSGRANT interrupt request.

**Bit 3**                      **DISCON**    *Signal a Disconnect on the  $\overline{DISCON}$  Pin*

DISCON is one of the EZ-USB FX2 control bits in the USBCS (USB Control and Status) Register that control the ReNumeration process. Setting this bit to “1” will disconnect from the USB bus by removing the internal 1.5 K pull-up resistor from the D+. A boot EEPROM may be used to default this bit to 1 at startup time. This bit will also reset several registers. See *Chapter 7 “Resets”* for details.

**Bit 2**                      **NOSYNOSOF**    *Disable Synthesizing Missing SOFs*

If set to 1, disable synthesizing missing SOFs.

**Bit 1**                      **RENUM**    *Renumerate*

This bit controls whether USB device requests are handled by firmware or automatically by the FX2. When RENUM=0, the USB core handles all device requests. When RENUM=1, the firmware handles all device requests except Set\_Address. Set RENUM=1 during a bus disconnect to transfer USB control to the firmware. The FX2 automatically sets RENUM=1 under two conditions:

1. Completion of a “C2” boot load
2. When external memory is used (EA=1) and no boot EEPROM is used.

**Bit 0**                      **SIGRSUME**                      *Signal Remote Device Resume*

Set SIGRSUME=1 to drive the “K” state onto the USB bus. This should be done only by a device that is capable of remote wakeup, and then only during the SUSPEND state. To signal RESUME, set SIGRSUME=1, waits 10-15 ms, then sets SIGRSUME=0.

### 15.10.2 Enter Suspend State

**SUSPEND**                      **Put Chip into SUSPEND State**                      **E681**

b7	b6	b5	b4	b3	b2	b1	b0
x	x	x	x	x	x	x	x
W	W	W	W	W	W	W	W
x	x	x	x	x	x	x	x

Figure 15-62. Enter Suspend State

**Bit 7-0**                      **Suspend**                      *Enable Suspend  
Regardless of Bus State*

Write 0xFF to prepare the chip for standby without having to wait for a Bus Suspend.

### 15.10.3 Wakeup Control & Status

**WAKEUPCS**                      **Wakeup Control & Status**                      **E682**

b7	b6	b5	b4	b3	b2	b1	b0
<b>WU2</b>	<b>WU</b>	<b>WU2POL</b>	<b>WUPOL</b>	<b>0</b>	<b>DPEN</b>	<b>WU2EN</b>	<b>WUEN</b>
R/W	R/W	R/W	R/W	R	R/W	R/W	R/W
x	x	0	0	0	1	0	1

Figure 15-63. Wakeup Control & Status

FX2 has two pins that can be activated by external logic to take FX2 out of standby. These pins are called WAKEUP and WU2.

**Bit 7**                      **WU2**                      *Wakeup Initiated from WU2 Pin*

The FX2 sets this status bit to 1 when wakeup was initiated by the WU2 pin. Write a 1 to this bit to clear it.



- Bit 6**                      **WU**                                      *Wakeup Initiated from WU Pin*  
 The FX2 sets this bit to 1 when wakeup was initiated by the WU pin. Write a 1 to this bit to clear it.
- Bit 5**                      **WU2POL**    *Polarity of WU2 Pin*  
 Polarity of the WU2 input pin. 0 = active low, 1 = active high.
- Bit 4**                      **WUPOL**    *Polarity of WU Pin*  
 Polarity of the WU input pin. 0 = active low, 1 = active high.
- Bit 2**                      **DPEN**    *Enable/Disable DPLUS Wakeup*  
 Activity on the USB DPLUS signal normally initiates a USB wakeup sequence.  
  
 0=Disable  
 1=Enable
- Bit 1**                      **WU2EN**    *Enable WU2 Wakeup*  
 WU2EN =1: enable wakeup from WU2 pin.
- Bit 0**                      **WUEN**    *Enable WU Wakeup*  
 WUEN=1: enable wakeup from the WAKEUP pin.

---

#### 15.10.4 Data Toggle Control

TOGCTL		Data Toggle Control						E683
b7	b6	b5	b4	b3	b2	b1	b0	
<b>Q</b>	<b>S</b>	<b>R</b>	<b>IO</b>	<b>EP3</b>	<b>EP2</b>	<b>EP1</b>	<b>EP0</b>	
R	R/W	R/W	R/W	R/W	R/W	R/W	R/W	
x	x	x	x	x	x	x	x	

Figure 15-64. Data Toggle Control

- Bit 7**                      **Q**    *Data Toggle Value*  
 Q=0 indicates DATA0 and Q=1 indicates DATA1, for the endpoint selected by the I/O and EP3:0 bits. Write the endpoint select bits (IO and EP3:0), before reading this value.

**Bit 6**                      **S**                                      *Set Data Toggle to DATA1*

After selecting the desired endpoint by writing the endpoint select bits (IO and EP3:0), set S=1 to set the data toggle to DATA1. The endpoint selection bits should not be changed while this bit is written.

**Bit 5**                      **R**                                      *Set Data Toggle to DATA0*

Set R=1 to set the data toggle to DATA0. The endpoint selection bits should not be changed while this bit is written.

**Bit 4**                      **IO**                                      *Select IN or OUT Endpoint*

Set this bit to select an endpoint direction prior to setting its R or S bit. IO=0 selects an OUT endpoint, IO=1 selects an IN endpoint.

**Bit 3-0**                      **EP3:0**                                      *Select Endpoint*

Set these bits to select an endpoint prior to setting its R or S bit. Valid values are 0, 1, 2, 4, 6, and 8.

---

**15.10.5 USB Frame Count High****USBFRAMEH                      USB Frame Count HIGH                      E684**

b7	b6	b5	b4	b3	b2	b1	b0
<b>0</b>	<b>0</b>	<b>0</b>	<b>0</b>	<b>0</b>	<b>FC10</b>	<b>FC9</b>	<b>FC8</b>
R	R	R	R	R	R	R	R
0	0	0	0	0	x	x	x

*Figure 15-65. USB Frame Count HIGH*

**Bit 2-0**                      **FC10:8**                                      *High Bits for USB Frame Count*

Every millisecond the host sends a SOF token indicating "Start Of Frame," along with an 11-bit incrementing frame count. The EZ-USB FX2 copies the frame count into these registers at every SOF. One use of the frame count is to respond to the USB SYNC\_FRAME Request. If the USB core detects a missing or garbled SOF, it generates an internal SOF and increments USBFRAMEH-USBFRAMEH.

### 15.10.6 USB Frame Count Low

USBFRAMEL							USB Frame Count LOW	E685
b7	b6	b5	b4	b3	b2	b1	b0	
<b>FC7</b>	<b>FC6</b>	<b>FC5</b>	<b>FC4</b>	<b>FC3</b>	<b>FC2</b>	<b>FC1</b>	<b>FC0</b>	
R	R	R	R	R	R	R	R	
x	x	x	x	x	x	x	x	

Figure 15-66. USB Frame Count Low

**Bit 7-0**                      **FC7:0**                                      *Low Byte for USB Frame Count*

Every millisecond the host sends a SOF token indicating “Start Of Frame,” along with an 11-bit incrementing frame count. The EZ-USB FX2 copies the frame count into these registers at every SOF. One use of the frame count is to respond to the USB SYNC\_FRAME Request. If the USB core detects a missing or garbled SOF, it generates an internal SOF and increments USBFRAMEH-USBFRAMEH.

### 15.10.7 USB Microframe Count

MICROFRAME					USB Microframe Count, 0-7			E686
b7	b6	b5	b4	b3	b2	b1	b0	
<b>0</b>	<b>0</b>	<b>0</b>	<b>0</b>	<b>0</b>	<b>MF2</b>	<b>MF1</b>	<b>MF0</b>	
R	R	R	R	R	R	R	R	
0	0	0	0	0	x	x	x	

Figure 15-67. USB Microframe Count

**Bit 2-0**                      **MF2:0**                                      *Last Occurring Microframe*

MICROFRAME contains a count 0-7 which indicates which of the 8 125-microsecond microframes last occurred. This register is active only when FX2 is operating at high speed (480 Mbits/sec).

## 15.10.8 USB Function Address

FNADDR							USB Function Address	E687
b7	b6	b5	b4	b3	b2	b1	b0	
<b>0</b>	<b>FA6</b>	<b>FA5</b>	<b>FA4</b>	<b>FA3</b>	<b>FA2</b>	<b>FA1</b>	<b>FA0</b>	
R	R	R	R	R	R	R	R	
0	x	x	x	x	x	x	x	

Figure 15-68. USB Function Address

**Bit 6-0**                      **FA6:0**                                      *USB Function Address*

During the USB enumeration process, the host sends a device a unique 7-bit address, which the USB core copies into this register. There is normally no reason for the CPU to know its USB device address because the USB Core automatically responds only to its assigned address.

## 15.11 Endpoints

### 15.11.1 Endpoint 0 (Byte Count High)

EP0BCH							Endpoint 0 Byte Count HIGH	E68A
b7	b6	b5	b4	b3	b2	b1	b0	
<b>(BC15)</b>	<b>(BC14)</b>	<b>(BC13)</b>	<b>(BC12)</b>	<b>(BC11)</b>	<b>(BC10)</b>	<b>(BC9)</b>	<b>(BC8)</b>	
R/W	R/W	R/W	R/W	R/W	R/W	R/W	R/W	
x	x	x	x	x	x	x	x	

Figure 15-69. Endpoint 0 (Byte Count High)

**Bit 7-0**                      **BC15:8**                                      *High Order Byte Count*

Even though the EP0 buffer is only 64 bytes, the EP0 byte count is expanded to 16 bits to allow using the SUDPTR with a custom length, instead of USB-dictated length (from Setup Data Packet and number of requested bytes). The byte count bits in parentheses apply only when SDPAUTO (SUDPTRCTL.0) = 0.

The SIE normally determines how many bytes to send over EP0 in response to a device request by taking the smaller of (a) the wLength field in the SETUP packet, and (b) the number of bytes available for transfer (byte count).

### 15.11.2 Endpoint 0 Control and Status (Byte Count Low)

EP0BCL							Endpoint 0 Byte Count Low	E68B
b7	b6	b5	b4	b3	b2	b1	b0	
<b>(BC7)</b>	<b>BC6</b>	<b>BC5</b>	<b>BC4</b>	<b>BC3</b>	<b>BC2</b>	<b>BC1</b>	<b>BC0</b>	
R/W	R/W	R/W	R/W	R/W	R/W	R/W	R/W	
x	x	x	x	x	x	x	x	

Figure 15-70. Endpoint 0 Control and Status (Byte Count Low)

**Bit 7-0**                      **BC7:0**    *Low Order Byte Count*

Even though the EP0 buffer is only 64 bytes, the EP0 byte count is expanded to 16 bits to allow using the SUDPTR with a custom length, instead of USB-dictated length (from Setup Data Packet and number of requested bytes). The byte count bits in parentheses apply only when SDPAUTO (SUDPTRCTL.0) = 0.

### 15.11.3 Endpoint 1 OUT and IN Byte Count

EP1OUTBC							Endpoint 1 OUT Byte Count	E68D
EP1INBC							Endpoint 1 IN Byte Count	E68F
b7	b6	b5	b4	b3	b2	b1	b0	
<b>0</b>	<b>BC6</b>	<b>BC5</b>	<b>BC4</b>	<b>BC3</b>	<b>BC2</b>	<b>BC1</b>	<b>BC0</b>	
R/W	R/W	R/W	R/W	R/W	R/W	R/W	R/W	
0	x	x	x	x	x	x	x	

Figure 15-71. Endpoint 1 OUT/IN Byte Count

**Bit 7-0**                      **BC6:0**    *Endpoint 1 IN/OUT Byte Count*

### 15.11.4 Endpoint 2 and 6 Byte Count High

<b>EP2BCH</b> <i>see Section 15.14</i>	<b>Endpoint 2 Byte Count HIGH</b>	<b>E690</b>
<b>EP6BCH</b> <i>see Section 15.14</i>	<b>Endpoint 6 Byte Count HIGH</b>	<b>E698</b>

b7	b6	b5	b4	b3	b2	b1	b0
<b>0</b>	<b>0</b>	<b>0</b>	<b>0</b>	<b>0</b>	<b>BC10</b>	<b>BC9</b>	<b>BC8</b>
R/W	R/W	R/W	R/W	R/W	R/W	R/W	R/W
0	0	0	0	0	x	x	x

Figure 15-72. Endpoint 2 and 6 Byte Count High

**Bit 1-0**                      **BC9:8**                      *Endpoint 2, 6 Byte Count High*

EP2 and EP6 can be either 512 or 1024 bytes. These are the high 2 bits of the byte-count.

### 15.11.5 Endpoint 4 and 8 Byte Count High

<b>EP4BCH</b> <i>see Section 15.14</i>	<b>Endpoint 4 Byte Count HIGH</b>	<b>E694</b>
<b>EP8BCH</b> <i>see Section 15.14</i>	<b>Endpoint 8 Byte Count HIGH</b>	<b>E69C</b>

b7	b6	b5	b4	b3	b2	b1	b0
<b>0</b>	<b>0</b>	<b>0</b>	<b>0</b>	<b>0</b>	<b>0</b>	<b>BC9</b>	<b>BC8</b>
R/W	R/W	R/W	R/W	R/W	R/W	R/W	R/W
0	0	0	0	0	0	x	x

Figure 15-73. Endpoint 4 and 5 Byte Count High

**Bit 0**                      **BC8**                      *Endpoint 4, 8 Byte Count High*

EP4 and EP8 can be 512 bytes only. This is the most significant bit of the byte-count.

### 15.11.6 Endpoint 2, 4, 6, 8 Byte Count Low

<b>EP2BCL</b> <i>see Section 15.14</i>	<b>Endpoint 2 Byte Count LOW</b>	<b>E691</b>
<b>EP4BCL</b> <i>see Section 15.14</i>	<b>Endpoint 4 Byte Count LOW</b>	<b>E695</b>
<b>EP6BCL</b> <i>see Section 15.14</i>	<b>Endpoint 6 Byte Count LOW</b>	<b>E699</b>
<b>EP8BCL</b> <i>see Section 15.14</i>	<b>Endpoint 8 Byte Count LOW</b>	<b>E69D</b>

b7	b6	b5	b4	b3	b2	b1	b0
<b>BC7/SKIP</b>	<b>BC6</b>	<b>BC5</b>	<b>BC4</b>	<b>BC3</b>	<b>BC2</b>	<b>BC1</b>	<b>BC0</b>
R/W	R/W	R/W	R/W	R/W	R/W	R/W	R/W
x	x	x	x	x	x	x	x

Figure 15-74. Endpoint 2, 4, 6, 8 Byte Count Low

**Bit 7**                      **BC7/SKIP**                      *Byte Count and Skip Packet*

For IN endpoints, b7=BC7 and BC[6:0] are valid.

For OUT endpoints, writing a byte count with '1' in the SKIP bit releases the buffer back to the SIE. Writing a the byte count with a '0' in this position releases the buffer to the FIFO.

**Bit 6-0**                      **BC6:0**                      *Byte Count*

Low byte count for Endpoints 2, 4, 6, and 8.

### 15.11.7 Endpoint 0 Control and Status

<b>EP0CS</b>	<b>Endpoint 0 Control and Status</b>	<b>E6A0</b>
--------------	--------------------------------------	-------------

b7	b6	b5	b4	b3	b2	b1	b0
<b>HSNAK</b>	<b>0</b>	<b>0</b>	<b>0</b>	<b>0</b>	<b>0</b>	<b>BUSY</b>	<b>STALL</b>
R/W	R/W	R/W	R/W	R/W	R/W	R	R/W
1	0	0	0	0	0	0	0

Figure 15-75. Endpoint 0 Control and Status

**Bit 7**                      **HSNAK**                                      *Hand Shake w/ NAK*

The STATUS stage consists of an empty data packet with the opposite direction of the data stage, or an IN if there was no data stage. This empty data packet gives the device a chance to ACK, NAK, or STALL the entire CONTROL transfer. Write a “1” to the NAK (handshake NAK) bit to clear it and instruct the USB core to ACK the STATUS stage. The HSNACK bit holds off completing the CONTROL transfer until the device has had time to respond to a request. Clear the HSNACK bit (by writing “1” to it) to instruct the USB core to ACK the status stage of the transfer.

**Bit 1**                      **BUSY**    *EP0 Buffer Busy*

BUSY is a read-only bit that is automatically cleared when a SETUP token arrives. The BUSY bit is set by writing a byte count to EP0BCL.

**Bit 0**                      **STALL**    *EP0 Stalled*

STALL is a read/write bit that is automatically cleared when a SETUP token arrives. The STALL bit is set by writing a “1” to the register bit.

While STALL=1, the USB core sends the STALL PID for any IN or OUT token. This can occur in either the data or handshake phase of the CONTROL transfer.



*To indicate an endpoint stall on endpoint zero, set both STALL and HSNACK bits. Setting the STALL bit alone causes endpoint zero to NAK forever because the host keeps the control transfer pending.*

**15.11.8 Endpoint 1 OUT/IN Control and Status**

<b>EP1OUTCS</b>	<b>Endpoint 1 OUT Control and Status</b>	<b>E6A1</b>
<b>EP1INCS</b>	<b>Endpoint 1 IN Control and Status</b>	<b>E6A2</b>

b7	b6	b5	b4	b3	b2	b1	b0
<b>0</b>	<b>0</b>	<b>0</b>	<b>0</b>	<b>0</b>	<b>0</b>	<b>BUSY</b>	<b>STALL</b>
R/W	R/W	R/W	R/W	R/W	R/W	R	R/W
0	0	0	0	0	0	0	0

*Figure 15-76. Endpoint 1 OUT/IN Control and Status*

**Bit 1**                      **BUSY**    *OUT/IN Endpoint Busy*

The BUSY bit indicates the status of the endpoint’s OUT Buffer EP1OUTBUF. The USB core sets BUSY=0 when the host data is available in the OUT buffer. The firmware sets BUSY=1 by loading the endpoint’s byte count register.



When  $BUSY=1$ , endpoint RAM data is invalid—the endpoint buffer has been emptied by the firmware and is waiting for new OUT data from the host, or it is the process of being loaded over the USB.  $BUSY=0$  when the USB OUT transfer is complete and endpoint RAM data in EP1OUTBUF is available for the firmware to read. USB OUT tokens for the endpoint are NAK'd while  $BUSY=1$  (the firmware is still reading data from the OUT endpoint).

A 1-to-0 transition of  $BUSY$  (indicating that the firmware can access the buffer) generates an interrupt request for the OUT endpoint. After the firmware reads the data from the OUT endpoint buffer, it loads the endpoint's byte count register with any value to re-arm the endpoint, which automatically sets  $BUSY=1$ . This enables the OUT transfer of data from the host in response to the next OUT token. The CPU should never read endpoint data while  $BUSY=1$ .

The  $BUSY$  bit, also indicates the status of the endpoint's IN Buffer EP1INBUF. The USB core sets  $BUSY=0$  when the endpoint's IN buffer is empty and ready for loading by the firmware. The firmware sets  $BUSY=1$  by loading the endpoint's byte count register.

When  $BUSY=1$ , the firmware should not write data to an IN endpoint buffer, because the endpoint FIFO could be in the act of transferring data to the host over the USB.  $BUSY=0$  when the USB IN transfer is complete and endpoint RAM data is available for firmware access. USB IN tokens for the endpoint are NAK'd while  $BUSY=0$  (the firmware is still loading data into the endpoint buffer).

A 1-to-0 transition of  $BUSY$  (indicating that the firmware can access the buffer) generates an interrupt request for the IN endpoint. After the firmware writes the data to be transferred to the IN endpoint buffer, it loads the endpoint's byte count register with the number of bytes to transfer, which automatically sets  $BUSY=1$ . This enables the IN transfer of data to the host in response to the next IN token. Again, the CPU should never load endpoint data while  $BUSY=1$ .

The firmware writes a "1" to an IN endpoint busy bit to disarm a previously armed endpoint. (This sets  $BUSY=0$ .) The firmware should do this only after a USB bus reset, or when the host selects a new interface or alternate setting that uses the endpoint. This prevents stale data from a previous setting from being accepted by the host's first IN transfer that uses the new setting.

## Bit 0

## STALL

## *OUT/IN Endpoint Stalled*

Each bulk endpoint (IN or OUT) has a STALL bit in its Control and Status Register (bit 0). If the CPU sets this bit, any requests to the endpoint return a STALL handshake rather than ACK or NAK. The Get Status-Endpoint Request returns the STALL state for the endpoint indicated in byte 4 of the request. Note that bit 7 of the endpoint number EP (byte 4) specifies direction.

### 15.11.9 Endpoint 2 Control and Status

EP2CS		Endpoint 2 Control and Status						E6A3
b7	b6	b5	b4	b3	b2	b1	b0	
<b>0</b>	<b>NPAK2</b>	<b>NPAK1</b>	<b>NPAK0</b>	<b>FULL</b>	<b>EMPTY</b>	<b>0</b>	<b>STALL</b>	
R	R	R	R	R	R	R	R/W	
0	0	1	0	1	0	0	0	

Figure 15-77. Endpoint 2 Control and Status

**Bit 6-4 NPAK2:0** *Number of Packets in FIFO*

The number of packets in the FIFO. 0-4 Packets.

**Bit 3 FULL** *Endpoint FIFO Full*

This bit is set to “1” to indicate that the Endpoint FIFO is full.

**Bit 2 EMPTY** *Endpoint FIFO Empty*

This bit is set to “1” to indicate that the Endpoint FIFO is empty.

**Bit 0 STALL** *ENDPOINT STALL*

Set this bit to “1” to *stall* an endpoint, and to “0” to clear a stall.

When the stall bit is “1,” the USB core returns a STALL handshake for all requests to the endpoint. This notifies the host that something unexpected has happened.

### 15.11.10 Endpoint 4 Control and Status

EP4CS		Endpoint 4 Control and Status						E6A4
b7	b6	b5	b4	b3	b2	b1	b0	
<b>0</b>	<b>0</b>	<b>NPAK1</b>	<b>NPAK0</b>	<b>FULL</b>	<b>EMPTY</b>	<b>0</b>	<b>STALL</b>	
R	R	R	R	R	R	R	R/W	
0	0	1	0	1	0	0	0	

Figure 15-78. Endpoint 4 Control and Status

**Bit 5-4**                      **NPAK1:0**    *Number of Packets in FIFO*  
 The number of packets in the FIFO. 0-2 Packets.

**Bit 3**                              **FULL**    *Endpoint FIFO Full*  
 This bit is set to “1” to indicate that the Endpoint FIFO is full.

**Bit 2**                              **EMPTY**    *Endpoint FIFO Empty*  
 This bit is set to “1” to indicate that the Endpoint FIFO is empty.

**Bit 0**                              **STALL**    *ENDPOINT STALL*  
 Set this bit to “1” to *stall* an endpoint, and to “0” to clear a stall.

When the stall bit is “1,” the USB core returns a STALL handshake for all requests to the endpoint. This notifies the host that something unexpected has happened.

### 15.11.11 Endpoint 6 Control and Status

EP6CS                              Endpoint 6 Control and Status                              E6A5							
b7	b6	b5	b4	b3	b2	b1	b0
<b>0</b>	<b>NPAK2</b>	<b>NPAK1</b>	<b>NPAK0</b>	<b>FULL</b>	<b>EMPTY</b>	<b>0</b>	<b>STALL</b>
R	R	R	R	R	R	R	R/W
0	0	0	0	0	1	0	0

Figure 15-79. Endpoint 6 Control and Status

**Bit 6-4**                              **NPAK2:0**    *Number of Packets in FIFO*  
 The number of packets in the FIFO. 0-4 Packets.

**Bit 3**                                      **FULL**    *Endpoint FIFO Full*  
 This bit is set to “1” to indicate that the Endpoint FIFO is full.

**Bit 2**                                      **EMPTY**    *Endpoint FIFO Empty*  
 This bit is set to “1” to indicate that the Endpoint FIFO is empty.

**Bit 0**                                      **STALL**    *ENDPOINT STALL*  
 Set this bit to “1” to *stall* an endpoint, and to “0” to clear a stall.

When the stall bit is “1,” the USB core returns a STALL handshake for all requests to the endpoint. This notifies the host that something unexpected has happened.

### 15.11.12 Endpoint 8 Control and Status

EP8CS		Endpoint 8 Control and Status						E6A6
b7	b6	b5	b4	b3	b2	b1	b0	
0	0	NPAK1	NPAK0	FULL	EMPTY	0	STALL	
R	R	R	R	R	R	R	R/W	
0	0	0	0	0	1	0	0	

Figure 15-80. Endpoint 8 Control and Status

**Bit 5-4**                    **NPAK1:0**    *Number of Packets in FIFO*

The number of packets in the FIFO. 0-2 Packets.

**Bit 3**                    **FULL**    *Endpoint FIFO Full*

This bit is set to “1” to indicate that the Endpoint FIFO is full.

**Bit 2**                    **EMPTY**    *Endpoint FIFO Empty*

This bit is set to “1” to indicate that the Endpoint FIFO is empty.

**Bit 0**                    **STALL**    *ENDPOINT STALL*

Set this bit to “1” to *stall* an endpoint, and to “0” to clear a stall.

When the stall bit is “1,” the USB core returns a STALL handshake for all requests to the endpoint. This notifies the host that something unexpected has happened.

### 15.11.13 Endpoint 2 and 4 Slave FIFO Flags

<b>EP2FIFOFLGS</b>	<b>Endpoint 2 Slave FIFO Flags</b>	<b>E6A7</b>
<b>EP4FIFOFLGS</b>	<b>Endpoint 4 Slave FIFO Flags</b>	<b>E6A8</b>

b7	b6	b5	b4	b3	b2	b1	b0
<b>0</b>	<b>0</b>	<b>0</b>	<b>0</b>	<b>0</b>	<b>PF</b>	<b>EF</b>	<b>FF</b>
R	R	R	R	R	R	R	R
0	0	0	0	0	0	1	0

Figure 15-81. Endpoint 2 and 4 Slave FIFO Flags

**Bit 2**                      **PF**    *Programmable Flag*

State of the EP2/EP4 Programmable Flag.

**Bit 1**                      **EF**    *Empty Flag*

State of the EP2/EP4 Empty Flag.

**Bit 0**                      **FF**    *Full Flag*

State of the EP2/EP4 Full Flag.



*FIFOPINPOLAR settings do not affect the behavior of these bits.*

### 15.11.14 Endpoint 6 and 8 Slave FIFO Flags

<b>EP6FIFOFLGS</b>	<b>Endpoint 6 Slave FIFO Flags</b>	<b>E6A9</b>
<b>EP8FIFOFLGS</b>	<b>Endpoint 8 Slave FIFO Flags</b>	<b>E6AA</b>

b7	b6	b5	b4	b3	b2	b1	b0
<b>0</b>	<b>0</b>	<b>0</b>	<b>0</b>	<b>0</b>	<b>PF</b>	<b>EF</b>	<b>FF</b>
R	R	R	R	R	R	R	R
0	0	0	0	0	1	1	0

Figure 15-82. Endpoint 6 and 8 Slave FIFO Flags

**Bit 2**                      **PF**    *Programmable Flag*

State of the EP6/EP8 Programmable Flag.



*The default value is different from EP2FIFOFLGS.PF and EP4FIFOFLGS.PF.*

**Bit 1**                      **EF**    *Empty Flag*

State of the EP6/EP8 Empty Flag.

**Bit 0**                      **FF**    *Full Flag*

State of the EP6/EP8 Full Flag.



*FIFOPINPOLAR settings do not affect the behavior of these bits.*

**15.11.15 Endpoint 2 Slave FIFO Byte Count High**

**EP2FIFOBCH                      Endpoint 2 Slave FIFO Total Byte Count HIGH                      E6AB**

b7	b6	b5	b4	b3	b2	b1	b0
<b>0</b>	<b>0</b>	<b>0</b>	<b>BC12</b>	<b>BC11</b>	<b>BC10</b>	<b>BC9</b>	<b>BC8</b>
R	R	R	R	R	R	R	R
0	0	0	0	0	0	0	0

*Figure 15-83. Endpoint 2 Slave FIFO Total Byte Count High*

**Bit 4-0**                      **BC12:8**    *Byte Count High*

Total number of bytes in Endpoint FIFO. Maximum of 4096 bytes.

**15.11.16 Endpoint 6 Slave FIFO Total Byte Count High**

**EP6FIFOBCH                      Endpoint 6 Slave FIFO Total Byte Count HIGH                      E6AF**

b7	b6	b5	b4	b3	b2	b1	b0
<b>0</b>	<b>0</b>	<b>0</b>	<b>0</b>	<b>BC11</b>	<b>BC10</b>	<b>BC9</b>	<b>BC8</b>
R	R	R	R	R	R	R	R
0	0	0	0	0	0	0	0

*Figure 15-84. Endpoint 6 Slave FIFO Total Byte Count High*

**Bit 3-0**

**BC11:8**

*Byte Count High*

Total number of bytes in Endpoint FIFO. Maximum of 2048 bytes.

**15.11.17 Endpoint 4 and 8 Slave FIFO Byte Count High**

<b>EP4FIFOBCH</b>	<b>Endpoint 4 Slave FIFO Total Byte Count HIGH</b>	<b>E6AD</b>
<b>EP8FIFOBCH</b>	<b>Endpoint 8 Slave FIFO Total Byte Count HIGH</b>	<b>E6B1</b>

b7	b6	b5	b4	b3	b2	b1	b0
<b>0</b>	<b>0</b>	<b>0</b>	<b>0</b>	<b>0</b>	<b>BC10</b>	<b>BC9</b>	<b>BC8</b>
R	R	R	R	R	R	R	R
0	0	0	0	0	0	0	0

*Figure 15-85. Endpoint 4 and 8 Slave FIFO Byte Count High*

**Bit 2-0**

**BC10:8**

*Byte Count High*

Total number of bytes in Endpoint FIFO. Maximum of 1024 bytes.

**15.11.18 Endpoint 2, 4, 6, 8 Slave FIFO Byte Count Low**

<b>EP2FIFOBCL</b>	<b>Endpoint 2 Slave FIFO Total Byte Count LOW</b>	<b>E6AC</b>
<b>EP4FIFOBCL</b>	<b>Endpoint 4 Slave FIFO Total Byte Count LOW</b>	<b>E6AE</b>
<b>EP6FIFOBCL</b>	<b>Endpoint 6 Slave FIFO Total Byte Count LOW</b>	<b>E6B0</b>
<b>EP8FIFOBCL</b>	<b>Endpoint 8 Slave FIFO Total Byte Count LOW</b>	<b>E6B2</b>

b7	b6	b5	b4	b3	b2	b1	b0
<b>BC7</b>	<b>BC6</b>	<b>BC5</b>	<b>BC4</b>	<b>BC3</b>	<b>BC2</b>	<b>BC1</b>	<b>BC0</b>
R	R	R	R	R	R	R	R
0	0	0	0	0	0	0	0

*Figure 15-86. Endpoint 2, 4, 6, 8 Slave FIFO Byte Count Low*

**Bit 7-0**

**BC7:0**

*Byte Count High*

Low byte for number of bytes in Endpoint FIFO.

**15.11.19 Setup Data Pointer High and Low Address****SUDPTRH                      Setup Data Pointer High Address Byte                      E6B3**

b7	b6	b5	b4	b3	b2	b1	b0
<b>A15</b>	<b>A14</b>	<b>A13</b>	<b>A12</b>	<b>A11</b>	<b>A10</b>	<b>A9</b>	<b>A8</b>
R/W	R/W	R/W	R/W	R/W	R/W	R/W	R/W
x	x	x	x	x	x	x	x

*Figure 15-87. Setup Data Pointer High Address Byte***SUDPTRL                      Setup Data Pointer Low Address Byte                      E6B4**

b7	b6	b5	b4	b3	b2	b1	b0
<b>A7</b>	<b>A6</b>	<b>A5</b>	<b>A4</b>	<b>A3</b>	<b>A2</b>	<b>A1</b>	<b>A0</b>
R/W	R/W	R/W	R/W	R/W	R/W	R/W	R
x	x	x	x	x	x	x	0

*Figure 15-88. Setup Data Pointer Low Address Byte***Bit 15-0****A15:0***Setup Data Pointer*

This buffer is used as a target or source by the Setup Data Pointer and it must be WORD (2-byte) aligned. This 16-bit pointer, SUDPTRH:L provides hardware assistance for handling CONTROL IN transfers.

When the firmware loads SUDPTRL, the SIE automatically responds to IN commands with the appropriate data. If SDPAUTO=1, the length field is taken from the packet or descriptor. If SDPAUTO=0, SUDPTRL triggers a send to the host and the length is taken from the EP0BCH and EP0BCL bytes.



## 15.11.20 Setup Data Pointer Auto

### SUDPTRCTL Setup Data Pointer AUTO Mode E6B5

b7	b6	b5	b4	b3	b2	b1	b0
0	0	0	0	0	0	0	<b>SDPAUTO</b>
R/W	R/W	R/W	R/W	R/W	R/W	R/W	R/W
0	0	0	0	0	0	0	1

Figure 15-89. Setup Data Pointer AUTO Mode

#### Bit 0 SDPAUTO Setup Data Pointer Auto Mode

To send a block of data using the Setup Data Pointer, the block's starting address is loaded into SUDPTRH:L. The block length must previously have been set; the method for accomplishing this depends on the state of the SDPAUTO bit:

- **SDPAUTO = 0 (Manual Mode):** Used for general-purpose block transfers. Firmware writes the block length to EP0BCH:L.
- **SDPAUTO = 1 (Auto Mode):** Used for sending Device, Configuration, String, Device Qualifier, and Other Speed Configuration descriptors *only*. The block length is automatically read from the "length" field of the descriptor itself; no explicit loading of EP0BCH:L is necessary.

Writing to SUDPTRL starts the transfer; the FX2 automatically sends the entire block, packetizing as necessary.



*When SDPAUTO = 0, writing to EP0BCH:L only sets the block length; it does not arm the transfer (the transfer is armed by writing to SUDPTRL). Therefore, before performing an EP0 transfer which does **not** use the Setup Data Pointer (i.e., one which is meant to be armed by writing to EP0BCL), SDPAUTO **must** be set to 1.*

**15.11.21 Setup Data - 8 Bytes**

<b>SETUPBUF</b>		<b>8 Bytes of Setup Data</b>				<b>E6B8-E6BF</b>	
b7	b6	b5	b4	b3	b2	b1	b0
<b>D7</b>	<b>D6</b>	<b>D5</b>	<b>D4</b>	<b>D3</b>	<b>D2</b>	<b>D1</b>	<b>D0</b>
R	R	R	R	R	R	R	R
x	x	x	x	x	x	x	x

*Figure 15-90. Setup Data - 8 Bytes*

The setup data bytes are defined as follows:

SETUPDAT[0] = bmRequestType

SETUPDAT[1] = bmRequest

SETUPDAT[2:3] = wValue

SETUPDAT[4:5] = wIndex

SETUPDAT[6:7] = wLength

This buffer contains the 8 bytes of SETUP packet data from the most recently received CONTROL transfer.

The data in SETUPBUF is valid when the SUDAV (Setup Data Available) Interrupt Request bit is set.

## 15.12 General Programmable Interface (GPIF)

### 15.12.1 GPIF Waveform Selector

GPIFWFSELECT							Waveform Selector	E6C0
b7	b6	b5	b4	b3	b2	b1	b0	
<b>SINGLEWR1</b>	<b>SINGLEWR0</b>	<b>SINGLERD1</b>	<b>SINGLERD0</b>	<b>FIFOWR1</b>	<b>FIFOWR0</b>	<b>FIFORD1</b>	<b>FIFORD0</b>	
R/W	R/W	R/W	R/W	R/W	R/W	R/W	R/W	
1	1	1	0	0	1	0	0	

Figure 15-91. GPIF Waveform Selector

**Bit 7-6**                      **SINGLEWR1:0**                      *Single Write Waveform Index*

Index to the Waveform Program to run when a “Single Write” is triggered by the firmware.

**Bit 5-4**                      **SINGLERD1:0**                      *Single Read Waveform Index*

Index to the Waveform Program to run when a “Single Read” is triggered by the firmware.

**Bit 3-2**                      **FIFOWR1:0**                      *FIFO Write Waveform Index*

Index to the Waveform Program to run when a “FIFO Write” is triggered by the firmware.

**Bit 1-0**                      **FIFORD1:0**                      *FIFO Read Waveform Index*

Index to the Waveform Program to run when a “FIFO Read” is triggered by the firmware.  
Select waveform 0 [00], 1 [01], 2 [10] or 3 [11].

### 15.12.2 GPIF Done and Idle Drive Mode

GPIFIDLECS							GPIF Done, GPIF Idle Drive Mode	E6C1
b7	b6	b5	b4	b3	b2	b1	b0	
<b>DONE</b>	<b>0</b>	<b>0</b>	<b>0</b>	<b>0</b>	<b>0</b>	<b>0</b>	<b>IDLEDRV</b>	
R/W	R/W	R/W	R/W	R/W	R/W	R/W	R/W	
1	0	0	0	0	0	0	0	

Figure 15-92. GPIF Done and Idle Drive

**Bit 7**                      **DONE**                                      *GPIF Idle State*

0 = Transaction in progress.  
 1 = Transaction Done (GPIF is idle, hence GPIF is ready for next Transaction). Fires IRQ4 if enabled.

**Bit 0**                      **IDLEDRV**                                      *Set Data Bus when GPIF Idle*

When the GPIF is idle:  
 0 = Tri-state the Data Bus.  
 1 = Drive the Data Bus.

**15.12.3 CTL Outputs**

**GPIFIDLECTL                      CTL Output States in Idle                      E6C2**

b7	b6	b5	b4	b3	b2	b1	b0
<b>0/ CTLOE3</b>	<b>0/ CTLOE2</b>	<b>CTL5/ CTLOE1</b>	<b>CTL4/ CTLOE0</b>	<b>CTL3</b>	<b>CTL2</b>	<b>CTL1</b>	<b>CTL0</b>
R/W	R/W	R/W	R/W	R/W	R/W	R/W	R/W
1	1	1	1	1	1	1	1

*Figure 15-93. CTL Output States in Idle*

**Bit 7-4**                      **CTLOE3:0**                                      *CTL Output Enables*  
**Bit 5-0**                      **CTL5:0**                                      *CTL Output States*

See GPIFCTLCFG, below.

**GPIFCTLCFG                      CTL Output Drive Type                      E6C3**

b7	b6	b5	b4	b3	b2	b1	b0
<b>TRICTL</b>	<b>0</b>	<b>CTL5</b>	<b>CTL4</b>	<b>CTL3</b>	<b>CTL2</b>	<b>CTL1</b>	<b>CTL0</b>
R/W	R/W	R/W	R/W	R/W	R/W	R/W	R/W
0	0	0	0	0	0	0	0

*Figure 15-94. CTL Output Drive Type*

**Bit 7**                      **TRICTL**                                      *Number Active Outputs/Tristating*  
**Bit 5-0**                      **CTL5:0**                                      *CTL Output Drive Type*

The GPIF Control pins (CTL[5:0]) have several output modes:

- CTL[3:0] can act as CMOS outputs (optionally tristatable) or open-drain outputs.
- CTL[5:4] can act as CMOS outputs or open-drain outputs.  
If CTL[3:0] are configured to be tristatable, CTL[5:4] are not available.

*Table 15-16. CTL[5:0] Output Modes*

TRICTL (GPIFCTLCFG.7)	GPIFCTLCFG[6:0]	CTL[3:0]	CTL[5:4]
0	0	CMOS, Not Tristatable	CMOS, Not Tristatable
0	1	Open-Drain	Open-Drain
1	X	CMOS, Tristatable	Not Available

During the IDLE State, the state of CTL[5:0] depends on the following register bits:

- TRICTL (GPIFCTLCFG.7).
- GPIFCTLCFG[5:0]
- GPIFIDLECTL[5:0].

The combination of these bits defines CTL5:0 during IDLE as follows:

- If TRICTL is 0, GPIFIDLECTL[5:0] directly represent the output states of CTL5:0 during the IDLE State. The GPIFCTLCFG[5:0] bits determine whether the CTL5:0 outputs are CMOS or open-drain: If GPIFCTLCFG.x = 0, CTLx is CMOS; if GPIFCTLCFG.x = 1, CTLx is open-drain.
- If TRICTL is 1, GPIFIDLECTL[7:4] are the output enables for the CTL[3:0] signals, and GPIFIDLECTL[3:0] are the output values for CTL[3:0]. CTL4 and CTL5 are unavailable in this mode.

Table 15-17 illustrates this relationship.

Table 15-17. Control Outputs (CTLx) During the IDLE State

TRICTL	Control Output	Output State	Output Enable
0	CTL0	GPIFIDLECTL.0	N/A (CTL Outputs are always enabled when TRICTL = 0)
	CTL1	GPIFIDLECTL.1	
	CTL2	GPIFIDLECTL.2	
	CTL3	GPIFIDLECTL.3	
	CTL4	GPIFIDLECTL.4	
	CTL5	GPIFIDLECTL.5	
1	CTL0	GPIFIDLECTL.0	GPIFIDLECTL.4
	CTL1	GPIFIDLECTL.1	GPIFIDLECTL.5
	CTL2	GPIFIDLECTL.2	GPIFIDLECTL.6
	CTL3	GPIFIDLECTL.3	GPIFIDLECTL.7
	CTL4	N/A (CTL4 and CTL5 are not available when TRICTL = 1)	
	CTL5		

### 15.12.4 GPIF Address High

<b>GPIFADRH</b> <i>see Section 15.14</i>	<b>GPIF Address High</b>	<b>E6C4</b>
---	--------------------------	-------------

b7	b6	b5	b4	b3	b2	b1	b0
<b>0</b>	<b>0</b>	<b>0</b>	<b>0</b>	<b>0</b>	<b>0</b>	<b>0</b>	<b>GPIFA8</b>
R/W	R/W	R/W	R/W	R/W	R/W	R/W	R/W
0	0	0	0	0	0	0	0

Figure 15-95. GPIF Address High

**Bit 0**

**GPIF A8**

*High Bit of GPIF Address*

See GPIFADDRL.

### 15.12.5 GPIF Address Low

**GPIFADRL** **GPIF Address Low** **E6C5**  
*see Section 15.14*

b7	b6	b5	b4	b3	b2	b1	b0
<b>GPIFA7</b>	<b>GPIFA6</b>	<b>GPIFA5</b>	<b>GPIFA4</b>	<b>GPIFA3</b>	<b>GPIFA2</b>	<b>GPIFA1</b>	<b>GPIFA0</b>
R/W	R/W	R/W	R/W	R/W	R/W	R/W	R/W
0	0	0	0	0	0	0	0

Figure 15-96. GPIF Address Low

**Bit 7-0** **GPIFA7:0** *Lower 8 bits of GPIF Address*

Data written to this register immediately appears as the bus address on the ADR[7:0] pins.

### 15.12.6 GPIF Flowstate Registers

For complete Flowstate / UDMA information, please contact the Cypress Semiconductor Applications Department.

**FLOWSTATE** **E6C6**

b7	b6	b5	b4	b3	b2	b1	b0
<b>FSE</b>	<b>0</b>	<b>0</b>	<b>0</b>	<b>0</b>	<b>FS[2:0]</b>		
0	0	0	0	0	0	0	0
RW	R	R	R	R	RW	RW	RW

Any one (and only one) of the seven GPIF states in a waveform can be programmed to be the flow state. This register defines which state, if any, in the next invoked GPIF waveform will be the flow state.

**Bit 7** **FSE** *Global Flow State Enable*

Global enable for the flow state. When it is disabled all flow state registers are don't care and the next waveform invocation will not cause a flow state to be used.

**Bit 2-0** **FS[2:0]** *Flow State Selection*

Defines which GPIF state is the flow state. Valid values are 0-6.\

**FLOWLOGIC****E6C7**

b7	b6	b5	b4	b3	b2	b1	b0
<b>LFUNC[1:0]</b>		<b>TERMA[2:0]</b>			<b>TERMB[2:0]</b>		
0	0	0	0	0	0	0	0
RW	RW	RW	RW	RW	RW	RW	RW

The bit definitions for this register are analogous to the bit definitions in the RDY LOGIC opcode in a waveform descriptor. Except, instead of controlling the branching for a decision point, it controls the freezing or flowing of data on the bus in a flow state.

The user defines the states of CTL[5:0] for when the flow logic equals 0 and 1 (see FLOWEQ0\_CTL and FLOWEQ1\_CTL). This is useful in activating or deactivating protocol ready signals to hold off an external master (where the GPIF is acting like a slave) in response to internal FIFO flags warning of an impending underflow or overflow situation.

In the case where the GPIF is the master, then the user also defines whether Master Strobe (a CTL pin in this case; see FLOWSTB) toggles (reads or writes data on the bus) when the flow logic evaluates to a 1 or a 0. This is useful for the GPIF to consider protocol ready signals from the slave as well as FIFO flags to decide when to clock data out of or into the FIFOs and when to freeze the data flow instead.

It should be noted that this flow logic does not replace the decision point logic defined in a waveform descriptor. The decision point logic in a waveform descriptor is still used to decide when to branch out of the flow state. The decision point logic can use an entirely different pair of ready signals than the flow logic in making its decisions.

**Bits 7-6****LFUNC[1:0]***Flow State Logic Function*

00 = A AND B  
 01 = A OR B  
 10 = A XOR B  
 11 = !A AND B

Since the flow logic decision can be based on the output being a 1 or a 0, NAND, NOR, XNOR and !(A AND B) operations can be achieved as well. Note that !(A AND B) is the same as (A OR !B).



**Bits 5-3**

**TERMA[2:0]**

*Flow State Logic-Function Arguments*

**Bits 2-0**

**TERMB[2:0]**

0 = RDY[0]

1 = RDY[1]

2 = RDY[2]

3 = RDY[3]

4 = RDY[4]

5 = RDY[5] or TC-Expiration (depending on GPIF\_READYCFG.5)

6 = FIFO Flag (PF, EF, or FF depending on GPIF\_EPxFLAGSEL)

7 = 8051 RDY (GPIF\_READYCFG.7)

## FLOWEQ0CTL

**E6C8**

b7	b6	b5	b4	b3	b2	b1	b0
<b>CTLOE3</b>	<b>CTLOE2</b>	<b>CTLOE1/ CTL5</b>	<b>CTLOE0/ CTL4</b>	<b>CTL3</b>	<b>CTL2</b>	<b>CTL1</b>	<b>CTL0</b>
0	0	0	0	0	0	0	0
RW	RW	RW	RW	RW	RW	RW	RW

## FLOWEQ1CTL

**E6C9**

b7	b6	b5	b4	b3	b2	b1	b0
<b>CTLOE3</b>	<b>CTLOE2</b>	<b>CTLOE1/ CTL5</b>	<b>CTLOE0/ CTL4</b>	<b>CTL3</b>	<b>CTL2</b>	<b>CTL1</b>	<b>CTL0</b>
0	0	0	0	0	0	0	0
RW	RW	RW	RW	RW	RW	RW	RW

FLOWEQ0CTL defines the state of the CTL5:0 pins when the output of the flow logic equals 0; FLOWEQ1CTL defines the state when the logic output equals 1. During a flow state, the CTL opcode in the waveform descriptor is completely ignored and the behavior of the CTL[5:0] pins are defined by these two registers instead.

**CTLOEx Bit:** If TRICTL = 1, CTL5:4 are unused and CTLOE3:0 specifies whether the corresponding CTL3:0 output signals are tristated.

1 = Drive CTLx

0 = Tristate CTLx

**CTLx Bit:** specifies the state to set each CTLx signal to during this entire State.

1 = High level

If the CTLx bit in the GPIFCTLCFG register is set to 1, the output driver will be an open-drain.

If the CTLx bit in the GPIFCTLCFG register is set to 0, the output driver will be driven to CMOS levels.

0 = Low level

defined by FLOWEQxCTL and these bits, instead:

- TRICTL (GPIFCTLCFG.7), as described in Section 10.2.3.1, "Control Output Modes".
- GPIFCTLCFG[5:0].

The combination of these bits defines CTL5:0 during a Flow State as follows:

- If TRICTL is 0, FLOWEQxCTL[5:0] directly represent the output states of CTL5:0 during the Flow State. The GPIFCTLCFG[5:0] bits determine whether the CTL5:0 outputs are CMOS or open-drain: If GPIFCTLCFG.x = 0, CTLx is CMOS; if GPIFCTLCFG.x = 1, CTLx is open-drain.
- If TRICTL is 1, FLOWEQxCTL[7:4] are the output enables for the CTL[3:0] signals, and FLOWEQxCTL[3:0] are the output values for CTL[3:0]. CTL4 and CTL5 are unavailable in this mode.

Table 15-17 illustrates this relationship.

Table 15-18. Control Outputs (CTLx) During the Flow State

TRICTL	Control Output	Output State	Drive Type (0 = CMOS, 1 = Open-Drain)	Output Enable	
0	CTL0	FLOWEQxCTL.0	GPIFCTLCFG.0	N/A (CTL Outputs are always enabled when TRICTL = 0)	
	CTL1	FLOWEQxCTL.1	GPIFCTLCFG.0		
	CTL2	FLOWEQxCTL.2	GPIFCTLCFG.0		
	CTL3	FLOWEQxCTL.3	GPIFCTLCFG.0		
	CTL4	FLOWEQxCTL.4	GPIFCTLCFG.0		
	CTL5	FLOWEQxCTL.5	GPIFCTLCFG.0		
1	CTL0	FLOWEQxCTL.0	N/A (CTL Outputs are always tristatable CMOS when TRICTL = 1)	FLOWEQxCTL.4	
	CTL1	FLOWEQxCTL.1		FLOWEQxCTL.5	
	CTL2	FLOWEQxCTL.2		FLOWEQxCTL.6	
	CTL3	FLOWEQxCTL.3		FLOWEQxCTL.7	
	CTL4	N/A			(CTL4 and CTL5 are not available when TRICTL = 1)
	CTL5				

## FLOWSTB

E6CB

b7	b6	b5	b4	b3	b2	b1	b0
<b>SLAVE</b>	<b>RDYASYN</b>	<b>CTLTOGL</b>	<b>SUSTAIN</b>	<b>0</b>	<b>MSTB[2:0]</b>		
0	0	1	0	0	0	0	0
RW	RW	RW	RW	R	RW	RW	RW

\* - based on suggested FLOW\_LOGIC settings.

This register defines the Master Strobe that causes data to be read or written during a flow state.

For transactions where GPIF is the slave on the bus, the Master Strobe will be one of the RDY[5:0] pins. This includes external masters that can either write data into GPIF (e.g., UDMA IN) or read data out of GPIF.

For transactions where GPIF is the master on the bus, the Master Strobe will be one of the CTL[5:0] pins. This includes cases where the GPIF writes data out to a slave (e.g., UDMA OUT) or reads data from a slave.

### Bit 7 SLAVE

0: GPIF is the master of the bus transaction. This means that one of the CTL[5:0] pins will be the Master Strobe and the particular one is selected by MSTB[2:0].

1: GPIF is the slave of the bus transaction. This means that one of the RDY[5:0] pins will be the Master Strobe and the particular one is selected by MSTB[2:0].

**Bit 6 RDYASYNC**

If SLAVE is 0 then this bit is ignored, otherwise:

0: Master Strobe (which is a RDY pin in this case) is asynchronous to IFCLK.

1: Master Strobe (which is a RDY pin in this case) is synchronous to IFCLK.

**Bit 5 CTLTOGL**

If SLAVE is 1 then this bit is ignored. Otherwise, this bit defines which state of the flow logic (see FLOWLOGIC) causes Master Strobe (which will be a CTL pin in this case) to toggle. For example, if this bit is set to 1, then if the output of the flow logic equals 1 then Master Strobe will toggle causing data to flow on the bus. If in the same example the output of the flow logic equals 0 then Master Strobe will freeze causing data flow to halt on the bus.

**Bit 4 SUSTAIN**

If SLAVE is 1 then this bit is ignored.



*Upon exiting a flow state in which SLAVE is 0, Master Strobe (which is a CTL pin in this case) will normally go back to adhering to the CTL opcodes defined in the waveform descriptor.*

**Bit 2-0 MSTB[2:0]**

If SLAVE is 0 then these bits will select which CTL[5:0] pin is the Master Strobe. If SLAVE is 1 then these bits will select which RDY[5:0] pin is the Master Strobe.

**FLOWHOLDOFF E6CA**

b7	b6	b5	b4	b3	b2	b1	b0
<b>HOPERIOD[3:0]</b>				<b>HOSTATE</b>	<b>HOCTL[2:0]</b>		
RW	RW	RW	RW	RW	RW	RW	RW
0	0	0	1	0	0	1	0

For flow state transactions that meet the following criteria:

1. The interface is asynchronous.
2. GPIF is acting like a slave (FLOWSTB.SLAVE = 1), and thus Master Strobe is a RDY pin.
3. data is being written into the GPIF.



**FLOWSTBPERIOD****E6CD**

b7	b6	b5	b4	b3	b2	b1	b0
<b>D7</b>	<b>D6</b>	<b>D5</b>	<b>D4</b>	<b>D3</b>	<b>D2</b>	<b>D1</b>	<b>D0</b>
RW	RW	RW	RW	RW	RW	RW	RW
0	0	0	0	0	0	1	0

If the flow state is such that the GPIF is the master on the bus (FLOWSTB.SLAVE = 0) then Master Strobe will be one of the CTL[5:0] pins (see FLOWSTB). While in the flow state, if the flow logic (see FLOWLOGIC) evaluates in such a way that Master Strobe should toggle (see FLOWSTB.CTLTOGL), then this register defines the frequency at which it will toggle.

More precisely, this register defines the half period of the Master Strobe toggling frequency. Further, to give the user a high degree of resolution this Master Strobe half period is defined in terms of half IFCLK periods. Therefore, if IFCLK is running at 48 MHz, this gives a resolution of 10.8 nS.

**Bits 7-0****D7:0***Master Strobe Half-Period*

Number of *half* IFCLK periods that define the half period of Master Strobe (if it is a CTL pin). Value must be at least 2, meaning that the minimum half period for Master Strobe is one full IFCLK cycle.

**GPIFHOLDTIME****E60C**

b7	b6	b5	b4	b3	b2	b1	b0
<b>0</b>	<b>0</b>	<b>0</b>	<b>0</b>	<b>0</b>	<b>0</b>	<b>HOLDTIME[1:0]</b>	
R	R	R	R	R	R	RW	RW
0	0	0	0	0	0	0	0

For any transaction where the GPIF writes data onto FD[15:0], this register determines how long the data is held. Valid choices are 0, ½ or 1 IFCLK cycle. This register applies to *any* data written by the GPIF to FD[15:0], whether through a flow state or not.

For non-flow states, the hold amount is really just a delay of the normal (non-held) presentation of FD[15:0] by the amount specified in HOLDTIME[1:0].

For flow states in which the GPIF is the master on the bus (FLOWSTB.SLAVE = 0), the hold amount is with respect to the activating edge (see FLOW\_MASTERSTB\_EDGE) of Master Strobe (which will be a CTL pin in this case).

For flow states in which the GPIF is the slave on the bus (FLOWSTB.SLAVE = 1), the hold amount is really just a delay of the normal (non-held) presentation of FD[15:0] by the amount specified in HOLDTIME[1:0] in reaction to the activating edge of Master Strobe (which will be a RDY pin in this case). Note the hold amount is NOT *directly* with respect to the activating edge of Master Strobe in

this case. It is with respect to when the data would normally come out in response to Master Strobe including any latency to synchronize Master Strobe.

In all cases, the data will be held for the desired amount even if the ensuing GPIF state calls for the data bus to be tristated. In other words the FD[15:0] output enable will be held by the same amount as the data itself.

<b>Bits 1-0</b>	<b>HOLDTIME[1:0]</b>	<i>GPIF Hold Time</i>
	00 = 0 IFCLK cycles	
	01 = ½ IFCLK cycle	
	10 = 1 IFCLK cycle	
	11 = reserved	

### 15.12.7 Endpoint 2, 4, 6, 8 GPIF Transaction Count High

<b>EP2GPIFTCH</b>	<b>Endpoint 2 GPIF Transaction Count High</b>	<b>E6D0</b>
<b>EP4GPIFTCH</b>	<b>Endpoint 4 GPIF Transaction Count High</b>	<b>E6D8</b>
<b>EP6GPIFTCH</b>	<b>Endpoint 6 GPIF Transaction Count High</b>	<b>E6E0</b>
<b>EP8GPIFTCH</b>	<b>Endpoint 8 GPIF Transaction Count High</b>	<b>E6E8</b>

b7	b6	b5	b4	b3	b2	b1	b0
<b>TC15</b>	<b>TC14</b>	<b>TC13</b>	<b>TC12</b>	<b>TC11</b>	<b>TC10</b>	<b>TC9</b>	<b>TC8</b>
R/W	R/W	R/W	R/W	R/W	R/W	R/W	R/W
0	0	0	0	0	0	0	0

Figure 15-97. Endpoint 2, 4, 6, 8 GPIF Transaction Count High

<b>Bit 7-0</b>	<b>TC15:8</b>	<i>High Byte for Transaction Count</i>
	See EPxGPIFTCL.	

**15.12.8 Endpoint 2, 4, 6, 8 GPIF Transaction Count Low**

<b>EP2GPIFTCL</b>	<b>Endpoint 2 GPIF Transaction Count Low</b>	<b>E6D1</b>
<b>EP4GPIFTCL</b>	<b>Endpoint 4 GPIF Transaction Count Low</b>	<b>E6D9</b>
<b>EP6GPIFTCL</b>	<b>Endpoint 6 GPIF Transaction Count Low</b>	<b>E6E1</b>
<b>EP8GPIFTCL</b>	<b>Endpoint 8 GPIF Transaction Count Low</b>	<b>E6E9</b>

b7	b6	b5	b4	b3	b2	b1	b0
<b>TC7</b>	<b>TC6</b>	<b>TC5</b>	<b>TC4</b>	<b>TC3</b>	<b>TC2</b>	<b>TC1</b>	<b>TC0</b>
R/W	R/W	R/W	R/W	R/W	R/W	R/W	R/W
0	0	0	0	0	0	0	0

*Figure 15-98. Endpoint 2, 4, 6, 8 GPIF Transaction Count Low*

Two methods may be used to set up the GPIF to automatically start the next transaction when the previous transaction has finished, thereby, repeatedly running Transactions that fetch (in 8-bit mode) a byte at a time or (in 16-bit mode) a word at a time. The two methods for controlling and terminating Burst Transactions (always involving FIFOs) are:

- using a FIFO's flag as pointed to by EPxGPIFFLGSEL.
- using a Transaction Count.

**Bit 7-0**

**TC7:0**

*Low Byte for Transaction Count*



### 15.12.9 Endpoint 2, 4, 6, 8 GPIF Flag Select

<b>EP2GPIFFLGSEL</b> <i>see Section 15.14</i>	<b>Endpoint 2 GPIF Flag Select</b>	<b>E6D2</b>
<b>EP4GPIFFLGSEL</b> <i>see Section 15.14</i>	<b>Endpoint 4 GPIF Flag Select</b>	<b>E6DA</b>
<b>EP6GPIFFLGSEL</b> <i>see Section 15.14</i>	<b>Endpoint 6 GPIF Flag Select</b>	<b>E6E2</b>
<b>EP8GPIFFLGSEL</b> <i>see Section 15.14</i>	<b>Endpoint 8 GPIF Flag Select</b>	<b>E6EA</b>

b7	b6	b5	b4	b3	b2	b1	b0
<b>0</b>	<b>0</b>	<b>0</b>	<b>0</b>	<b>0</b>	<b>0</b>	<b>FS1</b>	<b>FS0</b>
R/W	R/W	R/W	R/W	R/W	R/W	R/W	R/W
0	0	0	0	0	0	0	0

Figure 15-99. Endpoint 2, 4, 6, 8 GPIF Flag Select

**Bit 1-0**

**FS1:0**

*GPIF Flag Select*

Table 15-19. Endpoint 2, 4, 6, 8 GPIF Flag Select Values

<b>FS1</b>	<b>FS0</b>	<b>Flag</b>
0	0	Programmable
0	1	Empty
1	0	Full
1	1	Reserved

Only one FIFO flag at a time may be made available to the GPIF as a control input. The FS1:FS0 bits select which flag is made available.

### 15.12.10 Endpoint 2, 4, 6, and 8 GPIF Stop Transaction

<b>EP2GPIFPFSTOP</b>	<b>Endpoint 2 GPIF Stop Transaction</b>	<b>E6D3</b>
<b>EP4GPIFPFSTOP</b>	<b>Endpoint 4 GPIF Stop Transaction</b>	<b>E6DB</b>
<b>EP6GPIFPFSTOP</b>	<b>Endpoint 6 GPIF Stop Transaction</b>	<b>E6E3</b>
<b>EP8GPIFPFSTOP</b>	<b>Endpoint 8 GPIF Stop Transaction</b>	<b>E6EB</b>

b7	b6	b5	b4	b3	b2	b1	b0
0	0	0	0	0	0	0	<b>FIFO[2,4,6,8] FLAG</b>
R/W	R/W	R/W	R/W	R/W	R/W	R/W	R/W
0	0	0	0	0	0	0	0

Figure 15-100. Endpoint 2, 4, 6, and 8 GPIF Stop Transaction

**Bit 0**                      **EP[2,4,6,8]PF**                      *Stop on Endpoint Programmable Flag*

- 1= GPIF transitions to “DONE” state when the flag selected by EPxGPIFFLGSEL is asserted.
- 0= When transaction count has been met.

### 15.12.11 Endpoint 2, 4, 6, and 8 Slave FIFO GPIF Trigger

<b>EP2GPIFTRIG</b>	<b>Endpoint 2 Slave FIFO GPIF Trigger</b>	<b>E6D4</b>
<i>see Section 15.14</i>		
<b>EP4GPIFTRIG</b>	<b>Endpoint 4 Slave FIFO GPIF Trigger</b>	<b>E6DC</b>
<i>see Section 15.14</i>		
<b>EP6GPIFTRIG</b>	<b>Endpoint 6 Slave FIFO GPIF Trigger</b>	<b>E6E4</b>
<i>see Section 15.14</i>		
<b>EP8GPIFTRIG</b>	<b>Endpoint 8 Slave FIFO GPIF Trigger</b>	<b>E6EC</b>
<i>see Section 15.14</i>		

b7	b6	b5	b4	b3	b2	b1	b0
<b>x</b>	<b>x</b>	<b>x</b>	<b>x</b>	<b>x</b>	<b>x</b>	<b>x</b>	<b>x</b>
W	W	W	W	W	W	W	W
x	x	x	x	x	x	x	x

Figure 15-101. Endpoint 2, 4, 6, and 8 Slave FIFO GPIF Trigger

Write 0xFF to this register to initiate a GPIF write. Read from this register to initiate a GPIF read.

### 15.12.12 GPIF Data High (16-Bit Mode)

**XGPIFSGLDATH**      **GPIF Data HIGH (16-bit mode)**      **E6F0**

b7	b6	b5	b4	b3	b2	b1	b0
<b>D15</b>	<b>D14</b>	<b>D13</b>	<b>D12</b>	<b>D11</b>	<b>D10</b>	<b>D9</b>	<b>D8</b>
R/W	R/W	R/W	R/W	R/W	R/W	R/W	R/W
x	x	x	x	x	x	x	x

Figure 15-102. GPIF Data High (16-Bit Mode)

**Bit 7-0**                      **D15:8**                                      *GPIF Data High*

Contains the data written to or read from the FD15:8 (PORTD) pins using the GPIF waveform.

### 15.12.13 Read/Write GPIF Data LOW & Trigger Transaction

**XGPIFSGLDATLX**      **Read/Write GPIF Data LOW & Trigger Transaction**      **E6F1**

b7	b6	b5	b4	b3	b2	b1	b0
<b>D7</b>	<b>D6</b>	<b>D5</b>	<b>D4</b>	<b>D3</b>	<b>D2</b>	<b>D1</b>	<b>D0</b>
R/W	R/W	R/W	R/W	R/W	R/W	R/W	R/W
x	x	x	x	x	x	x	x

Figure 15-103. Read/Write GPIF Data LOW & Trigger Transaction

**Bit 7-0**                      **D7:0**                                      *GPIF Data Low /Trigger GPIF Transaction*

Contains the data written to or read from the FD7:0 (PORTB) pins. Reading or writing low-byte triggers a GPIF transaction.

### 15.12.14 Read GPIF Data LOW, No Transaction Trigger

<b>XGPIFSGLDATLNOX</b>	<b>Read GPIF Data LOW, No Transaction Trigger</b>	<b>E6F2</b>
------------------------	---	-------------

b7	b6	b5	b4	b3	b2	b1	b0
<b>D7</b>	<b>D6</b>	<b>D5</b>	<b>D4</b>	<b>D3</b>	<b>D2</b>	<b>D1</b>	<b>D0</b>
R	R	R	R	R	R	R	R
x	x	x	x	x	x	x	x

Figure 15-104. Read GPIF Data LOW, No Transaction Trigger

**Bit 7-0**                      **D7:0**                      *GPIF Data Low /Don't Trigger GPIF Transaction*

Contains the data written to or read from the FD7:0 (PORTB) pins. Read or write low byte does not trigger GPIF transaction.

### 15.12.15 GPIF RDY Pin Configuration

<b>GPIFREADYCFG</b>	<b>GPIF RDY Pin Configuration</b>	<b>E6F3</b>
---------------------	-----------------------------------	-------------

b7	b6	b5	b4	b3	b2	b1	b0
<b>INTRDY</b>	<b>SAS</b>	<b>TCXRDY5</b>	<b>0</b>	<b>0</b>	<b>0</b>	<b>0</b>	<b>0</b>
R/W	R/W	R/W	R	R	R	R	R
0	0	0	0	0	0	0	0

Figure 15-105. GPIF Ready Pins

**Bit 7**                      **INTRDY**                      *Force Ready Condition*

Internal RDY. Functions as a sixth RDY input, controlled by the firmware instead of a RDY pin.

**Bit 6**                      **SAS**                      *RDY Signal Connection to GPIF Input Logic*

Synchronous/Asynchronous RDY signals. This bit controls how the RDY signals connect to the GPIF input logic.

If the internal IFCLK is used to clock the GPIF, the RDY signals can make transitions in an asynchronous manner, i.e. not referenced to the internal clock. Setting SAS=1 causes the RDY inputs to pass through two flip-flops for synchronization purposes.

If the RDY signals are synchronized to IFCLK, and obey the setup and hold times with respect to this clock, the user can set SAS=0, which causes the RDY signals to pass through a single flip-flop.

**Bit 5**                      **TCXRDY5**                      *TC Expiration Replaces RDY5*

To use the transaction count expiration signal as a ready input to a waveform, set this bit to 1. Setting this bit will take the place of the pin RDY5 in the decision point of the waveform. The default value of the bit is zero (in other words, the RDY5 from the pin prevails).

---

**15.12.16 GPIF RDY Pin Status**

GPIFREADYSTAT		GPIF RDY Pin Status						E6F4
b7	b6	b5	b4	b3	b2	b1	b0	
<b>0</b>	<b>0</b>	<b>RDY5</b>	<b>RDY4</b>	<b>RDY3</b>	<b>RDY2</b>	<b>RDY1</b>	<b>RDY0</b>	
R	R	R	R	R	R	R	R	
0	0	x	x	x	x	x	x	

Figure 15-106. GPIF Ready Status Pins

**Bit 5-0**                      **RDY5:0**                      *Current State of Ready Pins*

RDYx. Instantaneous states of the RDY pins. The current state of the RDY[5:0] pins, sampled at each rising edge of the GPIF clock.

---

**15.12.17 Abort GPIF Cycles**

GPIFABORT		Abort GPIF						E6F5
b7	b6	b5	b4	b3	b2	b1	b0	
<b>x</b>	<b>x</b>	<b>x</b>	<b>x</b>	<b>x</b>	<b>x</b>	<b>x</b>	<b>x</b>	
W	W	W	W	W	W	W	W	
x	x	x	x	x	x	x	x	

Figure 15-107. Abort GPIF

Write 0xFF to immediately abort a GPIF transaction and transition to the Idle State.

## 15.13 Endpoint Buffers

### 15.13.1 EP0 IN-OUT Buffer

EP0BUF		EP0 IN/OUT Buffer						E740-E77F	
b7	b6	b5	b4	b3	b2	b1	b0		
<b>D7</b>	<b>D6</b>	<b>D5</b>	<b>D4</b>	<b>D3</b>	<b>D2</b>	<b>D1</b>	<b>D0</b>		
R/W	R/W	R/W	R/W	R/W	R/W	R/W	R/W		
X	X	X	X	X	X	X	X		

Figure 15-108. EP0 IN/OUT Buffer

**Bit 7-0**                      **D7:0**    *EP0 Data*  
 EP0 Data buffer (IN/OUT). 64 bytes.

### 15.13.2 Endpoint 1-OUT Buffer

EP1OUTBUF		EP1-OUT Buffer						E780-E7BF	
b7	b6	b5	b4	b3	b2	b1	b0		
<b>D7</b>	<b>D6</b>	<b>D5</b>	<b>D4</b>	<b>D3</b>	<b>D2</b>	<b>D1</b>	<b>D0</b>		
R/W	R/W	R/W	R/W	R/W	R/W	R/W	R/W		
X	X	X	X	X	X	X	X		

Figure 15-109. EP1-OUT Buffer

**Bit 7-0**                      **D7:0**    *EP1-Out Data*  
 EP1-Out Data buffer. 64 bytes.

### 15.13.3 Endpoint 1-IN Buffer

**EP1INBUF** **EP1-IN Buffer** **E7C0-E7FF**

b7	b6	b5	b4	b3	b2	b1	b0
<b>D7</b>	<b>D6</b>	<b>D5</b>	<b>D4</b>	<b>D3</b>	<b>D2</b>	<b>D1</b>	<b>D0</b>
R/W	R/W	R/W	R/W	R/W	R/W	R/W	R/W
X	X	X	X	X	X	X	X

Figure 15-110. EP1-IN Buffer

**Bit 7-0** **D7:0** *EP1-IN Buffer*

EP1-IN Data buffer. 64 bytes.

### 15.13.4 Endpoint 2/Slave FIFO Buffer

**EP2FIFOBUF** **512/1024-byte EP2/Slave FIFO Buffer** **F000-F3FF**

b7	b6	b5	b4	b3	b2	b1	b0
<b>D7</b>	<b>D6</b>	<b>D5</b>	<b>D4</b>	<b>D3</b>	<b>D2</b>	<b>D1</b>	<b>D0</b>
R/W	R/W	R/W	R/W	R/W	R/W	R/W	R/W
X	X	X	X	X	X	X	X

Figure 15-111. 512/1024-byte EP2/Slave FIFO Buffer

**Bit 7-0** **D7:0** *EP2 Data*

512/1024-byte EP2 buffer.

### 15.13.5 512-byte Endpoint 4/Slave FIFO Buffer

EP4FIFOBUF		512-byte EP4/Slave FIFO Buffer				F400-F5FF	
b7	b6	b5	b4	b3	b2	b1	b0
<b>D7</b>	<b>D6</b>	<b>D5</b>	<b>D4</b>	<b>D3</b>	<b>D2</b>	<b>D1</b>	<b>D0</b>
R/W	R/W	R/W	R/W	R/W	R/W	R/W	R/W
X	X	X	X	X	X	X	X

Figure 15-112. 512-byte EP4/Slave FIFO Buffer

**Bit 7-0**                      **D7:0**    *EP4 Data*  
 512-byte EP4 buffer.

### 15.13.6 512/1024-byte Endpoint 6/Slave FIFO Buffer

EP6FIFOBUF		512/1024-byte EP6/Slave FIFO Buffer				F800-FBFF	
b7	b6	b5	b4	b3	b2	b1	b0
<b>D7</b>	<b>D6</b>	<b>D5</b>	<b>D4</b>	<b>D3</b>	<b>D2</b>	<b>D1</b>	<b>D0</b>
R/W	R/W	R/W	R/W	R/W	R/W	R/W	R/W
X	X	X	X	X	X	X	X

Figure 15-113. 512/1024-byte EP6/Slave FIFO Buffer

**Bit 7-0**                      **D7:0**    *EP6 Data*  
 512/1024-byte EP6 buffer.



### 15.13.7 512-byte Endpoint 8/Slave FIFO Buffer

#### EP8FIFOBUF      512-byte EP8/Slave FIFO Buffer      FC00-FDFF

b7	b6	b5	b4	b3	b2	b1	b0
<b>D7</b>	<b>D6</b>	<b>D5</b>	<b>D4</b>	<b>D3</b>	<b>D2</b>	<b>D1</b>	<b>D0</b>
R/W	R/W	R/W	R/W	R/W	R/W	R/W	R/W
X	X	X	X	X	X	X	X

Figure 15-114. 512-byte EP8/Slave FIFO Buffer

**Bit 7-0**                      **D7:0**    *EP8 Data*  
 512-byte EP8 buffer.

## 15.14 Synchronization Delay

Under certain conditions, some read and write accesses to FX2 registers must be separated by a *synchronization delay*. The delay is necessary only under the following conditions:

- Between a write to any register in the 0xE600-0xE6FF range and a write to one of the registers in Table 15-20.
- Between a write to one of the registers in Table 15-20 and a read from any register in the 0xE600-0xE6FF range.

Table 15-20. Registers Which Require a Synchronization Delay

FIFORESET	FIFOPINPOLAR
INPKTEND	EPxBCH:L
EPxFIFOPFH:L	EPxAUTOINLENH:L
EPxFIFOCFG	EPxGPIFFLGSEL
PINFLAG SAB	PINFLAGSCD
EPxFIFOIE	EPxFIFOIRQ
GPIFIE	GPIFIRQ
UDMACRCH:L	GPIFADRH:L
GPIFTRIG	EPxGPIFTRIG

The minimum delay length is a function of the IFCLK and CLKOUT (CPU Clock) frequencies, and is determined by the equation:

$$\text{Minimum Sync Delay, in CPU cycles} = \left\lceil 1.5 \times \left( \frac{\text{IFCLK Period}}{\text{CLKOUT Period}} + 1 \right) \right\rceil$$

Note:  
 $\lceil n \rceil$  means "round  $n$  upward"

The required delay length is smallest when the CPU is running at its slowest speed (12 MHz, 83.2 ns/cycle) and IFCLK is running at its fastest speed (48 MHz, 20.8 ns/cycle). Under those conditions, the minimum required delay is:

$$\left\lceil 1.5 \times \left( \frac{20.8}{83.2} + 1 \right) \right\rceil = \lceil 1.5 \times (1.25) \rceil = \lceil 1.875 \rceil = 2 \text{ CPU Cycles}$$

The longest delay is required when the CPU is running at its fastest speed (48MHz, 20.8 ns/cycle) and IFCLK is running much slower (e.g., 5.2 MHz, 192 ns/cycle):

$$\left\lceil 1.5 \times \left( \frac{192}{20.8} + 1 \right) \right\rceil = \lceil 1.5 \times (10.23) \rceil = \lceil 15.3 \rceil = 16 \text{ CPU Cycles}$$

The most-typical FX2 configuration, IFCLK and CLKOUT both running at 48 MHz, requires a minimum delay of:

$$\left\lceil 1.5 \times \left( \frac{20.8}{20.8} + 1 \right) \right\rceil = \lceil 1.5 \times (2) \rceil = \lceil 3 \rceil = 3 \text{ CPU Cycles}$$

## Appendix A

### Default Descriptors for Full Speed Mode

Tables A-1 through A-25 show the descriptor data built into the FX2 logic. The tables are presented in the order that the bytes are stored.

*Table A-1 Default USB Device Descriptor*

Offset	Field	Description	Value
0	bLength	Length of this Descriptor = 18 bytes	12H
1	bDescriptorType	Descriptor Type = <b>Device</b>	01H
2	bcdUSB (L)	USB Specification Version 2.00 (L)	00H
3	bcdUSB (H)	USB Specification Version 2.00 (H)	02H
4	bDeviceClass	Device Class (FF is Vendor-Specific)	FFH
5	bDeviceSubClass	Device Sub-class (FF is Vendor-Specific)	FFH
6	bDeviceProtocol	Device Protocol (FF is Vendor-Specific)	FFH
7	bMaxPacketSize0	Maximum Packet Size for EP0 = <b>64 bytes</b>	40H
8	idVendor (L)	Vendor ID (L) Cypress Semi = 04B4H	B4H
9	idVendor (H)	Vendor ID (H)	04H
10	idProduct (L)	Product ID (L) EZ-USB = 8613H	13H
11	idProduct (H)	Product ID (H)	86H
12	bcdDevice (L)	Device Release Number (BCD,L) (see individual data sheet)	xxH
13	bcdDevice (H)	Device Release Number (BCD,H) (see individual data sheet)	xxH
14	iManufacturer	Manufacturer Index String = None	00H
15	iProduct	Product Index String = None	00H
16	iSerialNumber	Serial number Index String = None	00H
17	bNumConfigurations	Number of Configurations in this Interface = 1	01H

The Device Descriptor specifies a MaxPacketSize of 64 bytes for endpoint 0, contains Cypress Semiconductor Vendor, Product and Release Number IDs, and uses no string indices. Release Number IDs (XX and YY) are found in individual Cypress Semiconductor data sheets. The FX2 logic returns this information response to a “Get\_Descriptor/Device” host request.

Table A-2 Device Qualifier

Offset	Field	Description	Value
0	bLength	Length of this Descriptor = 10 bytes	0AH
1	bDescriptorType	Descriptor Type = <b>Device Qualifier</b>	06H
2	bcdUSB (L)	USB Specification Version 2.00 (L)	00H
3	bcdUSB (H)	USB Specification Version 2.00 (H)	02H
4	bDeviceClass	Device Class (FF is Vendor-Specific)	FFH
5	bDeviceSubClass	Device Sub-class (FF is Vendor-Specific)	FFH
6	bDeviceProtocol	Device Protocol (FF is Vendor-Specific)	FFH
7	bMaxPacketSize0	Maximum Packet Size for other speed = <b>64 bytes</b>	40H
8	bNumConfigurations	Number of other Configurations = 1	01H
9	bReserved	Must be set to zero	00H

Table A-3 USB Default Configuration Descriptor

Offset	Field	Description	Value
0	bLength	Length of this Descriptor = 9 bytes	09H
1	bDescriptorType	Descriptor Type = <b>Configuration</b>	02H
2	wTotalLength (L)	Total Length (L) Including Interface and Endpoint Descriptors (171 total)	ABH
3	wTotalLength (H)	Total Length (H)	00H
4	bNumInterfaces	Number of Interfaces in this Configuration	01H
5	bConfigurationValue	Configuration Value Used by Set_Configuration Request to Select this interface	01H
6	iConfiguration	Index of String Describing this Configuration = None	00H
7	bmAttributes	Attributes - Bus-Powered, No Wakeup	80H
8	MaxPower	Maximum Power - 100 mA	32H

The configuration descriptor includes a total length field (offset 2-3) that encompasses all interface and endpoint descriptors that follow the configuration descriptor. This configuration describes a single interface (offset 4). The host selects this configuration by issuing a Set\_Configuration requests specifying configuration #1 (offset 5).

Table A-4 USB Default Interface 0, Alternate Setting 0

Offset	Field	Description	Value
0	bLength	Length of the Interface Descriptor	09H
1	bDescriptorType	Descriptor Type = <b>Interface</b>	04H
2	bInterfaceNumber	Zero based index of this interface = <b>0</b>	00H
3	bAlternateSetting	Alternate Setting Value = <b>0</b>	00H
4	bNumEndpoints	Number of endpoints in this interface (not counting EP0) = <b>0</b>	00H
5	bInterfaceClass	Interface Class = Vendor Specific	FFH
6	bInterfaceSubClass	Interface Sub-class = Vendor Specific	FFH
7	bInterfaceProtocol	Interface Protocol = Vendor Specific	FFH
8	iInterface	Index to string descriptor for this interface = None	00H

Table A-5 USB Default Interface 0, Alternate Setting 1

Offset	Field	Description	Value
0	bLength	Length of this Interface Descriptor	09H
1	bDescriptorType	Descriptor Type = <b>Interface</b>	04H
2	bInterfaceNumber	Zero based index of this interface = <b>0</b>	00H
3	bAlternateSetting	Alternate Setting Value = <b>1</b>	01H
4	bNumEndpoints	Number of endpoints in this interface (not counting EP0) = <b>6</b>	06H
5	bInterfaceClass	Interface Class = Vendor Specific	FFH
6	bInterfaceSubClass	Interface Sub-class = Vendor Specific	FFH
7	bInterfaceProtocol	Interface Protocol = Vendor Specific	FFH
8	iInterface	Index to string descriptor for this interface = None	00H

Table A-6 Endpoint Descriptor (EP1 out)

Offset	Field	Description	Value
0	bLength	Length of this Endpoint Descriptor	07H
1	bDescriptorType	Descriptor Type = <b>Endpoint</b>	05H
2	bEndpointAddress	Endpoint direction (1 is in) and address = <b>OUT1</b>	01H
3	bmAttributes	XFR Type = <b>BULK</b>	02H
4	wMaxPacketSize (L)	Maximum Packet Size = <b>64 bytes</b>	40H
5	WMaxPacketSize (H)	Maximum Packet Size - High	00H
6	bInterval	Polling Interval in Milliseconds ( <b>1 for iso</b> )	00H

Table A-7 Endpoint Descriptor (EP1 in)

Offset	Field	Description	Value
0	bLength	Length of this Endpoint Descriptor	07H
1	bDescriptorType	Descriptor Type = <b>Endpoint</b>	05H
2	bEndpointAddress	Endpoint Direction (1 is in) and address = <b>IN1</b>	81H
3	bmAttributes	XFR Type = <b>BULK</b>	02H
4	wMaxPacketSize (L)	Maximum Packet Size = 64 bytes	40H
5	WMaxPacketSize (H)	Maximum Packet Size - High	00H
6	bInterval	Polling Interval in Milliseconds (1 for iso)	00H

Table A-8 Endpoint Descriptor (EP2)

Offset	Field	Description	Value
0	bLength	Length of this Endpoint Descriptor	07H
1	bDescriptorType	Descriptor Type = <b>Endpoint</b>	05H
2	bEndpointAddress	Endpoint Direction (1 is in) and address = <b>OUT2</b>	02H
3	bmAttributes	XFR Type = BULK	02H
4	wMaxPacketSize (L)	Maximum Packet Size = 64 bytes	40H
5	WMaxPacketSize (H)	Maximum Packet Size - High	00H
6	bInterval	Polling Interval in Milliseconds (1 for iso)	00H

Table A-9 Endpoint Descriptor (EP4)

Offset	Field	Description	Value
0	bLength	Length of this Endpoint Descriptor	07H
1	bDescriptorType	Descriptor Type = <b>Endpoint</b>	05H
2	bEndpointAddress	Endpoint Direction (1 is in) and address = <b>OUT4</b>	04H
3	bmAttributes	XFR Type = BULK	02H
4	wMaxPacketSize (L)	Maximum Packet Size = 64 bytes	40H
5	WMaxPacketSize (H)	Maximum Packet Size - High	00H
6	bInterval	Polling Interval in Milliseconds (1 for iso)	00H

Table A-10 Endpoint Descriptor (EP6)

Offset	Field	Description	Value
0	bLength	Length of this Endpoint Descriptor	07H
1	bDescriptorType	Descriptor Type = <b>Endpoint</b>	05H
2	bEndpointAddress	Endpoint Direction (1 is in) and address = IN6	86H
3	bmAttributes	XFR Type = BULK	02H
4	wMaxPacketSize (L)	Maximum Packet Size = 64 bytes	40H
5	WMaxPacketSize (H)	Maximum Packet Size - High	00H
6	bInterval	Polling Interval in Milliseconds (1 for iso)	00H

Table A-11 Endpoint Descriptor (EP8)

Offset	Field	Description	Value
0	bLength	Length of this Endpoint Descriptor	07H
1	bDescriptorType	Descriptor Type = <b>Endpoint</b>	05H
2	bEndpointAddress	Endpoint Direction (1 is in) and address = IN8	88H
3	bmAttributes	XFR Type = BULK	02H
4	wMaxPacketSize (L)	Maximum Packet Size = 64 bytes	40H
5	WMaxPacketSize (H)	Maximum Packet Size - High	00H
6	bInterval	Polling Interval in Milliseconds (1 for iso)	00H

Table A-12 Interface Descriptor (Alt. Setting 2)

Offset	Field	Description	Value
0	bLength	Length of the Interface Descriptor	09H
1	bDescriptorType	Descriptor Type = <b>Interface</b>	04H
2	bInterfaceNumber	Zero based index of this interface = 0	00H
3	bAlternateSetting	Alternate Setting Value = 2	02H
4	bNumEndpoints	Number of endpoints in this interface (not counting EP0) = 6	06H
5	bInterfaceClass	Interface Class = Vendor Specific	FFH
6	bInterfaceSubClass	Interface Sub-class = Vendor Specific	FFH
7	bInterfaceProtocol	Interface Protocol = Vendor Specific	FFH
8	iInterface	Index to string descriptor for this interface = None	00H

Table A-13 Endpoint Descriptor (EP1 out)

Offset	Field	Description	Value
0	bLength	Length of this Endpoint Descriptor	07H
1	bDescriptorType	Descriptor Type = <b>Endpoint</b>	05H
2	bEndpointAddress	Endpoint Direction (1 is in) and address = OUT1	01H
3	bmAttributes	XFR Type = INT	03H
4	wMaxPacketSize (L)	Maximum Packet Size = 64 bytes	40H
5	WMaxPacketSize (H)	Maximum Packet Size - High	00H
6	bInterval	Polling Interval in Milliseconds (1 for iso)	0AH

Table A-14 Endpoint Descriptor (EP1 in)

Offset	Field	Description	Value
0	bLength	Length of this Endpoint Descriptor	07H
1	bDescriptorType	Descriptor Type = <b>Endpoint</b>	05H
2	bEndpointAddress	Endpoint Direction (1 is in) and address = IN1	81H
3	bmAttributes	XFR Type = INT	03H
4	wMaxPacketSize (L)	Maximum Packet Size = 64 bytes	40H
5	WMaxPacketSize (H)	Maximum Packet Size - High	00H
6	bInterval	Polling Interval in Milliseconds (1 for iso)	0AH

Table A-15 Endpoint Descriptor (EP2)

Offset	Field	Description	Value
0	bLength	Length of this Endpoint Descriptor	07H
1	bDescriptorType	Descriptor Type = <b>Endpoint</b>	05H
2	bEndpointAddress	Endpoint Direction (1 is in) and address = OUT2	02H
3	bmAttributes	XFR Type = INT	03H
4	wMaxPacketSize (L)	Maximum Packet Size = 64 bytes	40H
5	WMaxPacketSize (H)	Maximum Packet Size - High	00H
6	bInterval	Polling Interval in Milliseconds (1 for iso)	0AH



Table A-16 Endpoint Descriptor (EP4)

Offset	Field	Description	Value
0	bLength	Length of this Endpoint Descriptor	07H
1	bDescriptorType	Descriptor Type = <b>Endpoint</b>	05H
2	bEndpointAddress	Endpoint Direction (1 is in) and address = OUT4	04H
3	bmAttributes	XFR Type = BULK	02H
4	wMaxPacketSize (L)	Maximum Packet Size = 64 bytes	40H
5	WMaxPacketSize (H)	Maximum Packet Size - High	00H
6	bInterval	Polling Interval in Milliseconds (1 for iso)	00H

Table A-17 Endpoint Descriptor (EP6)

Offset	Field	Description	Value
0	bLength	Length of this Endpoint Descriptor	07H
1	bDescriptorType	Descriptor Type = <b>Endpoint</b>	05H
2	bEndpointAddress	Endpoint Direction (1 is in) and address = IN6	86H
3	bmAttributes	XFR Type = INT	03H
4	wMaxPacketSize (L)	Maximum Packet Size = 64 bytes	40H
5	WMaxPacketSize (H)	Maximum Packet Size - High	00H
6	bInterval	Polling Interval in Milliseconds (1 for iso)	0AH

Table A-18 Endpoint Descriptor (EP8)

Offset	Field	Description	Value
0	bLength	Length of this Endpoint Descriptor	07H
1	bDescriptorType	Descriptor Type = <b>Endpoint</b>	05H
2	bEndpointAddress	Endpoint Direction (1 is in) and address = IN8	88H
3	bmAttributes	XFR Type = BULK	02H
4	wMaxPacketSize (L)	Maximum Packet Size = 64 bytes	40H
5	WMaxPacketSize (H)	Maximum Packet Size - High	00H
6	bInterval	Polling Interval in Milliseconds (1 for iso)	00H

Table A-19 Interface Descriptor (Alt. Setting 3)

Offset	Field	Description	Value
0	bLength	Length of the Interface Descriptor	09H
1	bDescriptorType	Descriptor Type = <b>Interface</b>	04H
2	bInterfaceNumber	Zero based index of this interface = 0	00H
3	bAlternateSetting	Alternate Setting Value = 3	03H
4	bNumEndpoints	Number of endpoints in this interface (not counting EP0) = 6	06H
5	bInterfaceClass	Interface Class = Vendor Specific	FFH
6	bInterfaceSubClass	Interface Sub-class = Vendor Specific	FFH
7	bInterfaceProtocol	Interface Protocol = Vendor Specific	FFH
8	iInterface	Index to string descriptor for this interface = None	00H

Table A-20 Endpoint Descriptor (EP1 out)

Offset	Field	Description	Value
0	bLength	Length of this Endpoint Descriptor	07H
1	bDescriptorType	Descriptor Type = <b>Endpoint</b>	05H
2	bEndpointAddress	Endpoint Direction (1 is in) and address = OUT1	01H
3	bmAttributes	XFR Type = INT	03H
4	wMaxPacketSize (L)	Maximum Packet Size = 64 bytes	40H
5	WMaxPacketSize (H)	Maximum Packet Size - High	00H
6	bInterval	Polling Interval in Milliseconds (1 for iso)	0AH

Table A-21 Endpoint Descriptor (EP1 in)

Offset	Field	Description	Value
0	bLength	Length of this Endpoint Descriptor	07H
1	bDescriptorType	Descriptor Type = <b>Endpoint</b>	05H
2	bEndpointAddress	Endpoint Direction (1 is in) and address = IN1	81H
3	bmAttributes	XFR Type = INT	03H
4	wMaxPacketSize (L)	Maximum Packet Size = 64 bytes	40H
5	WMaxPacketSize (H)	Maximum Packet Size - High	00H
6	bInterval	Polling Interval in Milliseconds (1 for iso)	0AH

Table A-22 Endpoint Descriptor (EP2)

Offset	Field	Description	Value
0	bLength	Length of this Endpoint Descriptor	07H
1	bDescriptorType	Descriptor Type = <b>Endpoint</b>	05H
2	bEndpointAddress	Endpoint Direction (1 is in) and address = OUT2	02H
3	bmAttributes	XFR Type = ISO, No Synchronization, Data endpoint	01H
4	wMaxPacketSize (L)	Maximum Packet Size = 64 bytes	40H
5	WMaxPacketSize (H)	Maximum Packet Size - High	00H
6	bInterval	Polling Interval in Milliseconds (1 for iso)	01H

Table A-23 Endpoint Descriptor (EP4)

Offset	Field	Description	Value
0	bLength	Length of this Endpoint Descriptor	07H
1	bDescriptorType	Descriptor Type = <b>Endpoint</b>	05H
2	bEndpointAddress	Endpoint Direction (1 is in) and address = OUT4	04H
3	bmAttributes	XFR Type = BULK	02H
4	wMaxPacketSize (L)	Maximum Packet Size = 64 bytes	40H
5	WMaxPacketSize (H)	Maximum Packet Size - High	00H
6	bInterval	Polling Interval in Milliseconds (1 for iso)	00H

Table A-24 Endpoint Descriptor (EP6)

Offset	Field	Description	Value
0	bLength	Length of this Endpoint Descriptor	07H
1	bDescriptorType	Descriptor Type = <b>Endpoint</b>	05H
2	bEndpointAddress	Endpoint Direction (1 is in) and address = IN6	86H
3	bmAttributes	XFR Type = ISO, No Synchronization, Data Endpoint	01H
4	wMaxPacketSize (L)	Maximum Packet Size = 64 bytes	40H
5	WMaxPacketSize (H)	Maximum Packet Size - High	00H
6	bInterval	Polling Interval in Milliseconds (1 for iso)	01H

Table A-25 Endpoint Descriptor (EP8)

Offset	Field	Description	Value
0	bLength	Length of this Endpoint Descriptor	07H
1	bDescriptorType	Descriptor Type = <b>Endpoint</b>	05H
2	bEndpointAddress	Endpoint Direction (1 is in) and address = IN8	88H
3	bmAttributes	XFR Type = BULK	02H
4	wMaxPacketSize (L)	Maximum Packet Size = 64 bytes	40H
5	WMaxPacketSize (H)	Maximum Packet Size - High	00H
6	bInterval	Polling Interval in Milliseconds (1 for iso)	00H

## Appendix B

### Default Descriptors for High Speed Mode

Tables B-1 through B-25 show the descriptor data built into the FX2 logic. The tables are presented in the order that the bytes are stored.

*Table B-1 Device Descriptor*

Offset	Field	Description	Value
0	bLength	Length of this Descriptor = 18 bytes	12H
1	bDescriptorType	Descriptor Type = <b>Device</b>	01H
2	bcdUSB (L)	USB Specification Version 2.00 (L)	00H
3	bcdUSB (H)	USB Specification Version 2.00 (H)	02H
4	bDeviceClass	Device Class (FF is Vendor-Specific)	FFH
5	bDeviceSubClass	Device Sub-class (FF is Vendor-Specific)	FFH
6	bDeviceProtocol	Device Protocol (FF is Vendor-Specific)	FFH
7	bMaxPacketSize0	Maximum Packet Size for EP0 = <b>64 bytes</b>	40H
8	idVendor (L)	Vendor ID (L) Cypress Semi = 04B4H	B4H
9	idVendor (H)	Vendor ID (H)	04H
10	idProduct (L)	Product ID (L) EZ-USB = 8613H	13H
11	idProduct (H)	Product ID (H)	86H
12	bcdDevice (L)	Device Release Number (BCD,L) (see individual data sheet)	xxH
13	bcdDevice (H)	Device Release Number (BCD,H) (see individual data sheet)	xxH
14	iManufacturer	Manufacturer Index String = None	00H
15	iProduct	Product Index String = None	00H
16	iSerialNumber	Serial Number Index String = None	00H
17	bNumConfigurations	Number of Configurations in this Interface = 1	01H

The Device Descriptor specifies a MaxPacketSize of 64 bytes for endpoint 0, contains Cypress Semiconductor Vendor, Product and Release Number IDs, and uses no string indices. Release Number IDs (XX and YY) are found in individual Cypress Semiconductor data sheets. The FX2 logic returns this information response to a “Get\_Descriptor/Device” host request.

Table B-2 Device Qualifier

Offset	Field	Description	Value
0	bLength	Length of this Descriptor = 10 bytes	0AH
1	bDescriptorType	Descriptor Type = <b>Device Qualifier</b>	06H
2	bcdUSB (L)	USB Specification Version 2.00 (L)	00H
3	bcdUSB (H)	USB Specification Version 2.00 (H)	02H
4	bDeviceClass	Device Class (FF is vendor-specific)	FFH
5	bDeviceSubClass	Device Sub-class (FF is vendor-specific)	FFH
6	bDeviceProtocol	Device Protocol (FF is vendor-specific)	FFH
7	bMaxPacketSize0	Maximum Packet Size for other speed = 64 bytes	40H
8	bNumConfigurations	Number of other Configurations = 1	01H
9	bReserved	Must be set to Zero	00H

Table B-3 Configuration Descriptor

Offset	Field	Description	Value
0	bLength	Length of this Descriptor = 9 bytes	09H
1	bDescriptorType	Descriptor Type = <b>Configuration</b>	02H
2	wTotalLength (L)	Total length (L) including Interface and Endpoint descriptors (171 total)	ABH
3	wTotalLength (H)	Total Length (H)	00H
4	bNumInterfaces	Number of Interfaces in this Configuration	01H
5	bConfigurationValue	Configuration value used by Set_Configuration Request to select this interface	01H
6	iConfiguration	Index of String Describing this Configuration = None	00H
7	bmAttributes	Attributes - Bus Powered, No Wakeup	80H
8	MaxPower	Maximum Power - 100 ma	32H

*Table B-4 Interface Descriptor (Alt. Setting 0)*

Offset	Field	Description	Value
0	bLength	Length of the Interface Descriptor	09H
1	bDescriptorType	Descriptor Type = <b>Interface</b>	04H
2	bInterfaceNumber	Zero based index of this interface = 0	00H
3	bAlternateSetting	Alternate Setting Value = 0	00H
4	bNumEndpoints	Number of endpoints in this interface (not counting EP0) = 0	00H
5	bInterfaceClass	Interface Class = Vendor Specific	FFH
6	bInterfaceSubClass	Interface Sub-class = Vendor Specific	FFH
7	bInterfaceProtocol	Interface Protocol = Vendor Specific	FFH
8	iInterface	Index to string descriptor for this interface = None	00H

*Table B-5 Interface Descriptor (Alt. Setting 1)*

Offset	Field	Description	Value
0	bLength	Length of the Interface Descriptor	09H
1	bDescriptorType	Descriptor Type = <b>Interface</b>	04H
2	bInterfaceNumber	Zero based index of this interface = 0	00H
3	bAlternateSetting	Alternate Setting Value = 1	01H
4	bNumEndpoints	Number of endpoints in this interface (not counting EP0) = 6	06H
5	bInterfaceClass	Interface Class = Vendor Specific	FFH
6	bInterfaceSubClass	Interface Sub-class = Vendor Specific	FFH
7	bInterfaceProtocol	Interface Protocol = Vendor Specific	FFH
8	iInterface	Index to string descriptor for this interface = None	00H

*Table B-6 Endpoint Descriptor (EP1 out)*

Offset	Field	Description	Value
0	bLength	Length of this Endpoint Descriptor	07H
1	bDescriptorType	Descriptor Type = <b>Endpoint</b>	05H
2	bEndpointAddress	Endpoint Direction (1 is in) and address = OUT1	01H
3	bmAttributes	XFR Type = BULK	02H
4	wMaxPacketSize (L)	Maximum Packet Size = 512 bytes	00H
5	WMaxPacketSize (H)	Maximum Packet Size - High	02H
6	bInterval	Polling Interval in Milliseconds (1 for iso)	00H

Table B-7 Endpoint Descriptor (EP1 in)

Offset	Field	Description	Value
0	bLength	Length of this Endpoint Descriptor	07H
1	bDescriptorType	Descriptor Type = <b>Endpoint</b>	05H
2	bEndpointAddress	Endpoint Direction (1 is in) and address = IN1	81H
3	bmAttributes	XFR Type = BULK	02H
4	wMaxPacketSize (L)	Maximum Packet Size = 512 bytes	00H
5	WMaxPacketSize (H)	Maximum Packet Size - High	02H
6	bInterval	Polling Interval in Milliseconds (1 for iso)	00H

Table B-8 Endpoint Descriptor (EP2)

Offset	Field	Description	Value
0	bLength	Length of this Endpoint Descriptor	07H
1	bDescriptorType	Descriptor Type = <b>Endpoint</b>	05H
2	bEndpointAddress	Endpoint Direction (1 is in) and address = OUT2	02H
3	bmAttributes	XFR Type = BULK	02H
4	wMaxPacketSize (L)	Maximum Packet Size = 512 bytes	00H
5	WMaxPacketSize (H)	Maximum Packet Size - High	02H
6	bInterval	Polling Interval in Milliseconds (1 for iso)	00H

Table B-9 Endpoint Descriptor (EP4)

Offset	Field	Description	Value
0	bLength	Length of this Endpoint Descriptor	07H
1	bDescriptorType	Descriptor Type = <b>Endpoint</b>	05H
2	bEndpointAddress	Endpoint Direction (1 is in) and address = OUT4	04H
3	bmAttributes	XFR Type = BULK	02H
4	wMaxPacketSize (L)	Maximum Packet Size = 512 bytes	00H
5	WMaxPacketSize (H)	Maximum Packet Size - High	02H
6	bInterval	Polling Interval in Milliseconds (1 for iso)	00H



Table B-10 Endpoint Descriptor (EP6)

Offset	Field	Description	Value
0	bLength	Length of this Endpoint Descriptor	07H
1	bDescriptorType	Descriptor Type = <b>Endpoint</b>	05H
2	bEndpointAddress	Endpoint Direction (1 is in) and address = IN6	86H
3	bmAttributes	XFR Type = BULK	02H
4	wMaxPacketSize (L)	Maximum Packet Size = 512 bytes	00H
5	WMaxPacketSize (H)	Maximum Packet Size - High	02H
6	bInterval	Polling Interval in Milliseconds (1 for iso)	00H

Table B-11 Endpoint Descriptor (EP8)

Offset	Field	Description	Value
0	bLength	Length of this Endpoint Descriptor	07H
1	bDescriptorType	Descriptor Type = <b>Endpoint</b>	05H
2	bEndpointAddress	Endpoint Direction (1 is in) and address = IN8	88H
3	bmAttributes	XFR Type = BULK	02H
4	wMaxPacketSize (L)	Maximum Packet Size = 512 bytes	00H
5	WMaxPacketSize (H)	Maximum Packet Size - High	02H
6	bInterval	Polling Interval in Milliseconds (1 for iso)	00H

Table B-12 Interface Descriptor (Alt. Setting 2)

Offset	Field	Description	Value
0	bLength	Length of the Interface Descriptor	09H
1	bDescriptorType	Descriptor Type = <b>Interface</b>	04H
2	bInterfaceNumber	Zero based index of this interface = 0	00H
3	bAlternateSetting	Alternate Setting Value = 2	02H
4	bNumEndpoints	Number of endpoints in this interface (not counting EP0) = 6	06H
5	bInterfaceClass	Interface Class = Vendor Specific	FFH
6	bInterfaceSubClass	Interface Sub-class = Vendor Specific	FFH
7	bInterfaceProtocol	Interface Protocol = Vendor Specific	FFH
8	iInterface	Index to string descriptor for this interface = None	00H

Table B-13 Endpoint Descriptor (EP1 out)

Offset	Field	Description	Value
0	bLength	Length of this Endpoint Descriptor	07H
1	bDescriptorType	Descriptor Type = <b>Endpoint</b>	05H
2	bEndpointAddress	Endpoint Direction (1 is in) and address = OUT1	01H
3	bmAttributes	XFR Type = INT	03H
4	wMaxPacketSize (L)	Maximum Packet Size = 64 bytes	40H
5	WMaxPacketSize (H)	Maximum Packet Size - High	00H
6	bInterval	Polling Interval in Milliseconds (1 for iso)	01H

Table B-14 Endpoint Descriptor (EP1 in)

Offset	Field	Description	Value
0	bLength	Length of this Endpoint Descriptor	07H
1	bDescriptorType	Descriptor Type = <b>Endpoint</b>	05H
2	bEndpointAddress	Endpoint Direction (1 is in) and address = IN1	81H
3	bmAttributes	XFR Type = INT	03H
4	wMaxPacketSize (L)	Maximum Packet Size = 64 bytes	40H
5	WMaxPacketSize (H)	Maximum Packet Size - High	00H
6	bInterval	Polling Interval in Milliseconds (1 for iso)	01H

Table B-15 Endpoint Descriptor (EP2)

Offset	Field	Description	Value
0	bLength	Length of this Endpoint Descriptor	07H
1	bDescriptorType	Descriptor Type = <b>Endpoint</b>	05H
2	bEndpointAddress	Endpoint Direction (1 is in) and address = OUT2	02H
3	bmAttributes	XFR Type = INT	03H
4	wMaxPacketSize (L)	Maximum Packet Size = 512 bytes	00H
5	WMaxPacketSize (H)	Maximum Packet Size - High	02H
6	bInterval	Polling Interval in Milliseconds (1 for iso)	01H

*Table B-16 Endpoint Descriptor (EP4)*

Offset	Field	Description	Value
0	bLength	Length of this Endpoint Descriptor	07H
1	bDescriptorType	Descriptor Type = <b>Endpoint</b>	05H
2	bEndpointAddress	Endpoint Direction (1 is in) and address = OUT4	04H
3	bmAttributes	XFR Type = BULK	02H
4	wMaxPacketSize (L)	Maximum Packet Size = 512 bytes	00H
5	WMaxPacketSize (H)	Maximum Packet Size - High	02H
6	bInterval	Polling Interval in Milliseconds (1 for iso)	00H

*Table B-17 Endpoint Descriptor (EP6)*

Offset	Field	Description	Value
0	bLength	Length of this Endpoint Descriptor	07H
1	bDescriptorType	Descriptor Type = <b>Endpoint</b>	05H
2	bEndpointAddress	Endpoint Direction (1 is in) and address = IN6	86H
3	bmAttributes	XFR Type = INT	03H
4	wMaxPacketSize (L)	Maximum Packet Size = 512 bytes	00H
5	WMaxPacketSize (H)	Maximum Packet Size - High	02H
6	bInterval	Polling Interval in Milliseconds (1 for iso)	01H

*Table B-18 Endpoint Descriptor (EP8)*

Offset	Field	Description	Value
0	bLength	Length of this Endpoint Descriptor	07H
1	bDescriptorType	Descriptor Type = <b>Endpoint</b>	05H
2	bEndpointAddress	Endpoint Direction (1 is in) and address = IN8	88H
3	bmAttributes	XFR Type = BULK	02H
4	wMaxPacketSize (L)	Maximum Packet Size = 512 bytes	00H
5	WMaxPacketSize (H)	Maximum Packet Size - High	02H
6	bInterval	Polling Interval in Milliseconds (1 for iso)	00H

Table B-19 Interface Descriptor (Alt. Setting 3)

Offset	Field	Description	Value
0	bLength	Length of the Interface Descriptor	09H
1	bDescriptorType	Descriptor Type = <b>Interface</b>	04H
2	bInterfaceNumber	Zero based index of this interface = 0	00H
3	bAlternateSetting	Alternate Setting Value = 3	03H
4	bNumEndpoints	Number of endpoints in this interface (not counting EP0) = 6	06H
5	bInterfaceClass	Interface Class = Vendor Specific	FFH
6	bInterfaceSubClass	Interface Sub-class = Vendor Specific	FFH
7	bInterfaceProtocol	Interface Protocol = Vendor Specific	FFH
8	iInterface	Index to string descriptor for this interface = None	00H

Table B-20 Endpoint Descriptor (EP1 out)

Offset	Field	Description	Value
0	bLength	Length of this Endpoint Descriptor	07H
1	bDescriptorType	Descriptor Type = <b>Endpoint</b>	05H
2	bEndpointAddress	Endpoint Direction (1 is in) and address = OUT1	01H
3	bmAttributes	XFR Type = INT	03H
4	wMaxPacketSize (L)	Maximum Packet Size = 64 bytes	40H
5	WMaxPacketSize (H)	Maximum Packet Size - High	00H
6	bInterval	Polling Interval in Milliseconds (1 for iso)	01H

Table B-21 Endpoint Descriptor (EP1 in)

Offset	Field	Description	Value
0	bLength	Length of this Endpoint Descriptor	07H
1	bDescriptorType	Descriptor Type = <b>Endpoint</b>	05H
2	bEndpointAddress	Endpoint Direction (1 is in) and address = IN1	81H
3	bmAttributes	XFR Type = INT	03H
4	wMaxPacketSize (L)	Maximum Packet Size = 64 bytes	40H
5	WMaxPacketSize (H)	Maximum Packet Size - High	00H
6	bInterval	Polling Interval in Milliseconds (1 for iso)	01H

Table B-22 Endpoint Descriptor (EP2)

Offset	Field	Description	Value
0	bLength	Length of this Endpoint Descriptor	07H
1	bDescriptorType	Descriptor Type = <b>Endpoint</b>	05H
2	bEndpointAddress	Endpoint Direction (1 is in) and address = OUT2	02H
3	bmAttributes	XFR Type = ISO, No Synchronization, Data endpoint	01H
4	wMaxPacketSize (L)	Maximum Packet Size = 512 bytes	00H
5	WMaxPacketSize (H)	Maximum Packet Size - High	02H
6	bInterval	Polling Interval in Milliseconds (1 for iso)	01H

Table B-23 Endpoint Descriptor (EP4)

Offset	Field	Description	Value
0	bLength	Length of this Endpoint Descriptor	07H
1	bDescriptorType	Descriptor Type = <b>Endpoint</b>	05H
2	bEndpointAddress	Endpoint Direction (1 is in) and address = OUT4	04H
3	bmAttributes	XFR Type = BULK	02H
4	wMaxPacketSize (L)	Maximum Packet Size = 512 bytes	00H
5	WMaxPacketSize (H)	Maximum Packet Size - High	02H
6	bInterval	Polling Interval in Milliseconds (1 for iso)	00H

Table B-24 Endpoint Descriptor (EP6)

Offset	Field	Description	Value
0	bLength	Length of this Endpoint Descriptor	07H
1	bDescriptorType	Descriptor Type = <b>Endpoint</b>	05H
2	bEndpointAddress	Endpoint Direction (1 is in) and address = IN6	86H
3	bmAttributes	XFR Type = ISO, No Synchronization, Data endpoint	01H
4	wMaxPacketSize (L)	Maximum Packet Size = 512 bytes	00H
5	WMaxPacketSize (H)	Maximum Packet Size - High	02H
6	bInterval	Polling Interval in Milliseconds (1 for iso)	01H

Table B-25 Endpoint Descriptor (EP8)

Offset	Field	Description	Value
0	bLength	Length of this Endpoint Descriptor	07H
1	bDescriptorType	Descriptor Type = <b>Endpoint</b>	05H
2	bEndpointAddress	Endpoint Direction (1 is in) and address = IN8	88H
3	bmAttributes	XFR Type = BULK	02H
4	wMaxPacketSize (L)	Maximum Packet Size = 512 bytes	00H
5	WMaxPacketSize (H)	Maximum Packet Size - High	02H
6	bInterval	Polling Interval in Milliseconds (1 for iso)	00H

## Appendix C

### FX2 Register Summary

The following table is a summary of all the EZ-USB FX2 Registers.

In the “b7-b0” columns, bit positions that contain a 0 or a 1 cannot be written to and, when read, always return the value shown (0 or 1). Bit positions that contain “-” are available but unused.

The “Default” column shows each register’s power-on-reset value (“x” indicates “undefined”).

The “Access” column indicates each register’s read/write accessibility.







## EZ-USB FX2 Registers & Buffers

### Register Summary

Hex	Size	Name	Description	b7	b6	b5	b4	b3	b2	b1	b0	Default	Access	Notes
<b>GPIF Waveform Memories</b>														
E400	128	WAVEDATA	GPIF Waveform Descriptor 0, 1, 2, 3 data	D7	D6	D5	D4	D3	D2	D1	D0	xxxxxxx	RW	associated / pointed to by GPIWFSELECT
E480	384	reserved												
<b>GENERAL CONFIGURATION</b>														
E600	1	CPUCS	CPU Control & Status	0	0	PORTCSTB	CLKSPD1	CLKSPD0	CLKINV	CLKOE	8051RES	00010011	rrrrrr	<b>PORTCSTB</b> =1: reads/writes to PORTC generate RD# and WR# strobes <b>CLKSPD1:0</b> =8051 clock speed: 00=12, 01=24, 10=48, 11=X <b>CLKINV</b> =1 to invert CLKOUT signal <b>CLKOE</b> =1 to drive CLKOUT pin <b>8051RES</b> =1 to reset 8051
E601	1	IFCONFIG	Interface Configuration (Ports, GPIF, slave FIFOs)	IFCLKSRC	3048MHZ	IFCLKOE	IFCLKPOL	ASYNC	GSTATE	IFCFG1	IFCFG0	11000000	RW	<b>IFCLKSRC</b> : FIFO/GPIF Clock Source: 0:external (FGCLK pin); 1:internal <b>3048MHZ</b> : Internal FIFO/GPIF clock freq: 0=30 MHz, 1=48 MHz <b>IFCLKOE</b> : FIFO/GPIF Clock Output Enable (on IFCLK pin) <b>IFCLKPOL</b> : FIFO/GPIF output clock polarity (on IFCLK pin) <b>ASYNC</b> : 1=FIFOs/GPIF use internal clock (30/48); 0=use external IFCLK <b>GSTATE</b> : 1: drive GSTATE[0:2] on PORTE[0:2] <b>IFCFG[1:0]</b> : 00: ports; 01: reserved; 10: GPIF; 11: Slave FIFO (ext master)
E602	1	PINFLAGSAB <i>see Section 15.14</i>	Slave FIFO FLAGA and FLAGB Pin Configuration	FLAGB3	FLAGB2	FLAGB1	FLAGB0	FLAGA3	FLAGA2	FLAGA1	FLAGA0	00000000	RW	<b>FLAGx[3:0]</b> where x=A,B,C or D FIFO Flag:
E603	1	PINFLAGSCD <i>see Section 15.14</i>	Slave FIFO FLAGC and FLAGD Pin Configuration	FLAGD3	FLAGD2	FLAGD1	FLAGD0	FLAGC3	FLAGC2	FLAGC1	FLAGC0	01000000	RW	0000: PF for FIFO selected by FIFOADR[1:0] pins. 0001-0011: reserved 0100: EP2 PF, 0101: EP4PF, 0110: EP6PF, 0111: EP8 PF 1000: EP2 EF, 1001: EP4EF, 1010: EP6EF, 1011: EP8 EF 1100: EP2 FF, 1101: EP4FF, 1110: EP6FF, 1111: EP8FF
E604	1	FIFORESET <i>see Section 15.14</i>	Restore FIFOS to default state	NAKALL	x	x	x	x	x	x	x	xxxxxxx	W	Set flags and byte counts to default values; write 0x80 to NAK all transfers, then write FIFO number, then write 0x00 to restore normal operation
E605	1	BREAKPT	Breakpoint Control	0	0	0	0	BREAK	BPPULSE	BPEN	0	00000000	rrrrbbr	
E606	1	BPADDRH	Breakpoint Address H	A15	A14	A13	A12	A11	A10	A9	A8	xxxxxxx	RW	
E607	1	BPADDRL	Breakpoint Address L	A7	A6	A5	A4	A3	A2	A1	A0	xxxxxxx	RW	



## EZ-USB FX2 Registers & Buffers

Hex	Size	Name	Description	b7	b6	b5	b4	b3	b2	b1	b0	Default	Access	Notes
E608	1	UART230	230 Kbaud internally generated ref. clock	0	0	0	0	0	0	230UART1	230UART0	00000000	rrrrrb	If "1", overrides timer inputs to UART. 230 rate valid for any CPU clock rate.
E609	1	FIFOPINPOLAR <i>see Section 15.14</i>	slave FIFO Interface pins polarity	0	0	PKTEND	SLOE	SLRD	SLWR	EF	FF	00000000	rrbbbb	0=active low, 1=active high
E60A	1	REVID	Chip Revision	rv7	rv6	rv5	rv4	rv3	rv2	rv1	rv0	See Datasheet	R	Chip revision number
	1	reserved												
		<b>UDMA</b>												
E60C	1	GPIFHOLDTIME	MSTB Hold Time (for UDMA)	0	0	0	0	0	0	HOLDTIME1	HOLDTIME0	00000000	rrrrrb	
	3	reserved												
		<b>ENDPOINT CONFIGURATION</b>												
														<b>TYPE[00]</b> = illegal; 01=ISO, 10=BULK, 11=INT. <b>dir</b> =0:OUT, dir=1:IN <b>BUF1:0</b> : 00=quad, 01=illegal, 10=double, 11=triple <b>SIZE</b> =0: 512 bytes, SIZE=1: 1024 bytes
E610	1	EP1OUTCFG	Endpoint 1-OUT Configuration	VALID	0	TYPE1	TYPE0	0	0	0	0	10100000	rbbrrr	default: BULK OUT 64
E611	1	EP1INCFG	Endpoint 1-IN Configuration	VALID	0	TYPE1	TYPE0	0	0	0	0	10100000	rbbrrr	default: BULK OUT 64
E612	1	EP2CFG	Endpoint 2 Configuration	VALID	DIR	TYPE1	TYPE0	SIZE	0	BUF1	BUF0	10100010	bbbbrb	default: BULK OUT 512 double buffered
E613	1	EP4CFG	Endpoint 4 Configuration	VALID	DIR	TYPE1	TYPE0	0	0	0	0	10100000	bbbbrr	default: BULK OUT (512 double buffered only choice)
E614	1	EP6CFG	Endpoint 6 Configuration	VALID	DIR	TYPE1	TYPE0	SIZE	0	BUF1	BUF0	11100010	bbbbrb	default: BULK IN 512 double buffered
E615	1	EP8CFG	Endpoint 8 Configuration	VALID	DIR	TYPE1	TYPE0	0	0	0	0	11100000	bbbbrr	default: BULK IN (512 double buffered only choice)
	2	reserved												
E618	1	EP2FIFOCFG <i>see Section 15.14</i>	Endpoint 2 / slave FIFO configuration	0	INFM1	OEP1	AUTOOUT	AUTOIN	ZEROLENIN	0	WORDWIDE	00000101	rbbbrb	<b>INFM1</b> (In FULL flag minus 1): 0=normal, 1=flags active one byte early <b>OEP1</b> (Out EMPTY flag plus 1): 0=normal, 1=flags active one byte early <b>AUTOOUT</b> =1--valid OUT packet automatically becomes part of OUT FIFO <b>AUTOOUT</b> =0--8051 decides if to commit data to the OUT FIFO <b>AUTOIN</b> =1--SIE packetizes/dispatches IN-FIFO data using EPxAUTOINLEN <b>AUTOIN</b> =0--8051 dispatches an IN packet by writing byte count <b>WORDWIDE</b> =1: PB=FD[0:7], PD=FD[8:15]; =1: PB=FD[0:7], PD=PD <b>ZEROLENIN</b> : 0=disable; 1=send zero len pkt on PKTEND - If any of the four WORDWIDE bits=1, core configures PD as FD15:8
E619	1	EP4FIFOCFG <i>see Section 15.14</i>	Endpoint 4 / slave FIFO configuration	0	INFM1	OEP1	AUTOOUT	AUTOIN	ZEROLENIN	0	WORDWIDE	00000101	rbbbrb	
E61A	1	EP6FIFOCFG <i>see Section 15.14</i>	Endpoint 6 / slave FIFO configuration	0	INFM1	OEP1	AUTOOUT	AUTOIN	ZEROLENIN	0	WORDWIDE	00000101	rbbbrb	
E61B	1	EP8FIFOCFG <i>see Section 15.14</i>	Endpoint 8 / slave FIFO configuration	0	INFM1	OEP1	AUTOOUT	AUTOIN	ZEROLENIN	0	WORDWIDE	00000101	rbbbrb	
	4	reserved												



## EZ-USB FX2 Registers & Buffers

Hex	Size	Name	Description	b7	b6	b5	b4	b3	b2	b1	b0	Default	Access	Notes
E620	1	EP2AUTOINLENH <i>see Section 15.14</i>	Endpoint 2 AUTOIN Packet Length H	0	0	0	0	0	PL10	PL9	PL8	00000010	rrrrbbb	Default is 512 byte packets; can set smaller IN packets. SIE divides IN-FIFO data into this-length packets when AUTOIN=1. When AUTOIN=0, 8051 loads a byte count for every packet (in EPxBCH/L). EP2,6 can have 1024 max bytes. EP4,8 can have 512 max bytes. these registers only used for AUTOIN
E621	1	EP2AUTOINLENL <i>see Section 15.14</i>	Endpoint 2 AUTOIN Packet Length L	PL7	PL6	PL5	PL4	PL3	PL2	PL1	PL0	00000000	RW	
E622	1	EP4AUTOINLENH <i>see Section 15.14</i>	Endpoint 4 AUTOIN Packet Length H	0	0	0	0	0	0	PL9	PL8	00000010	rrrrbbb	
E623	1	EP4AUTOINLENL <i>see Section 15.14</i>	Endpoint 4 AUTOIN Packet Length L	PL7	PL6	PL5	PL4	PL3	PL2	PL1	PL0	00000000	RW	
E624	1	EP6AUTOINLENH <i>see Section 15.14</i>	Endpoint 6 AUTOIN Packet Length H	0	0	0	0	0	PL10	PL9	PL8	00000010	rrrrbbb	
E625	1	EP6AUTOINLENL <i>see Section 15.14</i>	Endpoint 6 AUTOIN Packet Length L	PL7	PL6	PL5	PL4	PL3	PL2	PL1	PL0	00000000	RW	
E626	1	EP8AUTOINLENH <i>see Section 15.14</i>	Endpoint 8 AUTOIN Packet Length H	0	0	0	0	0	0	PL9	PL8	00000010	rrrrbbb	
E627	1	EP8AUTOINLENL <i>see Section 15.14</i>	Endpoint 8 AUTOIN Packet Length L	PL7	PL6	PL5	PL4	PL3	PL2	PL1	PL0	00000000	RW	
	8	reserved												
E630	1	EP2FIFOPFH <i>see Section 15.14</i>	Endpoint 2 / slave FIFO Programmable Flag H	DECIS	PKTSTAT	IN:PKTS[2] OUT:PFC12	IN:PKTS[1] OUT:PFC11	IN:PKTS[0] OUT:PFC10	0	PFC9	PFC8	10001000	bbbbbrbb	<b>DECIS</b> : PF decision bit. 0: PF=1 when BC <= PF; 1: PF=1 when BC >= PF <b>PKTSTAT</b> =0--PF and BC refer to full FIFO; =1: PF/BC refer to current packet (IN) (OUT) PF/BC refer to full FIFO
E630	1	EP2FIFOPFH <i>see Section 15.14</i>	Endpoint 2 / slave FIFO Programmable Flag H	DECIS	PKTSTAT	OUT:PFC12	OUT:PFC11	OUT:PFC10	0	PFC9	IN:PKTS[2] OUT:PFC8	10001000	bbbbbrbb	
E631	1	EP2FIFOPFL <i>see Section 15.14</i>	Endpoint 2 / slave FIFO Programmable Flag L	PFC7	PFC6	PFC5	PFC4	PFC3	PFC2	PFC1	PFC0	00000000	RW	
E631	1	EP2FIFOPFL <i>see Section 15.14</i>	Endpoint 2 / slave FIFO Programmable Flag L	IN:PKTS[1] OUT:PFC7	IN:PKTS[0] OUT:PFC6	PFC5	PFC4	PFC3	PFC2	PFC1	PFC0	00000000	RW	
E632	1	EP4FIFOPFH <i>see Section 15.14</i>	Endpoint 4 / slave FIFO Programmable Flag H	DECIS	PKTSTAT	0	IN: PKTS[1] OUT:PFC10	IN: PKTS[0] OUT:PFC9	0	0	PFC8	10001000	bbrbrbrb	max 1024
E632	1	EP4FIFOPFH <i>see Section 15.14</i>	Endpoint 4 / slave FIFO Programmable Flag H	DECIS	PKTSTAT	0	OUT:PFC10	OUT:PFC9	0	0	PFC8	10001000	bbrbrbrb	max 1024
E633	1	EP4FIFOPFL <i>see Section 15.14</i>	Endpoint 4 / slave FIFO Programmable Flag L	PFC7	PFC6	PFC5	PFC4	PFC3	PFC2	PFC1	PFC0	00000000	RW	
E633	1	EP4FIFOPFL <i>see Section 15.14</i>	Endpoint 4 / slave FIFO Programmable Flag L	IN: PKTS[1] OUT:PFC7	IN: PKTS[0] OUT:PFC6	PFC5	PFC4	PFC3	PFC2	PFC1	PFC0	00000000	RW	
E634	1	EP6FIFOPFH <i>see Section 15.14</i>	Endpoint 6 / slave FIFO Programmable Flag H	DECIS	PKTSTAT	IN:PKTS[2] OUT:PFC12	IN:PKTS[1] OUT:PFC11	IN:PKTS[0] OUT:PFC10	0	PFC9	PFC8	00001000	bbbbbrbb	max 2048
E634	1	EP6FIFOPFH <i>see Section 15.14</i>	Endpoint 6 / slave FIFO Programmable Flag H	DECIS	PKTSTAT	OUT:PFC12	OUT:PFC11	OUT:PFC10	0	PFC9	IN:PKTS[2] OUT:PFC8	00001000	bbbbbrbb	max 2048
E635	1	EP6FIFOPFL <i>see Section 15.14</i>	Endpoint 6 / slave FIFO Programmable Flag L	PFC7	PFC6	PFC5	PFC4	PFC3	PFC2	PFC1	PFC0	00000000	RW	
E635	1	EP6FIFOPFL <i>see Section 15.14</i>	Endpoint 6 / slave FIFO Programmable Flag L	IN:PKTS[1] OUT:PFC7	IN:PKTS[0] OUT:PFC6	PFC5	PFC4	PFC3	PFC2	PFC1	PFC0	00000000	RW	
E636	1	EP8FIFOPFH <i>see Section 15.14</i>	Endpoint 8 / slave FIFO Programmable Flag H	DECIS	PKTSTAT	0	IN: PKTS[1] OUT:PFC10	IN: PKTS[0] OUT:PFC9	0	0	PFC8	00001000	bbrbrbrb	max 1024
E636	1	EP8FIFOPFH <i>see Section 15.14</i>	Endpoint 8 / slave FIFO Programmable Flag H	DECIS	PKTSTAT	0	OUT:PFC10	OUT:PFC9	0	0	PFC8	00001000	bbrbrbrb	max 1024
E637	1	EP8FIFOPFL <i>see Section 15.14</i>	Endpoint 8 / slave FIFO Programmable Flag L	PFC7	PFC6	PFC5	PFC4	PFC3	PFC2	PFC1	PFC0	00000000	RW	
E637	1	EP8FIFOPFL <i>see Section 15.14</i>	Endpoint 8 / slave FIFO Programmable Flag L	IN: PKTS[1] OUT:PFC7	IN: PKTS[0] OUT:PFC6	PFC5	PFC4	PFC3	PFC2	PFC1	PFC0	00000000	RW	
	8	reserved												



## EZ-USB FX2 Registers & Buffers

Hex	Size	Name	Description	b7	b6	b5	b4	b3	b2	b1	b0	Default	Access	Notes
E640	1	EP2ISOINPKTS	EP2 (if ISO) IN Packets per frame (1-3)	0	0	0	0	0	0	INPPF1	INPPF0	00000001	rrrrrb	INPPF1:0: 00=illegal, 01=1 per frame, 10=2 per frame, 11=3 per frame
E641	1	EP4ISOINPKTS	EP4 (if ISO) IN Packets per frame (1-3)	0	0	0	0	0	0	INPPF1	INPPF0	00000001	rrrrrb	
E642	1	EP6ISOINPKTS	EP6 (if ISO) IN Packets per frame (1-3)	0	0	0	0	0	0	INPPF1	INPPF0	00000001	rrrrrb	
E643	1	EP8ISOINPKTS	EP8 (if ISO) IN Packets per frame (1-3)	0	0	0	0	0	0	INPPF1	INPPF0	00000001	rrrrrb	
	4	reserved												
E648	1	INPKTEND <i>see Section 15.14</i>	Force IN Packet End	0	0	0	0	EP3	EP2	EP1	EP0	xxxxxxx	W	Same function as slave interface PKTEND pin, but 8051 controls dispatch of IN. Typically used after a GPIF FIFO transaction completes to send jagged edge pkt, user needs to check status of FIFO full flag for available buffer before doing PKTEND
E649	7	reserved												
		<b>INTERRUPTS</b>												
E650	1	EP2FIFOIE <i>see Section 15.14</i>	Endpoint 2 slave FIFO Flag Interrupt Enable	0	0	0	0	0	PF	EF	FF	00000000	RW	
E651	1	EP2FIFOIRQ <i>see Section 15.14</i>	Endpoint 2 slave FIFO Flag Interrupt Request	0	0	0	0	0	PF	EF	FF	00000xxx	RW	
E652	1	EP4FIFOIE <i>see Section 15.14</i>	Endpoint 4 slave FIFO Flag Interrupt Enable	0	0	0	0	0	PF	EF	FF	00000000	RW	
E653	1	EP4FIFOIRQ <i>see Section 15.14</i>	Endpoint 4 slave FIFO Flag Interrupt Request	0	0	0	0	0	PF	EF	FF	00000xxx	RW	
E654	1	EP6FIFOIE <i>see Section 15.14</i>	Endpoint 6 slave FIFO Flag Interrupt Enable	0	0	0	0	0	PF	EF	FF	00000000	RW	
E655	1	EP6FIFOIRQ <i>see Section 15.14</i>	Endpoint 6 slave FIFO Flag Interrupt Request	0	0	0	0	0	PF	EF	FF	00000xxx	RW	
E656	1	EP8FIFOIE <i>see Section 15.14</i>	Endpoint 8 slave FIFO Flag Interrupt Enable	0	0	0	0	0	PF	EF	FF	00000000	RW	
E657	1	EP8FIFOIRQ <i>see Section 15.14</i>	Endpoint 8 slave FIFO Flag Interrupt Request	0	0	0	0	0	PF	EF	FF	00000xxx	RW	
E658	1	IBNIE	IN-BULK-NAK Interrupt Enable	0	0	EP8	EP6	EP4	EP2	EP1	EP0	00000000	RW	
E659	1	IBNIRQ	IN-BULK-NAK interrupt Request	0	0	EP8	EP6	EP4	EP2	EP1	EP0	00xxxxxx	RW	1 = clear request, 0= no effect
E65A	1	NAKIE	Endpoint Ping-NAK / IBN Interrupt Enable	EP8	EP6	EP4	EP2	EP1	EP0	0	IBN	00000000	RW	OUT endpoint was pinged and NAK'd
E65B	1	NAKIRQ	Endpoint Ping-NAK / IBN Interrupt Request	EP8	EP6	EP4	EP2	EP1	EP0	0	IBN	xxxxxxx	RW	
E65C	1	USBIE	USB Int Enables	0	EP0ACK	HSGRANT	URES	SUSP	SUTOK	SOF	SUDAV	00000000	RW	
E65D	1	USBIRQ	USB Interrupt Requests	0	EP0ACK	HSGRANT	URES	SUSP	SUTOK	SOF	SUDAV	0xxxxxxx	RW	1 = clear request, 0= no effect
E65E	1	EPIE	Endpoint Interrupt Enables	EP8	EP6	EP4	EP2	EP1OUT	EP1IN	EP0OUT	EP0IN	00000000	RW	
E65F	1	EPIRQ	Endpoint Interrupt Requests	EP8	EP6	EP4	EP2	EP1OUT	EP1IN	EP0OUT	EP0IN	xxxxxxx	RW	1 = clear request, 0= no effect



## EZ-USB FX2 Registers & Buffers

Hex	Size	Name	Description	b7	b6	b5	b4	b3	b2	b1	b0	Default	Access	Notes
E660	1	GPIFIE <i>see Section 15.14</i>	GPIF Interrupt Enable	0	0	0	0	0	0	GPIFWF	GPIFDONE	00000000	RW	WF--8051 "hook" in waveform, DONE-returned to IDLE state
E661	1	GPIFIQ <i>see Section 15.14</i>	GPIF Interrupt Request	0	0	0	0	0	0	GPIFWF	GPIFDONE	000000xx	RW	Write "1" to clear
E662	1	USBERRIE	USB Error Interrupt Enables	ISOEP8	ISOEP6	ISOEP4	ISOEP2	0	0	0	ERRLIMIT	00000000	RW	ISO endpoint error: PID sequence error or dropped packet (no available buffer)
E663	1	USBERRIRQ	USB Error Interrupt Requests	ISOEP8	ISOEP6	ISOEP4	ISOEP2	0	0	0	ERRLIMIT	xxxx000x	RW	
E664	1	ERRCNTLIM	USB Error counter and limit	EC3	EC2	EC1	EC0	LIMIT3	LIMIT2	LIMIT1	LIMIT0	xxx0100	rrrrbbb	Default limit count is 4
E665	1	CLRERRCNT	Clear Error Counter EC3:0	x	x	x	x	x	x	x	x	xxxxxxx	W	
E666	1	INT2IVEC	Interrupt 2 (USB) Autovector	0	I2V4	I2V3	I2V2	I2V1	I2V0	0	0	00000000	R	
E667	1	INT4IVEC	Interrupt 4 (slave FIFO & GPIF) Autovector	1	0	I4V3	I4V2	I4V1	I4V0	0	0	10000000	R	
E668	1	INTSETUP	Interrupt 2&4 Setup	0	0	0	0	AV2EN	0	INT4SRC	AV4EN	00000000	RW	INT4IN=0: INT4 from pin; 1: INT4 from FIFO/GPIF interrupts
E669	7	reserved												
<b>INPUT / OUTPUT</b>														
E670	1	PORTACFG	I/O PORTA Alternate Configuration	FLAGD	SLCS	0	0	0	0	INT1	INT0	00000000	RW	
E671	1	PORTCCFG	I/O PORTC Alternate Configuration	GPIFA7	GPIFA6	GPIFA5	GPIFA4	GPIFA3	GPIFA2	GPIFA1	GPIFA0	00000000	RW	
E672	1	PORTECFG	I/O PORTE Alternate Configuration	GPIFA8	T2EX	INT6	RXD1OUT	RXD0OUT	T2OUT	T1OUT	T0OUT	00000000	RW	GSTATE bit =1 overrides bits 2:0.
E673	5	reserved												
E678	1	I2CS	I <sup>2</sup> C-Compatible Bus Control & Status	START	STOP	LASTRD	ID1	ID0	BERR	ACK	DONE	000xx000	bbrrrrr	
E679	1	I2DAT	I <sup>2</sup> C-Compatible Bus Data	d7	d6	d5	d4	d3	d2	d1	d0	xxxxxxx	RW	
E67A	1	I2CTL	I <sup>2</sup> C-Compatible Bus Control	0	0	0	0	0	0	STOPIE	400KHZ	00000000	RW	
E67B	1	XAUTODAT1	Autopr1 MOVX access, when EXTACC=1	D7	D6	D5	D4	D3	D2	D1	D0	xxxxxxx	RW	AUTOPTRESETUP bit
E67C	1	XAUTODAT2	Autopr2 MOVX access, when EXTACC=1	D7	D6	D5	D4	D3	D2	D1	D0	xxxxxxx	RW	EXTACC=1: off-chip access use this reg - code-space hole at this location AUTOPTRESETUP bit EXTACC=0: on-chip access use duplicate SFR @ 9C , no code-space hole
<b>UDMA CRC</b>														
E67D	1	UDMACRCH <i>see Section 15.14</i>	UDMA CRC MSB	CRC15	CRC14	CRC13	CRC12	CRC11	CRC10	CRC9	CRC8	01001010	RW	
E67E	1	UDMACRCL <i>see Section 15.14</i>	UDMA CRC LSB	CRC7	CRC6	CRC5	CRC4	CRC3	CRC2	CRC1	CRC0	10111010	RW	
E67F	1	UDMACRC-QUALIFIER	UDMA CRC Qualifier	QENABLE	0	0	0	QSTATE	QSIGNL2	QSIGNL1	QSIGNL0	00000000	brrrbbb	
<b>USB CONTROL</b>														
E680	1	USBCS	USB Control & Status	HSM	0	0	0	DISCON	NOSYNSOF	RENUM	SIGRSUME	x0000000	rrrrbbb	
E681	1	SUSPEND	Put chip into suspend	x	x	x	x	x	x	x	x	xxxxxxx	W	Write 0xFF to suspend



## EZ-USB FX2 Registers & Buffers

Hex	Size	Name	Description	b7	b6	b5	b4	b3	b2	b1	b0	Default	Access	Notes
E682	1	WAKEUPCS	WakeUp Control & Status	WU2	WU	WU2POL	WUPOL	0	DPEN	WU2EN	WUEN	xx000101	bbbbrb	
E683	1	TOGCTL	Toggle Control	Q	S	R	IO	EP3	EP2	EP1	EP0	xxxxxxxx	rb	
E684	1	USBFRAMEH	USB Frame count H	0	0	0	0	0	FC10	FC9	FC8	00000xxx	R	
E685	1	USBFRAMEL	USB Frame count L	FC7	FC6	FC5	FC4	FC3	FC2	FC1	FC0	xxxxxxxx	R	
E686	1	MICROFRAME	Microframe count, 0-7	0	0	0	0	0	MF2	MF1	MF0	00000xxx	R	
E687	1	FNADDR	USB Function address	0	FA6	FA5	FA4	FA3	FA2	FA1	FA0	0xxxxxxxx	R	
E688	2	reserved												
		<b>ENDPOINTS</b>												
E68A	1	EP0BCH	Endpoint 0 Byte Count H	(BC15)	(BC14)	(BC13)	(BC12)	(BC11)	(BC10)	(BC9)	(BC8)	xxxxxxxx	RW	Even though the EP0 buffer is only 64 bytes, the EP0 byte count is expanded to 16-bits to allow using the Autoptr with a custom length, instead of USB-dictated length (from Setup Data Packet and number of requested bytes). The byte count bits in parentheses apply only when SDPAUTO = 0
E68B	1	EP0BCL	Endpoint 0 Byte Count L	(BC7)	BC6	BC5	BC4	BC3	BC2	BC1	BC0	xxxxxxxx	RW	
E68C	1	reserved												
E68D	1	EP1OUTBC	Endpoint 1 OUT Byte Count	0	BC6	BC5	BC4	BC3	BC2	BC1	BC0	0xxxxxxxx	RW	
E68E	1	reserved												
E68F	1	EP1INBC	Endpoint 1 IN Byte Count	0	BC6	BC5	BC4	BC3	BC2	BC1	BC0	0xxxxxxxx	RW	
E690	1	EP2BCH <i>see Section 15.14</i>	Endpoint 2 Byte Count H	0	0	0	0	0	BC10	BC9	BC8	00000xxx	RW	EP2,6 can be 512 or 1024 EP4,8 are 512 only For IN endpoint, b7=BC7 For OUT endpoint, b7=SKIP, b6-b0=don't care. SKIP=0 means commit to FIFO, SKIP=1 means discard
E691	1	EP2BCL <i>see Section 15.14</i>	Endpoint 2 Byte Count L	BC7/SKIP	BC6	BC5	BC4	BC3	BC2	BC1	BC0	xxxxxxxx	RW	
E692	2	reserved												
E694	1	EP4BCH <i>see Section 15.14</i>	Endpoint 4 Byte Count H	0	0	0	0	0	0	BC9	BC8	000000xx	RW	
E695	1	EP4BCL <i>see Section 15.14</i>	Endpoint 4 Byte Count L	BC7/SKIP	BC6	BC5	BC4	BC3	BC2	BC1	BC0	xxxxxxxx	RW	
E696	2	reserved												
E698	1	EP6BCH <i>see Section 15.14</i>	Endpoint 6 Byte Count H	0	0	0	0	0	BC10	BC9	BC8	00000xxx	RW	
E699	1	EP6BCL <i>see Section 15.14</i>	Endpoint 6 Byte Count L	BC7/SKIP	BC6	BC5	BC4	BC3	BC2	BC1	BC0	xxxxxxxx	RW	
E69A	2	reserved												
E69C	1	EP8BCH <i>see Section 15.14</i>	Endpoint 8 Byte Count H	0	0	0	0	0	0	BC9	BC8	000000xx	RW	
E69D	1	EP8BCL <i>see Section 15.14</i>	Endpoint 8 Byte Count L	BC7/SKIP	BC6	BC5	BC4	BC3	BC2	BC1	BC0	xxxxxxxx	RW	
E69E	2	reserved												
E6A0	1	EP0CS	Endpoint 0 Control and Status	HSNAK	0	0	0	0	0	BUSY	STALL	10000000	bbbbbrb	
E6A1	1	EP1OUTCS	Endpoint 1 OUT Control and Status	0	0	0	0	0	0	BUSY	STALL	00000000	bbbbbrb	
E6A2	1	EP1INCS	Endpoint 1 IN Control and Status	0	0	0	0	0	0	BUSY	STALL	00000000	bbbbbrb	



## EZ-USB FX2 Registers & Buffers

Hex	Size	Name	Description	b7	b6	b5	b4	b3	b2	b1	b0	Default	Access	Notes
E6A3	1	EP2CS	Endpoint 2 Control and Status	0	NPAK2	NPAK1	NPAK0	FULL	EMPTY	0	STALL	00101000	rrrrrrb	NPAK2:0=number of packets in the FIFO, 0-4. NPAK1:0=number of packets in the FIFO, 0-2 OUT: Packets received from USB. IN: Packets loaded and armed. FULL / EMPTY status bits duplicated in SFR space, EP2468STAT
E6A4	1	EP4CS	Endpoint 4 Control and Status	0	0	NPAK1	NPAK0	FULL	EMPTY	0	STALL	00101000	rrrrrrb	
E6A5	1	EP6CS	Endpoint 6 Control and Status	0	NPAK2	NPAK1	NPAK0	FULL	EMPTY	0	STALL	00000100	rrrrrrb	
E6A6	1	EP8CS	Endpoint 8 Control and Status	0	0	NPAK1	NPAK0	FULL	EMPTY	0	STALL	00000100	rrrrrrb	
E6A7	1	EP2FIFOFLGS	Endpoint 2 slave FIFO Flags	0	0	0	0	0	PF	EF	FF	00000010	R	Not affected by FIFOPINPOLAR bits. duplicated in SFR space, EP24FIFOFLGS and EP68FIFOFLGS
E6A8	1	EP4FIFOFLGS	Endpoint 4 slave FIFO Flags	0	0	0	0	0	PF	EF	FF	00000010	R	
E6A9	1	EP6FIFOFLGS	Endpoint 6 slave FIFO Flags	0	0	0	0	0	PF	EF	FF	00000110	R	
E6AA	1	EP8FIFOFLGS	Endpoint 8 slave FIFO Flags	0	0	0	0	0	PF	EF	FF	00000110	R	
E6AB	1	EP2FIOBCH	Endpoint 2 slave FIFO total byte count H	0	0	0	BC12	BC11	BC10	BC9	BC8	00000000	R	OUT: full byte count; IN: bytes in current packet EP2 max 4096 EP6 max 1024 EP8 max 2048 EP4 max 1024
E6AC	1	EP2FIOBCL	Endpoint 2 slave FIFO total byte count L	BC7	BC6	BC5	BC4	BC3	BC2	BC1	BC0	00000000	R	
E6AD	1	EP4FIOBCH	Endpoint 4 slave FIFO total byte count H	0	0	0	0	0	BC10	BC9	BC8	00000000	R	
E6AE	1	EP4FIOBCL	Endpoint 4 slave FIFO total byte count L	BC7	BC6	BC5	BC4	BC3	BC2	BC1	BC0	00000000	R	
E6AF	1	EP6FIOBCH	Endpoint 6 slave FIFO total byte count H	0	0	0	0	BC11	BC10	BC9	BC8	00000000	R	
E6B0	1	EP6FIOBCL	Endpoint 6 slave FIFO total byte count L	BC7	BC6	BC5	BC4	BC3	BC2	BC1	BC0	00000000	R	
E6B1	1	EP8FIOBCH	Endpoint 8 slave FIFO total byte count H	0	0	0	0	0	BC10	BC9	BC8	00000000	R	
E6B2	1	EP8FIOBCL	Endpoint 8 slave FIFO total byte count L	BC7	BC6	BC5	BC4	BC3	BC2	BC1	BC0	00000000	R	
E6B3	1	SUDPTRH	Setup Data Pointer high address byte	A15	A14	A13	A12	A11	A10	A9	A8	xxxxxxx	RW	
E6B4	1	SUDPTRL	Setup Data Pointer low address byte	A7	A6	A5	A4	A3	A2	A1	0	xxxxxxx0	bbbbbbb	Must be word-aligned (i.e., must point to even-numbered addresses)
E6B5	1	SUDPTRCTL	Setup Data Pointer Auto Mode	0	0	0	0	0	0	0	SDPAUTO	00000001	RW	Clear b0 to supply SUDPTR length (override USB length)
	2	reserved												
E6B8	8	SETUPBUF	8 bytes of SETUP data	D7	D6	D5	D4	D3	D2	D1	D0	xxxxxxx	R	
			SETUPDAT[0] = bmRequestType											D7: Data Transfer Direction; 0=host-to-device, 1=device-to-host D6...5 Type; 0=standard, 1=class, 2=vendor, 3=reserved D4...0 Recipient; 0=device, 1=interface, 2=endpoint, 3=other, 4...31=reserved
			SETUPDAT[1] = bmRequest											specific request
			SETUPDAT[2:3] = wValue											word-sized field that varies according to request



## EZ-USB FX2 Registers & Buffers

Hex	Size	Name	Description	b7	b6	b5	b4	b3	b2	b1	b0	Default	Access	Notes
			SETUPDAT[4:5] = wIndex											word-sized field that varies according to request; typ. used to pass an index or offset
			SETUPDAT[6:7] = wLength											number of bytes to transfer if there is a data stage
		<b>GPIF</b>												
E6C0	1	GPIFWFSELECT	Waveform Selector	SINGLEWR1	SINGLEWR0	SINGLERD1	SINGLERD0	FIFOWR1	FIFOWR0	FIFORD1	FIFORD0	11100100	RW	Select waveform
E6C1	1	GPIFIDLECS	GPIF Done, GPIF IDLE drive mode	DONE	0	0	0	0	0	0	IDLEDRV	10000000	RW	DONE=1: GPIF done (IRQ4), IDLEDRV=1: drive bus, 0:TS DONE duplicated in SFR space, GPIFTRIG bit 7
E6C2	1	GPIFIDLECTL	Inactive Bus, CTL states	0	0	CTL5	CTL4	CTL3	CTL2	CTL1	CTL0	11111111	RW	
E6C3	1	GPIFCTLCFG	CTL Drive Type	TRICTL	0	CTL5	CTL4	CTL3	CTL2	CTL1	CTL0	00000000	RW	
E6C4	1	GPIFADRH <i>see Section 15.14</i>	GPIF Address H	0	0	0	0	0	0	0	GPIFA8	00000000	RW	GPIFADRH/L active immediately when written to
E6C5	1	GPIFADRL <i>see Section 15.14</i>	GPIF Address L	GPIFA7	GPIFA6	GPIFA5	GPIFA4	GPIFA3	GPIFA2	GPIFA1	GPIFA0	00000000	RW	
		<b>FLOWSTATE</b>												
E6C6	1	FLOWSTATE	Flowstate Enable and Selector	FSE	0	0	0	0	FS2	FS1	FS0	00000000	rrrrrbbb	
E6C7	1	FLOWLOGIC	Flowstate Logic	LFUNC1	LFUNC0	TERMA2	TERMA1	TERMA0	TERMB2	TERMB1	TERMB0	00000000	RW	
E6C8	1	FLOWEQ0CTL	CTL-Pin States in Flowstate (when Logic = 0)	CTL0E3	CTL0E2	CTL0E1/CTL5	CTL0E0/CTL4	CTL3	CTL2	CTL1	CTL0	00000000	RW	
E6C9	1	FLOWEQ1CTL	CTL-Pin States in Flowstate (when Logic = 1)	CTL0E3	CTL0E2	CTL0E1/CTL5	CTL0E0/CTL4	CTL3	CTL2	CTL1	CTL0	00000000	RW	
E6CA	1	FLOWHOLDOFF	Holdoff Configuration	HOPERIOD3	HOPERIOD2	HOPERIOD1	HOPERIOD0	HOSTATE	HOCTL2	HOCTL1	HOCTL0	00010010	RW	
E6CB	1	FLOWSTB	Flowstate Strobe Configuration	SLAVE	RDYASYN	CTLTOGL	SUSTAIN	0	MSTB2	MSTB1	MSTB0	00100000	RW	
E6CC	1	FLOWSTBEDGE	Flowstate Rising/Falling Edge Configuration	0	0	0	0	0	0	FALLING	RISING	00000001	rrrrrbbb	
E6CD	1	FLOWSTBPERIOD	Master-Strobe Half-Period	D7	D6	D5	D4	D3	D2	D1	D0	00000010	RW	In units of IFCLK/2. Must be >= 2
	2	reserved										00000000	RW	
E6D0	1	EP2GPIF1CH	Endpoint 2 GPIF Transaction Count High	TC15	TC14	TC13	TC12	TC11	TC10	TC9	TC8	00000000	RW	1 - 65535; 0 = 65536
E6D1	1	EP2GPIF1CL	Endpoint 2 GPIF Transaction Count Low	TC7	TC6	TC5	TC4	TC3	TC2	TC1	TC0	00000000	RW	
E6D2	1	EP2GPIFFLGSEL <i>see Section 15.14</i>	Endpoint 2 GPIF Flag select	0	0	0	0	0	0	FS1	FS0	00000000	RW	00: Programmable flag; 01: Empty, 10: Full, 11: reserved
E6D3	1	EP2GPIFFSTOP	Endpoint 2 GPIF stop transaction on prog. flag	0	0	0	0	0	0	0	FIFO2FLAG	00000000	RW	1=override TC value, stop on FIFO Prog. Flag.
E6D4	1	EP2GPIFTRIG <i>see Section 15.14</i>	Endpoint 2 GPIF Trigger	x	x	x	x	x	x	x	x	xxxxxxx	W	Start GPIF transactions, duplicated in SFR - GPIFTRIG
	3	reserved												
E6D8	1	EP4GPIF1CH	Endpoint 4 GPIF Transaction Count High	TC15	TC14	TC13	TC12	TC11	TC10	TC9	TC8	00000000	RW	
E6D9	1	EP4GPIF1CL	Endpoint 4 GPIF Transaction Count Low	TC7	TC6	TC5	TC4	TC3	TC2	TC1	TC0	00000000	RW	





## EZ-USB FX2 Registers & Buffers

Hex	Size	Name	Description	b7	b6	b5	b4	b3	b2	b1	b0	Default	Access	Notes
E6DA	1	EP4GPIFFLGSEL <i>see Section 15.14</i>	Endpoint 4 GPIF Flag select	0	0	0	0	0	0	FS1	FS0	00000000	RW	00: Programmable-Level; 01: Empty, 10: Full, 11: reserved
E6DB	1	EP4GPIFPFSTOP	Endpoint 4 GPIF stop transaction on GPIF Flag	0	0	0	0	0	0	0	FIFO4FLAG	00000000	RW	
E6DC	1	EP4GPIFTRIG <i>see Section 15.14</i>	Endpoint 4 GPIF Trigger	x	x	x	x	x	x	x	x	xxxxxxx	W	Start GPIF transactions, duplicated in SFR - GPIFTRIG
	3	reserved												
E6E0	1	EP6GPIF1CH	Endpoint 6 GPIF Transaction Count High	TC15	TC14	TC13	TC12	TC11	TC10	TC9	TC8	00000000	RW	
E6E1	1	EP6GPIF1CL	Endpoint 6 GPIF Transaction Count Low	TC7	TC6	TC5	TC4	TC3	TC2	TC1	TC0	00000000	RW	
E6E2	1	EP6GPIFFLGSEL <i>see Section 15.14</i>	Endpoint 6 GPIF Flag select	0	0	0	0	0	0	FS1	FS0	00000000	RW	00: Programmable flag; 01: Empty, 10: Full, 11: reserved (PF)
E6E3	1	EP6GPIFPFSTOP	Endpoint 6 GPIF stop transaction on prog. flag	0	0	0	0	0	0	0	FIFO6FLAG	00000000	RW	
E6E4	1	EP6GPIFTRIG <i>see Section 15.14</i>	Endpoint 6 GPIF Trigger	x	x	x	x	x	x	x	x	xxxxxxx	W	Start GPIF transactions, duplicated in SFR - GPIFTRIG
	3	reserved												
E6E8	1	EP8GPIF1CH	Endpoint 8 GPIF Transaction Count High	TC15	TC14	TC13	TC12	TC11	TC10	TC9	TC8	00000000	RW	
E6E9	1	EP8GPIF1CL	Endpoint 8 GPIF Transaction Count Low	TC7	TC6	TC5	TC4	TC3	TC2	TC1	TC0	00000000	RW	
E6EA	1	EP8GPIFFLGSEL <i>see Section 15.14</i>	Endpoint 8 GPIF Flag select	0	0	0	0	0	0	FS1	FS0	00000000	RW	00: Programmable flag; 01: Empty, 10: Full, 11: reserved (PF)
E6EB	1	EP8GPIFPFSTOP	Endpoint 8 GPIF stop transaction on prog. flag	0	0	0	0	0	0	0	FIFO8FLAG	00000000	RW	
E6EC	1	EP8GPIFTRIG <i>see Section 15.14</i>	Endpoint 8 GPIF Trigger	x	x	x	x	x	x	x	x	xxxxxxx	W	Start GPIF transactions, duplicated in SFR - GPIFTRIG
	3	reserved												
E6F0	1	XGPIFSGLDATH	GPIF Data H (16-bit mode only)	D15	D14	D13	D12	D11	D10	D9	D8	xxxxxxx	RW	duplicated in SFR space, SGLDATH / SGLDATHLX / SGLDATHLNOX
E6F1	1	XGPIFSGLDATHLX	Read/Write GPIF Data L & trigger transaction	D7	D6	D5	D4	D3	D2	D1	D0	xxxxxxx	RW	8051read or write triggers GPIF transaction
E6F2	1	XGPIFSGLDATHLNOX	Read GPIF Data L, no transaction trigger	D7	D6	D5	D4	D3	D2	D1	D0	xxxxxxx	R	8051 reads data w/o GPIF transaction trig. (e.g. last byte)
E6F3	1	GPIFREADYCFG	Internal RDY,Sync/Async, RDY pin states	INTRDY	SAS	TCXRDY5	0	0	0	0	0	00000000	bbrrrrr	<b>INTRDY</b> is 8051 'ready', like RDYn pins. RDYn indicate pin states  <b>SAS</b> =1: synchronous, 0:asynchronous (2-flops) RDYn inputs.
E6F4	1	GPIFREADYSTAT	GPIF Ready Status	0	0	RDY5	RDY4	RDY3	RDY2	RDY1	RDY0	00xxxxx	R	RDYn indicate pin states
E6F5	1	GPIFABORT	Abort GPIF Waveforms	x	x	x	x	x	x	x	x	xxxxxxx	W	Go To GPIF IDLE state. Data is don't care.
E6F6	2	reserved												
		<b>ENDPOINT BUFFERS</b>												



## EZ-USB FX2 Registers & Buffers

Hex	Size	Name	Description	b7	b6	b5	b4	b3	b2	b1	b0	Default	Access	Notes
E740	64	EP0BUF	EP0-IN-/OUT buffer	D7	D6	D5	D4	D3	D2	D1	D0	xxxxxxx	RW	
E780	64	EP10UTBUF	EP1-OUT buffer	D7	D6	D5	D4	D3	D2	D1	D0	xxxxxxx	RW	
E7C0	64	EP1INBUF	EP1-IN buffer	D7	D6	D5	D4	D3	D2	D1	D0	xxxxxxx	RW	
	2048	reserved											RW	
F000	1024	EP2FIFOBUF	512/1024-byte EP 2 / slave FIFO buffer (IN or OUT)	D7	D6	D5	D4	D3	D2	D1	D0	xxxxxxx	RW	For 512 use only 0xF000-0xF1FF
F400	512	EP4FIFOBUF	512 byte EP 4 / slave FIFO buffer (IN or OUT)	D7	D6	D5	D4	D3	D2	D1	D0	xxxxxxx	RW	
F600	512	reserved												
F800	1024	EP6FIFOBUF	512/1024-byte EP 6 / slave FIFO buffer (IN or OUT)	D7	D6	D5	D4	D3	D2	D1	D0	xxxxxxx	RW	For 512 use only 0xF800-0xF9FF
FC00	512	EP8FIFOBUF	512 byte EP 8 / slave FIFO buffer (IN or OUT)	D7	D6	D5	D4	D3	D2	D1	D0	xxxxxxx	RW	
FE00	512	reserved												
xxxx		<b>I<sup>2</sup>C Compatible Configuration Byte</b>		0	DISCON	0	0	0	0	0	400KHZ	xxxxxxx	n/a	
														<b>DISCON</b> =copied into DISCON bit (USBCS.3) for power-on USB connect state <b>400KHZ=1</b> for 400 KHz I <sup>2</sup> C compatible bus operation <b>NOTE:</b> if no EEPROM is connected all bits default to register default values.
<b>Special Function Registers (SFRs)</b>														
80	1	IOA <sup>(1)</sup>	Port A (bit addressable)	D7	D6	D5	D4	D3	D2	D1	D0	xxxxxxx	RW	
81	1	SP	Stack Pointer	D7	D6	D5	D4	D3	D2	D1	D0	0000111	RW	
82	1	DPL0	Data Pointer 0 L	A7	A6	A5	A4	A3	A2	A1	A0	0000000	RW	
83	1	DPH0	Data Pointer 0 H	A15	A14	A13	A12	A11	A10	A9	A8	0000000	RW	
84	1	DPL1 <sup>(1)</sup>	Data Pointer 1 L	A7	A6	A5	A4	A3	A2	A1	A0	0000000	RW	
85	1	DPH1 <sup>(1)</sup>	Data Pointer 1 H	A15	A14	A13	A12	A11	A10	A9	A8	0000000	RW	
86	1	DPS <sup>(1)</sup>	Data Pointer 0/1 select	0	0	0	0	0	0	0	SEL	0000000	RW	
87	1	PCON	Power Control	SMOD0	x	1	1	GF1	GF0	STOP	IDLE	00110000	RW	
88	1	TCON	Timer/Counter Control (bit addressable)	TF1	TR1	TF0	TR0	IE1	IT1	IE0	IT0	0000000	RW	
89	1	TMOD	Timer/Counter Mode Control	GATE	CT	M1	M0	GATE	CT	M1	M0	0000000	RW	
8A	1	TL0	Timer 0 reload L	D7	D6	D5	D4	D3	D2	D1	D0	0000000	RW	
8B	1	TL1	Timer 1 reload L	D7	D6	D5	D4	D3	D2	D1	D0	0000000	RW	
8C	1	TH0	Timer 0 reload H	D15	D14	D13	D12	D11	D10	D9	D8	0000000	RW	
8D	1	TH1	Timer 1 reload H	D15	D14	D13	D12	D11	D10	D9	D8	0000000	RW	
8E	1	CKCON <sup>(1)</sup>	Clock Control	x	x	T2M	T1M	T0M	MD2	MD1	MD0	0000001	RW	MOVX = 3 instr. cycles (default)
8F	1	reserved												
90	1	IOB <sup>(1)</sup>	Port B (bit addressable)	D7	D6	D5	D4	D3	D2	D1	D0	xxxxxxx	RW	
91	1	EXIF <sup>(1)</sup>	External Interrupt Flag(s)	IE5	IE4	I <sup>2</sup> CINT	USBNT	1	0	0	0	00001000	RW	



## EZ-USB FX2 Registers & Buffers

Hex	Size	Name	Description	b7	b6	b5	b4	b3	b2	b1	b0	Default	Access	Notes
92	1	MPAGE <sup>(1)</sup>	Upper Addr Byte of MOVX using @R0 / @R1	A15	A14	A13	A12	A11	A10	A9	A8	00000000	RW	used with the indirect addressing instruction(s), ie. MOVX @R0,A _where MPAGE = upper addr byte and R0 contains lower addr byte _an app. example would be to copy EP1 out/in data to a buffer
93	5	reserved												
98	1	SCON0	Serial Port 0 Control (bit addressable)	SM0_0	SM1_0	SM2_0	REN_0	TB8_0	RB8_0	TI_0	RI_0	00000000	RW	
99	1	SBUF0	Serial Port 0 Data Buffer	D7	D6	D5	D4	D3	D2	D1	D0	00000000	RW	
9A	1	AUTOPTRH1 <sup>(1)</sup>	Autopointer 1 Address H	A15	A14	A13	A12	A11	A10	A9	A8	00000000	RW	
9B	1	AUTOPTRL1 <sup>(1)</sup>	Autopointer 1 Address L	A7	A6	A5	A4	A3	A2	A1	A0	00000000	RW	
9C	1	AUTODAT1 <sup>(1)</sup>	Autodata 1	D7	D6	D5	D4	D3	D2	D1	D0	xxxxxxx	RW	used to access RAM location inside-chip (where core blocks RD/WR strobes)
9D	1	AUTOPTRH2 <sup>(1)</sup>	Autopointer 2 Address H	A15	A14	A13	A12	A11	A10	A9	A8	00000000	RW	
9E	1	AUTOPTRL2 <sup>(1)</sup>	Autopointer 2 Address L	A7	A6	A5	A4	A3	A2	A1	A0	00000000	RW	
9F	1	AUTODAT2 <sup>(1)</sup>	Autodata 2	D7	D6	D5	D4	D3	D2	D1	D0	xxxxxxx	RW	used to access RAM location inside-chip (where core blocks RD/WR strobes)
A0	1	IOC <sup>(1)</sup>	Port C (bit addressable)	D7	D6	D5	D4	D3	D2	D1	D0	xxxxxxx	RW	
A1	1	INT2CLR <sup>(1)</sup>	Interrupt 2 clear	x	x	x	x	x	x	x	x	xxxxxxx	W	
A2	1	INT4CLR <sup>(1)</sup>	Interrupt 4 clear	x	x	x	x	x	x	x	x	xxxxxxx	W	
A3	5	reserved												
A8	1	IE	Interrupt Enable (bit addressable)	EA	ES1	ET2	ES0	ET1	EX1	ET0	EX0	00000000	RW	
A9	1	reserved												
AA	1	EP2468STAT <sup>(1)</sup>	Endpoint 2,4,6,8 status flags	EP8F	EP8E	EP6F	EP6E	EP4F	EP4E	EP2F	EP2E	01011010	R	Check Empty/Full status of EP 2,4,6,8 using MOV
AB	1	EP24FIFOFLGS <sup>(1)</sup>	Endpoint 2,4 slave FIFO status flags	0	EP4PF	EP4EF	EP4FF	0	EP2PF	EP2EF	EP2FF	00100010	R	Check Prg/Empty/Full status of EP 2,4 slave FIFO using MOV instr.
AC	1	EP68FIFOFLGS <sup>(1)</sup>	Endpoint 6,8 slave FIFO status flags	0	EP8PF	EP8EF	EP8FF	0	EP6PF	EP6EF	EP6FF	01100110	R	Check Prg/Empty/Full status of EP 6,8 slave FIFO using MOV instr.
AD	2	reserved												
AF	1	AUTOPTRSETUP <sup>(1)</sup>	Autopointer 1&2 Setup	0	0	0	0	0	APTR2INC	APTR1INC	EXTACC	00000110	RW	APTRxINC=1 inc autopointer(s); APTRxINC=0 freeze autopointer(s) EXTACC=1 RD/WR strobes asserted when using MOVX version
B0	1	IOD <sup>(1)</sup>	Port D (bit addressable)	D7	D6	D5	D4	D3	D2	D1	D0	xxxxxxx	RW	
B1	1	IOE <sup>(1)</sup>	Port E (NOT bit addressable)	D7	D6	D5	D4	D3	D2	D1	D0	xxxxxxx	RW	
B2	1	OEA <sup>(1)</sup>	Port A Output Enable	D7	D6	D5	D4	D3	D2	D1	D0	00000000	RW	
B3	1	OEB <sup>(1)</sup>	Port B Output Enable	D7	D6	D5	D4	D3	D2	D1	D0	00000000	RW	
B4	1	OEC <sup>(1)</sup>	Port C Output Enable	D7	D6	D5	D4	D3	D2	D1	D0	00000000	RW	
B5	1	OED <sup>(1)</sup>	Port D Output Enable	D7	D6	D5	D4	D3	D2	D1	D0	00000000	RW	



## EZ-USB FX2 Registers & Buffers

Hex	Size	Name	Description	b7	b6	b5	b4	b3	b2	b1	b0	Default	Access	Notes
B6	1	OEE <sup>(1)</sup>	Port E Output Enable	D7	D6	D5	D4	D3	D2	D1	D0	00000000	RW	
B7	1	reserved												
B8	1	IP	Interrupt Priority (bit addressable)	1	PS1	PT2	PS0	PT1	PX1	PT0	PX0	10000000	RW	
B9	1	reserved												
BA	1	EP01STAT <sup>(1)</sup>	Endpoint 0&1 Status	0	0	0	0	0	EP1INBSY	EP1OUTBSY	EP0BSY	00000000	R	Check EP0 & EP1 status using MOV instr.
BB	1	GPIFTRIG <sup>(1)</sup> <i>see Section 15.14</i>	Endpoint 2,4,6,8 GPIF slave FIFO Trigger	DONE	0	0	0	0	RW	EP1	EP0	10000xxx	brrrrb	RW=1 reads, RW=0 writes; EP[1:0] = 00 EP2, = 01 EP4, = 10 EP6, = 11 EP8
BC	1	reserved												
BD	1	GPIFSGLDATH <sup>(1)</sup>	GPIF Data H (16-bit mode only)	D15	D14	D13	D12	D11	D10	D9	D8	xxxxxxx	RW	efficient version(s) of their MOVX buddies
BE	1	GPIFSGLDATLX <sup>(1)</sup>	GPIF Data L w/ Trigger	D7	D6	D5	D4	D3	D2	D1	D0	xxxxxxx	RW	
BF	1	GPIFSGLDATLNOX <sup>(1)</sup>	GPIF Data L w/ No Trigger	D7	D6	D5	D4	D3	D2	D1	D0	xxxxxxx	R	note READ only, this should help you decide when to appropriately use it
C0	1	SCON <sup>(1)</sup>	Serial Port 1 Control (bit addressable)	SM0_1	SM1_1	SM2_1	REN_1	TB8_1	RB8_1	TI_1	RI_1	00000000	RW	
C1	1	SBUF <sup>(1)</sup>	Serial Port 1 Data Buffer	D7	D6	D5	D4	D3	D2	D1	D0	00000000	RW	
C2	6	reserved												
C8	1	T2CON	Timer/Counter 2 Control (bit addressable)	TF2	EXF2	RCLK	TCLK	EXEN2	TR2	CT2	CPRL2	00000000	RW	
C9	1	reserved												
CA	1	RCAP2L	Capture for Timer 2, auto-reload, up-counter	D7	D6	D5	D4	D3	D2	D1	D0	00000000	RW	
CB	1	RCAP2H	Capture for Timer 2, auto-reload, up-counter	D7	D6	D5	D4	D3	D2	D1	D0	00000000	RW	
CC	1	TL2	Timer 2 reload L	D7	D6	D5	D4	D3	D2	D1	D0	00000000	RW	
CD	1	TH2	Timer 2 reload H	D15	D14	D13	D12	D11	D10	D9	D8	00000000	RW	
CE	2	reserved												
D0	1	PSW	Program Status Word (bit addressable)	CY	AC	F0	RS1	RS0	OV	F1	P	00000000	RW	
D1	7	reserved												
D8	1	EICON <sup>(1)</sup>	External Interrupt Control	SMOD1	1	ERESI	RESI	INT6	0	0	0	01000000	RW	RESI - reflects D+ / WU / WU2 src while SUSPEND (PCON.1), clocks off
D9	7	reserved												
E0	1	ACC	Accumulator (bit addressable)	D7	D6	D5	D4	D3	D2	D1	D0	00000000	RW	
E1	7	reserved												
E8	1	EIE <sup>(1)</sup>	External Interrupt Enable(s)	1	1	1	EX6	EX5	EX4	EI <sup>2</sup> C	EUSB	11100000	RW	
E9	7	reserved												
F0	1	B	B (bit addressable)	D7	D6	D5	D4	D3	D2	D1	D0	00000000	RW	
F1	7	reserved												
F8	1	EIP <sup>(1)</sup>	External Interrupt Priority Control	1	1	1	PX6	PX5	PX4	PI <sup>2</sup> C	PUSB	11100000	RW	
F9	7	reserved												



### EZ-USB FX2 Registers & Buffers

Hex	Size	Name	Description	b7	b6	b5	b4	b3	b2	b1	b0	Default	Access	Notes
(1) SFRs not part of the standard 8051 architecture.														

